

Trigonometric Identities

Physics 2

$$\sin^2 \theta + \cos^2 \theta = 1$$

$$\sin(A+B) = \sin A \cos B + \cos A \sin B$$

$$\cos(A+B) = \cos A \cos B - \sin A \sin B$$

$$\sin 2\theta = 2 \sin \theta \cos \theta$$

$$\cos 2\theta = \cos^2 \theta - \sin^2 \theta = 2 \cos^2 \theta - 1 = 1 - 2 \sin^2 \theta$$

$$\sin A + \sin B = 2 \sin \left(\frac{A+B}{2} \right) \cos \left(\frac{A-B}{2} \right)$$

$$\sin A - \sin B = 2 \sin \left(\frac{A-B}{2} \right) \cos \left(\frac{A+B}{2} \right)$$

$$\cos A + \cos B = 2 \cos \left(\frac{A+B}{2} \right) \cos \left(\frac{A-B}{2} \right)$$

$$\cos A - \cos B = -2 \sin \left(\frac{A+B}{2} \right) \sin \left(\frac{A-B}{2} \right)$$

$$\sin A \cos B = \frac{1}{2} \left[\sin(A+B) + \sin(A-B) \right]$$

$$\sin A \sin B = -\frac{1}{2} \left[\cos(A+B) - \cos(A-B) \right]$$

$$\cos A \cos B = \frac{1}{2} \left[\cos(A+B) + \cos(A-B) \right]$$

$$\cos A \sin B = \frac{1}{2} \left[\sin(A+B) - \sin(A-B) \right]$$

Topic	Chapter (Ghatak)	Lectures	Tut
Basics, Group-Phase Velocities, Oscillation Beats	7, 10, 11, 12 ✓ ✓ ✓ ✓	1, 2, 3, 4	7A 7B
Geometrical Optics	3, 4, 5, 6 ✓ ✓ ✓ ✓	5, 6	8
Interference	13, 14, 15, 16 ✓ ✓ ✓ ✓	7, 8, 9, 10	9
Diffraction, Resolving Power	18, 20 ✓ ✓	11, 12, 13, 14, 15	10, 11
Polarization	22 ✓	15, 16	12
Laser	26 ✓	17	13
Special Topics	17, 27, 21 ✓ ✓ ✓	10, 18	14

★ Wave Equation usually is " $A \sin(\omega t \pm kx)$ " i.e. ωt is always positive.

★ For a spherical wave, $I = \left(\frac{W}{4\pi r^2} \right) \Rightarrow a \propto \left(\frac{1}{r} \right)$

b : damping coefficient

c : damping ratio

where $\frac{b}{m} = 2c$

OPTICS (1)

- Huygen's Principle
- Equation
- Group velocity
- Dispersive Media

05/12/11

Various theories explaining the behaviour of light were prevalent:

330

1600 : Newton - Corpuscular Theory

then Huygen Wave Theory came

1765 : ~~Grimaldi~~ ^{Grimaldi} observed diffraction

1802 : Young observed superposition

1835 : Polarization was observed

} Can't be explained by Particle Theory

Fresnel resurrected Huygen's Wave Theory.

1864 : Maxwell's EM Wave Theory

1905, 1923 : Photoelectric Effect, Compton Effect observed

} Particle theory came up

If medium undergoes change, wave reflects

Huygen's Wave Theory

Source of wave sets up disturbance into the medium.

As a consequence of this, medium particles vibrate.

Locus of all particles vibrating with same phase constitute a wave front.

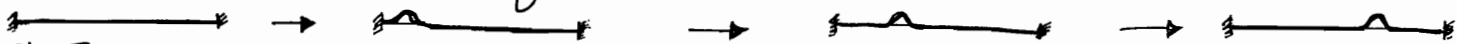
If I continuously do the plucking, it becomes a travelling wave.

We know

Wave Equation

$$y = a \sin(kx - \omega t + \phi_0)$$

initial phase at $t=0$
 $x=0$

1/2

Amplitude
or
 y_{max}

Phase ϕ

$$k = \frac{2\pi}{\lambda}$$

$$\omega = \frac{2\pi}{T}$$

- As defined, for wavefront phase = const.
 $\Rightarrow d(\phi) = 0$
 $\Rightarrow d(kx - \omega t + \phi_0) = 0$

For monochromatic wave, k and ω are constant

$$\Rightarrow k dx - \omega dt = 0$$

$$\Rightarrow \left(\frac{dx}{dt}\right) = v_p = \left[\frac{\omega}{k}\right]$$

$$= \frac{2\pi \nu}{\frac{2\pi}{\lambda}} = \lambda \nu = v$$

ie. { Phase Velocity = Wave Velocity } For Monochromatic wave only...
or wavefront velocity

- It is wavefront which carries energy and momentum. Velocity of wavefront is wave velocity and also phase velocity.

At $t=0$, wavefront position given at source

For point source, spherical wavefront

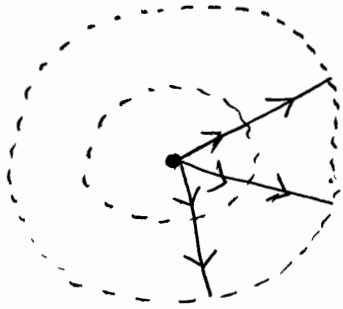

"light never travels backwards"

$$\left[\begin{array}{l} \text{Obliquity Factor} = 1 + \cos \theta \\ @ \theta = \pi, \text{ it is } 0 \end{array} \right]$$

For extended source, cylindrical wavefront

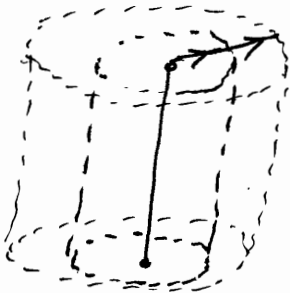

For distant source

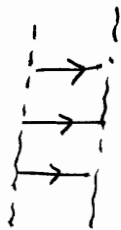

Flat Parallel wavefront
They are "Plane waves"

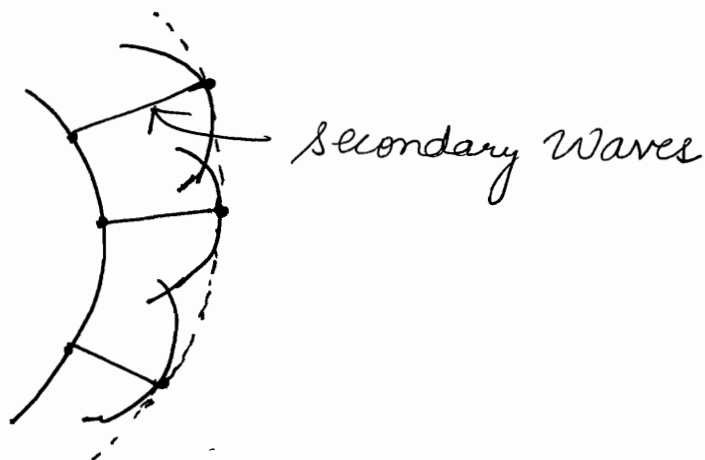

All points on wavefront are sources of secondary wavelets which travel with velocity v .
Hence at each point, draw arcs of length vt .
Envelopes of all arcs is the new wavefront.

Wave propagation is \perp to wavefront.

Reflection of Waves from Huygen's Principle

Waves can't pass through. Source is very far off, hence plane wave incident. AB: Plane wavefront.

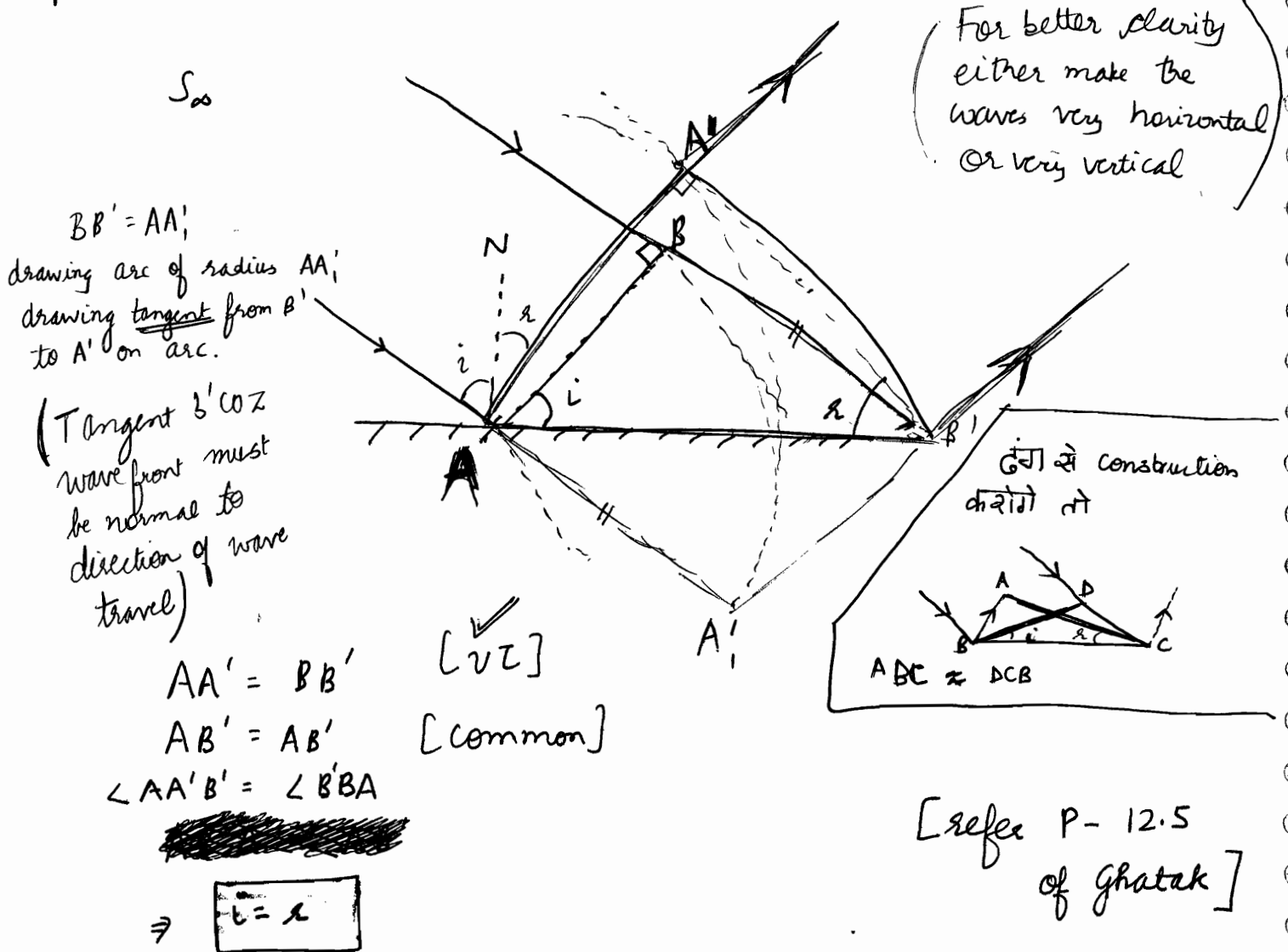

★ Angle measured from light rays to normal = Angle measured from wavefront to horizontal

$\rightarrow i = r$ because velocity = same in same medium
 $\Rightarrow \tau_1 = \tau_2$
 $\Rightarrow i = r$

Refraction of Waves

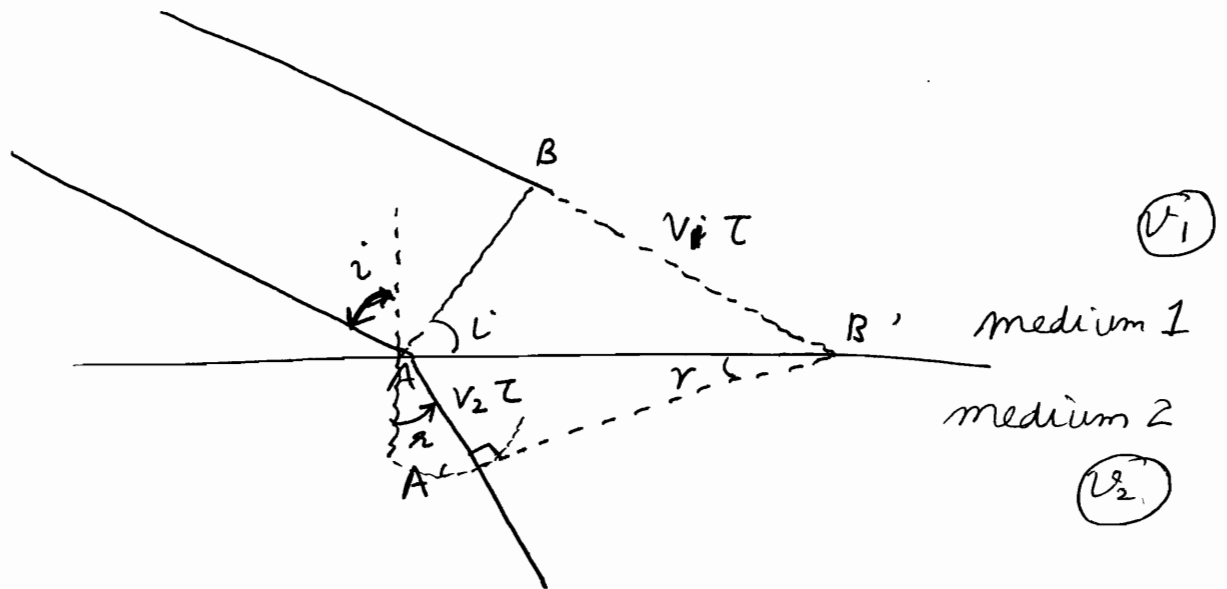

$$\frac{\sin i}{\sin r} = \left(\frac{v_1 t}{AB'} \right) / \left(\frac{v_2 t}{AB'} \right) = \left(\frac{v_1}{v_2} \right) = \left(\frac{n_2}{n_1} \right)$$

$$\Rightarrow \boxed{n_1 \sin i = n_2 \sin r}$$

Note that $n_1 v_1 = n_2 v_2 = c$

Huygen's Theory

① Wavefront is the locus of the points which are ^{vibrating} in the same phase. Huygen's Theory is essentially based on the geometrical construction which allows us to determine the shape of the wavefront at any time, if the shape of the wavefront at an earlier time is known.

② According to Huygen, each point of a wavefront is source of secondary wavelets. The envelope of these wavelets gives the shape of the new wavefront.

There is however one drawback with this model. It also gives rise to a backwave. To avoid this, later on obliquity factor $\left[\frac{1 + \cos \theta}{2} \right]$ was introduced.

Differential Equation of Monochromatic Wave

$$y = a \sin(kx - \omega t + \phi_0)$$

$$\left(\frac{\partial^2 y}{\partial x^2}\right) = \frac{k^2}{\omega^2} \left(\frac{\partial^2 y}{\partial t^2}\right) = \frac{1}{v_p^2} \left(\frac{\partial^2 y}{\partial t^2}\right)$$

→ Note that $\frac{\omega}{k} = v_p$

Such a wave is called Plane Progressive Wave

If ψ is the direction of displacement of medium particle,

$$\frac{\partial^2 \psi}{\partial x^2} + \frac{\partial^2 \psi}{\partial y^2} = \frac{1}{v^2} \left[\frac{\partial^2 \psi}{\partial t^2} \right] \quad \begin{array}{l} \text{2d wave} \\ \text{eg. Surface Wave} \end{array}$$

$$\frac{\partial^2 \psi}{\partial x^2} + \frac{\partial^2 \psi}{\partial y^2} + \frac{\partial^2 \psi}{\partial z^2} = \frac{1}{v^2} \left(\frac{\partial^2 \psi}{\partial t^2} \right) \quad \begin{array}{l} \text{3d wave} \\ \text{eg. Space Waves} \end{array}$$

$$\boxed{\nabla^2 \psi = \frac{1}{v^2} \left[\frac{\partial^2 \psi}{\partial t^2} \right]}$$

For a space wave, the solution of this equation is :

$$\psi(x, t) = \psi_0 e^{i(\vec{k} \cdot \vec{x} - \omega t + \phi)}$$

$$\psi(x, t) = \psi_0 \sin(\vec{k} \cdot \vec{x} - \omega t + \phi)$$

$$v_{\text{wave on string}} = \sqrt{\frac{T}{\rho}}$$

T: tension
ρ: mass per unit length

$$\text{solid} = \sqrt{\frac{Y}{\rho}}$$

Y: young's modulus
ρ: density

$$\text{gas} = \sqrt{\frac{\gamma P}{\rho}}$$

γ: Cp/Cv P: pressure ρ: density

$$\text{Wave Velocity or Phase Velocity} = \frac{d(\omega)}{dk}$$

Particle velocity = $\left(\frac{d\psi}{dt}\right)$ i.e. how particles vibrate

Group Velocity

velocity in a medium is same. λ will depend upon f of the source..... $\lambda = \left(\frac{v}{f}\right)$

In practice, no wave is monochromatic.

$$\Delta\lambda \approx 10^{-6} \text{ \AA} ; \text{ best possible lasers}$$

In practice we have pulses. Pulse is a superposition of monochromatic waves.

Velocity with which such a group of monochromatic waves ($\lambda_1, \lambda_2, \lambda_3, \dots, \lambda_n$) travel is called Group velocity.

$$v_g = \lim_{\Delta k \rightarrow 0} \left(\frac{\Delta\omega}{\Delta k}\right) = \left(\frac{d\omega}{dk}\right)$$

let us take 2 waves,

$$y_1 = a \sin(\omega_1 t - k_1 x)$$

$$y_2 = a \sin(\omega_2 t - k_2 x)$$

$$y = (y_1 + y_2) = 2a \sin \left[\left(\frac{\omega_1 + \omega_2}{2}\right)t - \left(\frac{k_1 + k_2}{2}\right)x \right] \cos \left[\left(\frac{\omega_1 - \omega_2}{2}\right)t - \left(\frac{k_1 - k_2}{2}\right)x \right]$$

$$= 2a \cos \left(\left[\left(\frac{\omega_1 - \omega_2}{2}\right)t \right] - \left[\frac{k_1 - k_2}{2} \right] x \right) \sin(\bar{\omega}t - \bar{k}x)$$

$$\text{where } \bar{\omega} = \frac{\omega_1 + \omega_2}{2} ; \bar{k} = \frac{k_1 + k_2}{2}$$

$$\Rightarrow y = \underbrace{A(x,t)}_{\text{Envelope}} \sin(\bar{\omega}t - \bar{k}x)$$

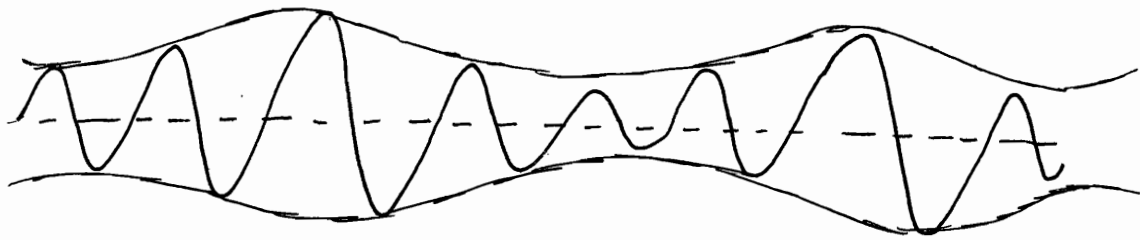

For case of 2 waves.....

$$v_g = \frac{\Delta\omega}{\Delta k} = \left[\frac{\omega_1 - \omega_2}{k_1 - k_2} \right]$$

$$v_g = \frac{d\omega}{dk} \quad : \quad \text{group velocity}$$

Equation of envelope
 $= 2a \cos \left[\left(\frac{\omega_1 - \omega_2}{2} \right) t + \left(\frac{k_1 - k_2}{2} \right) x \right]$
 This envelope is a wave of
 velocity $\frac{\omega'}{k'} = \left(\frac{\omega_1 - \omega_2}{k_1 - k_2} \right) = \left(\frac{\Delta\omega}{\Delta k} \right)$
 $= v_g$

Note that λ is not const. i.e. k is not const.

Let us consider a group of waves around ω . Let v_p be velocity for wave vibrating at frequency ω .

$$v_p = \frac{\omega}{k} = \lambda v$$

$$v_g = \frac{d\omega}{dk} = \frac{d}{dk} (k v_p) = v_p + \left(\frac{d v_p}{dk} \right) k$$

We know, $\lambda = \frac{2\pi}{k}$

$$\Rightarrow \frac{d\lambda}{dk} = -\frac{2\pi}{k^2}$$

$$v_g = v_p + k \left(\frac{d v_p}{d\lambda} \right) \cdot \left(\frac{d\lambda}{dk} \right)$$

$$\Rightarrow v_g = v_p + k \left(\frac{d v_p}{d\lambda} \right) \cdot -\frac{2\pi}{k^2}$$

$$\Rightarrow \boxed{v_g = v_p - \lambda \frac{d v_p}{d\lambda}}$$

If v_p is dependent upon λ , then medium is dispersive

$$\frac{dv_p}{d\lambda} \neq 0 \Rightarrow \text{dispersion}$$

होगा तो envelope की...
की velocity of envelope
= velocity of wave



If v_p is independent of λ , i.e. $\frac{dv_p}{d\lambda} = 0 \Rightarrow$

NO DISPERSION
 $\Rightarrow v_g = v_p$

Normal dispersion

$$\frac{dv_p}{d\lambda} > 0$$

i.e. $[v_{\text{red}}] > [v_{\text{blue}}]$

remember

$$v_p = \left(\frac{c}{n} \right)$$

n : refractive index

i.e. $v_p \propto \left(\frac{1}{n} \right)$

$$\Rightarrow (dv_p) \propto -(dn)$$

Hence for normal dispersion,

$$\frac{dn}{d\lambda} < 0$$

Also $\lambda \propto \frac{1}{\omega}$

i.e. $(d\lambda) \propto -(d\omega)$

Hence

$$\frac{dn}{d\omega} > 0$$

Now $v_g = v_p - \lambda \frac{dv_p}{d\lambda}$

\Rightarrow

$$v_g < v_p$$

Normal dispersion

Anomalous dispersion

$$\boxed{\left(\frac{dv_p}{d\lambda}\right) < 0} \quad \text{or} \quad \left(\frac{dn}{d\lambda}\right) > 0 \quad \text{or} \quad \left(\frac{dn}{d\omega}\right) < 0$$

ie. $v_{\text{red}} < v_{\text{blue}}$

Anomalous dispersion occurs over narrow frequency bands.

$$\boxed{v_g > v_p} \quad \text{Anomalous dispersion}$$

We know,

$$v_g = v_p - \lambda \frac{dv_p}{d\lambda}$$

We also know, $v_p = \left(\frac{c}{n}\right)$

$$\Rightarrow \frac{dv_p}{d\lambda} = \frac{dv_p}{dn} \cdot \left(\frac{dn}{d\lambda}\right) = -\frac{c}{n^2} \left(\frac{dn}{d\lambda}\right)$$

$$\Rightarrow v_g = v_p + \lambda \frac{c}{n^2} \left(\frac{dn}{d\lambda}\right)$$

$$\boxed{v_g = v_p \left[1 + \frac{\lambda}{n} \left(\frac{dn}{d\lambda}\right)\right]}$$

λ (A)	n
4000	1.52
4500	1.50
5000	1.47

$\frac{dn}{d\lambda}$ = Take avg. or extremes

Q1

$$v_p = \sqrt{\frac{g}{k}}$$

g : gravity

k : Propagation const.

$$v_g = v_p + \lambda \left(\frac{dv_p}{d\lambda} \right)$$

$\lambda = \frac{2\pi}{k}$ $k = \left(\frac{2\pi}{\lambda} \right)$	$\Rightarrow \frac{dv_p}{d\lambda} = \left(\frac{dv_p}{dk} \right) \left(\frac{dk}{d\lambda} \right) = -\frac{2\pi}{\lambda^2} \cdot \left(\frac{dv_p}{dk} \right)$
---	--

$$v_g = v_p + k \left(\frac{dv_p}{dk} \right)$$

$$\begin{aligned} \text{Now } \frac{dv_p}{dk} &= \frac{1}{2} \left(\frac{g}{k} \right)^{-\frac{1}{2}} \cdot \frac{-g}{k^2} = -\frac{1}{2} \frac{\frac{1}{k}}{\sqrt{g}} \frac{g}{k^2} \\ &= -\frac{1}{2} \frac{\sqrt{g}}{k \sqrt{k}} = \underline{\underline{-\frac{1}{2k} v_p}} \end{aligned}$$

$$\Rightarrow \underline{v_g} = v_p \left[1 + k \cdot \frac{-1}{2k} \right] = \underline{v_p} \left(\frac{v_p}{2} \right) \checkmark$$

For 20 marks, write v_g , v_p definitions
Write connections.

⊛ For $\theta < 4^\circ$, $\sin \theta \approx \theta$
 $\tan \theta \approx \theta$
 $\cos \theta \approx 1$

⊛ Rayleigh scattering is responsible for blue colour of the sky

$$I = I_0 e^{-r x} \quad (\text{due to scattering})$$

$$r \propto \frac{1}{\lambda^4}$$

For blue r is maximum ($\because \lambda$ is minimum)

\Rightarrow maximum scattering of blue component

\Rightarrow sky appears blue.

Similarly, blue component of the light coming from setting sun is predominantly scattered out resulting in the red colour of the setting sun.

Indeed, if the colour of the setting or rising sun is deep red, one can infer that the pollution level is high.

⊛ Similar to refractive index $n = \left(\frac{c}{v_p}\right)$, we have group index $n_g = \left(\frac{c}{v_g}\right)$

⊛ Reflection of light from smooth surface: SPECULAR REFLECTION
 irregular surface: DIFFUSE REFLECTION

⊛ Huygen's Principle along with the fact that the secondary wavelets mutually interfere, is known as the Huygens-Fresnel Principle. Note that in Huygen's Principle, we can't use the term "interference" as interference in light came much after that.

OPTICS (2)

0 SHM
0 Damped Oscillation
0 Forced Oscillation
06/12/11

Simple Harmonic Motion

For 1-d case,

$$(\vec{F}_{\text{restoring}}) \propto (-\vec{x})$$

$$\vec{F}_{\text{rest.}} = -k\vec{x}$$

$$U = - \int F \cdot dx = \frac{1}{2} kx^2$$

If Medium resistance is neglected \Rightarrow U+T remains conserved.

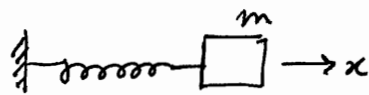

$$E = T + U = \frac{1}{2} mv^2 + \frac{1}{2} kx^2 = \text{const.}$$

\Rightarrow Amplitude will not decay.

$$m\ddot{x} = -kx \quad \dots \dots \text{ideal SHM}$$

$$\ddot{x} + \left(\frac{k}{m}\right)x = 0$$

$$\text{let } \sqrt{\frac{k}{m}} = \omega_0$$

$$\Rightarrow \ddot{x} + \omega_0^2 x = 0$$

$$\Rightarrow \ddot{x} = -\omega_0^2 x$$

Solution for this equation :

The solution of a differential equation consists of two parts: Homogenous & Particular solution. A differential equation is said to be homogenous, if there is no isolated constant term (not a function of x , may be function of t) in equation. The homogenous solution of the equation gives a zero value, hence can always be added to the particular solution as it will add only zero to the net result (the constant).

Arbitrary coefficients attached to the homogenous & particular solutions are determined by boundary conditions.

$$\ddot{x} + \omega_0^2 x = 0$$

$$\text{Solutions: } x = c_1 \sin \omega_0 t + c_2 \cos \omega_0 t$$

$$x = c_3 e^{i(\omega_0 t + \phi)}$$

$$x = c_4^* \sin(\omega_0 t + \phi)$$

⊛ These are 3 forms of possible solutions. We usually take the 3rd one.

Values of variables need to be determined from boundary conditions.

$$\text{Standard solution: } x = C \sin(\omega_0 t + \phi_0)$$

$$\text{Phase: } (\omega_0 t + \phi_0)$$

$$\text{Amplitude} = x_{\max} = C = A \text{ (say)}$$

$$\text{initial phase: } \omega_0 \cdot 0 + \phi_0 = \phi_0$$

$$x = A \sin(\omega_0 t + \phi_0)$$

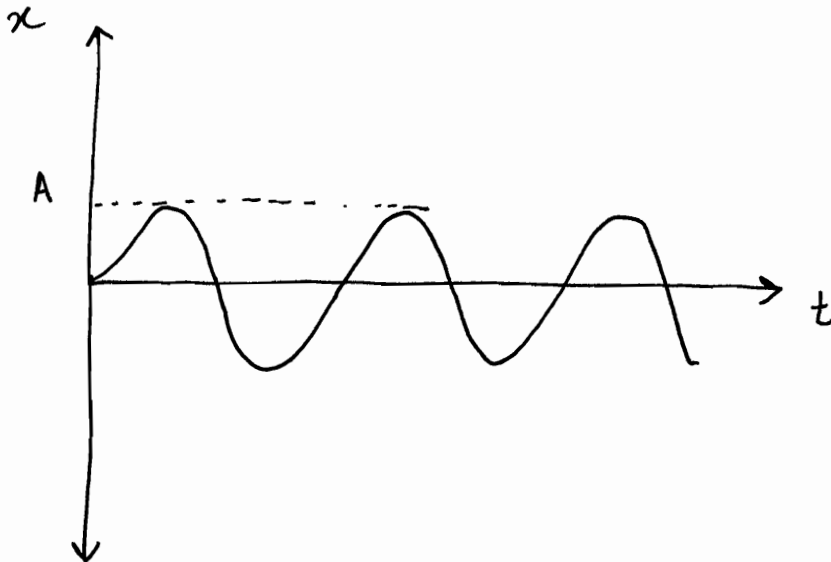

$$\dot{x} = A \omega_0 \cos(\omega_0 t + \phi_0)$$

$$E(t) = \frac{1}{2} m \dot{x}^2 + \frac{1}{2} k x^2$$

$$= \frac{1}{2} m A^2 \omega_0^2 \cos^2(\omega_0 t + \phi_0) + \frac{1}{2} k A^2 \sin^2(\omega_0 t + \phi_0)$$

$$= \frac{A^2 k}{2} (\cos^2(\omega_0 t + \phi_0) + \sin^2(\omega_0 t + \phi_0))$$

$$= \frac{1}{2} k A^2$$

~~~~~

$$= \text{const.}$$

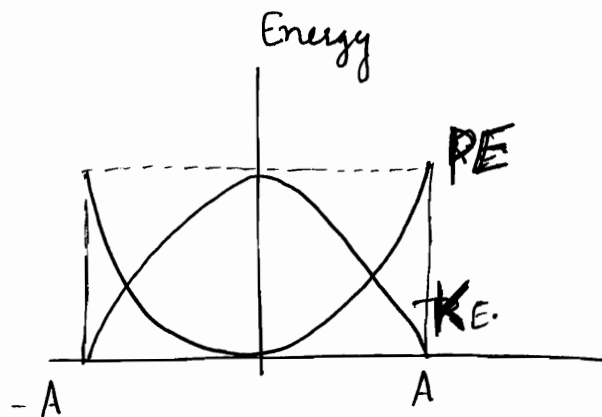

$$E(x) = \frac{1}{2} k a^2 \cos^2(\omega_0 t + \phi_0) + \frac{1}{2} k A^2 \sin^2(\omega_0 t + \phi_0)$$

$$= \frac{1}{2} k A^2 \left[ 1 - \frac{x^2}{A^2} \right] + \frac{1}{2} k A^2 \left[ \frac{x^2}{A^2} \right]$$

$$= \underbrace{\frac{1}{2} k [A^2 - x^2]}_{k \cdot E} + \underbrace{\frac{1}{2} k x^2}_{P \cdot E} = \frac{1}{2} k A^2$$

## Time Avg. of k.E. & P.E.

$$\left(\frac{1}{2}\right) = \left(\frac{1}{4}\right) + \left(\frac{1}{4}\right)$$

(K)                      (P)

$$\langle \cos^2 \theta \rangle = \frac{1}{2}$$

$$\langle \sin^2 \theta \rangle = \frac{1}{2}$$

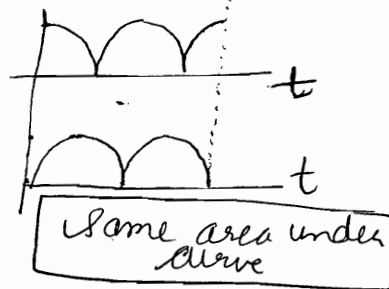

$\langle \rangle$  : Time Average

$$\int f(t) \cdot dt$$

$$\langle \cos^2 \theta \rangle = \frac{1}{2\pi} \int_0^{2\pi} \cos^2 \theta \, d\theta = \frac{1}{2\pi} \int_0^{2\pi} \frac{1 + \cos 2\theta}{2} \cdot d\theta = \left(\frac{1}{2}\right)$$

$$\langle \sin^2 \theta \rangle = \langle 1 - \cos^2 \theta \rangle = 1 - \langle \cos^2 \theta \rangle = 1 - \frac{1}{2} = \left(\frac{1}{2}\right)$$

$$\langle T \rangle = \frac{1}{4} k A^2$$

$$\langle U \rangle = \frac{1}{4} k A^2$$

$$\star \langle T \rangle = \langle U \rangle$$

## Space Avg. of k.E. & P.E.

$$\left(\frac{1}{2}\right) = \left(\frac{1}{3}\right) + \left(\frac{1}{6}\right)$$

(K)                      (P)

$$U = \frac{1}{2} k x^2$$

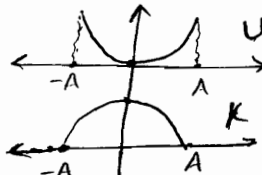

Area under k is more

$$\bar{U} = \frac{1}{2a} \int_{-a}^a \frac{1}{2} k x^2 \, dx$$

$$\bar{U} = \frac{k}{4a} \frac{1}{3} [2a^3] = \frac{1}{6} k a^2$$

$\bar{\lambda}$  : space average

Had it been the Energy Curves linear  $\bar{U}$  would have been equal to  $\bar{K}$  or  $\bar{T}$ .



But now the curves are Parabolic, area under curve of T is more  $\Rightarrow \bar{T} > \bar{U}$

Also both are equal & cross at  $0.7A$  not  $\left(\frac{A}{2}\right)$ . Hence  $kE > PE$  for major part.

$$\bar{T} = \frac{1}{2a} \int_{-a}^a \frac{1}{2} k A^2 \left[ 1 - \frac{x^2}{A^2} \right] \, dx$$

$$\bar{T} = \frac{k A^2}{4a} \left[ 2a - \frac{2A^3}{3A^2} \right] = \frac{k A^2}{4a} \left[ \frac{4A}{3} \right] = \frac{1}{3} k A^2$$

$$\bar{T} = 2 \bar{U}$$

✓ All pendulums are approximated to SHM

✓ Oscillation of LC circuit : SHM

✓ Vibrations of U-Tube water : SHM

Practically,  $A$  reduces with time since energy reduces with time due to non-conservative forces.

$$\vec{F}_{\text{non conservative}} = -b\vec{x}$$

If I take damping forces into account, we will call it Free Oscillation or damped Oscillation

### Damped Oscillations

For simplicity, we will consider 1-d motion i.e. linear harmonic oscillator.

[In 3-d motion, isotropic oscillators]  
 $k_{xx}, k_{yy}, k_{zz}$  are considered.

$$\vec{F}_{\text{net}} = \vec{F}_{\text{restoring}} + \vec{F}_{\text{damping}} = m\vec{a}$$

$$\Rightarrow m\ddot{x} = -kx - b\dot{x}$$

$$F_{\text{medium}} = -b\dot{x}$$

$$m\ddot{x} + b\dot{x} + kx = 0$$

$$\ddot{x} + \left(\frac{b}{m}\right)\dot{x} + \left(\frac{k}{m}\right)x = 0$$

Let  $\left(\frac{b}{m}\right) = 2c$  : damping const.

$\left(\frac{k}{m}\right) = \omega_0^2$  :  $\omega_0$  is undamped frequency

Note that  $c$  has dimensions of frequency

★

$$\ddot{x} + 2c\dot{x} + \omega_0^2 x = 0$$

How to solve:

guess, solution is  $Ae^{\alpha t}$

$$\dot{x} = A\alpha e^{\alpha t}$$

$$\ddot{x} = A\alpha^2 e^{\alpha t}$$

⇒ substituting

$$(A\alpha^2 + 2c\alpha A + \omega_0^2 A) e^{\alpha t} = 0$$

$$\Rightarrow \alpha^2 + 2c\alpha + \omega_0^2 = 0$$

$$\alpha = \frac{-2c \pm \sqrt{4c^2 - 4\omega_0^2}}{2}$$

$$\alpha = -c \pm \sqrt{c^2 - \omega_0^2}$$

Now 3 cases can occur

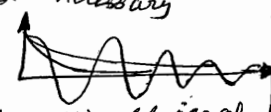
⊗ Note that the 3 solutions described below are in most general form and not necessarily shaped like  they can take all possible forms via choice of appropriate constants.

①

Damping Force > Natural Frequency

$$c > \omega_0 \Rightarrow$$

2 distinct roots

$$x = e^{-ct} [ A_1 e^{\sqrt{c^2 - \omega_0^2} t} + A_2 e^{-\sqrt{c^2 - \omega_0^2} t} ]$$

⇒ Over damped Case

Also called DEADBEAT MOTION

⊗ Aperiodic : We cannot write in form of Periodic Functions as Amplitude is decaying

Used in deadbeat galvanometer : When charge passes through coil, it is set into SHM with damping. For needle to come to rest immediately, damping is kept very high. No "i" in exponent

②  $C = \omega_0$  Critical Damping

1 root is :  $Ae^{-ct}$

2<sup>nd</sup> root : ?

let other solution be  $x_2 = f(t) e^{-ct}$

Solve for  $f(t)$

It turns out to be  $f(t) = t$  i.e.

$$x_2 = te^{-ct}$$

$$\Rightarrow x = e^{-ct} [A + Bt]$$

dying out vibrations

③  $C < \omega_0$  Underdamped Case

$$x = e^{-ct} \left[ A_1 e^{i\sqrt{\omega_0^2 - c^2} t} + A_2 e^{-i\sqrt{\omega_0^2 - c^2} t} \right]$$

Complex or Trigonometric solution

We can also write  $\omega_d = \sqrt{\omega_0^2 - c^2}$

$$\Rightarrow x = e^{-ct} \left[ A_1 \cos \omega_d t + i A_1 \sin \omega_d t + A_2 \cos \omega_d t - i A_2 \sin \omega_d t \right]$$

$$= e^{-ct} \left[ (A_1 + A_2) \cos \omega_d t + (A_1 - A_2) i \sin \omega_d t \right]$$

$A_1 = A_2$

$$= e^{-ct} \left[ 2A_1 \cos \omega_d t + i C_2 \sin \omega_d t \right]$$

$$= e^{-ct} a \sin [\omega_d t + \phi_0] \dots \dots \text{general}$$

$$x = a e^{-ct} [\sin (\omega_d t + \phi_0)]$$

decaying periodic motion

[ happens when underdamped i.e.  
damping force is small ]

$$\omega_d = \sqrt{\omega_0^2 - c^2}$$

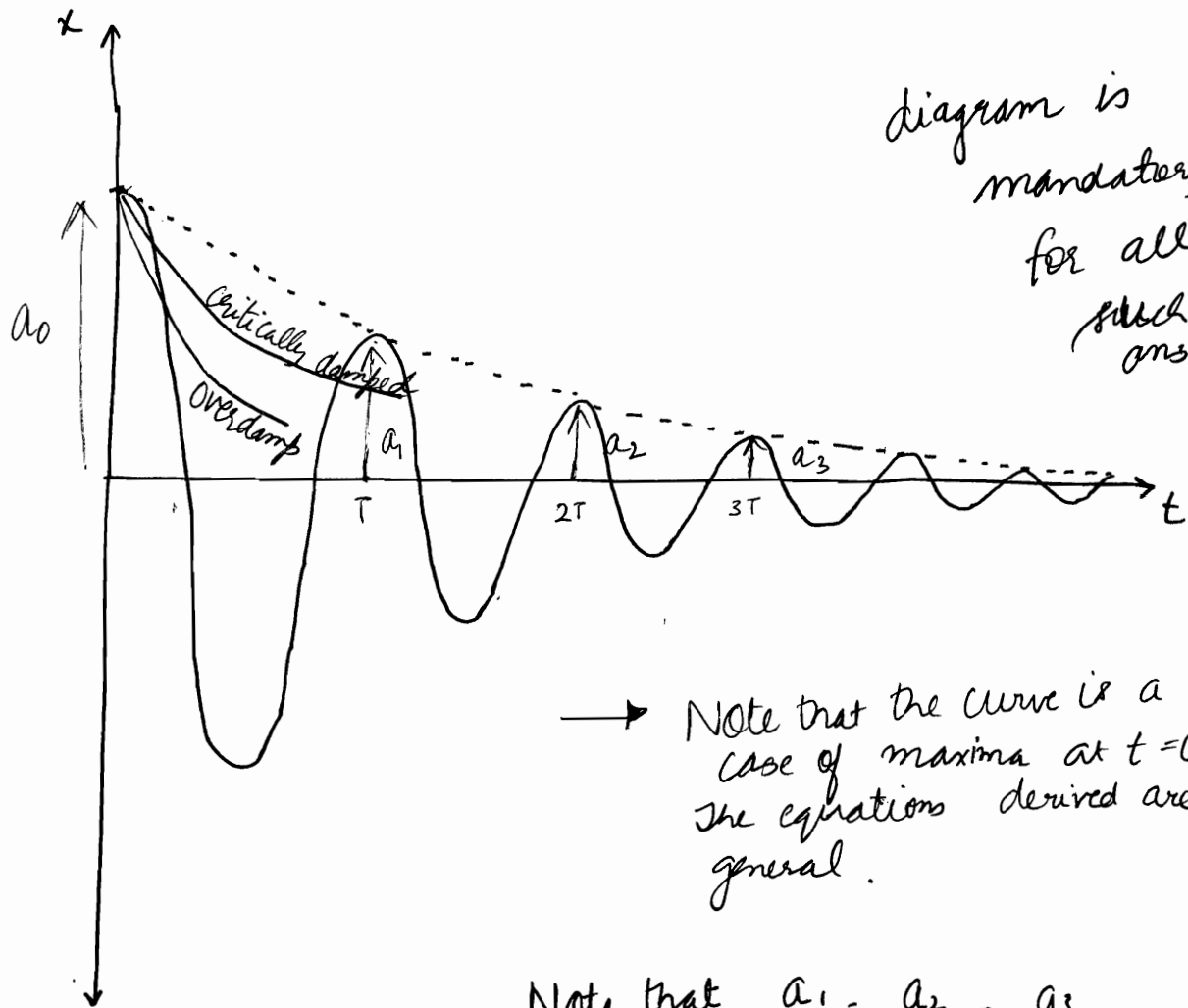

diagram is mandatory for all such answers...

→ Note that the curve is a special case of maxima at  $t=0$ . The equations derived are in general.

Note that  $\frac{a_1}{a_0} = \frac{a_2}{a_1} = \frac{a_3}{a_2} = \dots = \left( \frac{a_{n+1}}{a_n} \right)$

⊙ Its called logarithmic decrease

$$= e^{-cT}$$

$$\ln \left( \frac{a_{n+1}}{a_n} \right) = -cT$$

For Underdamped Case :-

$$E = \frac{1}{2} k x^2 + \frac{1}{2} m v^2$$

Energy Stored

Note that  $c < \omega_0$

$$c^2 \ll \omega_0^2$$

$$\omega_d = \sqrt{\omega_0^2 - c^2}$$

$$\Rightarrow \omega_d \approx \omega_0$$

Approximation (1)



Approximation (2)

$$E = \frac{1}{2} k a^2 e^{-2ct} \sin^2(\omega t + \phi)$$

$$+ \left[ \frac{1}{2} m a^2 \omega^2 e^{-2ct} \cos^2(\omega t + \phi) \right]$$

$$= \frac{1}{2} k a^2 e^{-2ct} \sin^2(\omega t + \phi) + \frac{1}{2} m a^2 \omega^2 e^{-2ct} \cos^2(\omega t + \phi)$$

$$+ \frac{2c m a^2 \omega^2 e^{-2ct} \sin(\omega t + \phi) \cos(\omega t + \phi)}{\sin(\omega t + \phi)}$$

[neglected]

$$= \frac{1}{2} k a^2 e^{-2ct} [\sin^2(\omega t + \phi) + \cos^2(\omega t + \phi)]$$

$$E(t) = \frac{1}{2} k a^2 e^{-2ct}$$

$$\Rightarrow E = E_{\max} e^{-2ct}$$

Note that Energy drop rate is twice of amplitude drop rate.

$$E_{\max} = \frac{1}{2} k a^2$$

Remember

$$\frac{b}{m} = 2c = \text{damp. Const}$$

$$\text{Energy dissipation} = \frac{dE}{dt}$$

$$= -2cE$$

Dimensionless quantity

$$\text{Quality Factor } (Q) = 2\pi \left[ \frac{\text{Energy stored in system}}{\text{Energy lost per cycle}} \right]_{\omega = \omega_r}$$

As energy is continuously decreasing, there is actually no point of resonance.

$$= 2\pi \frac{E}{2cE \cdot (T)}$$

$$Q = \left[ \frac{\omega_r}{2c} \right] = \omega_r T_r$$

### Relaxation Time ( $T_r$ )

Time when energy ~~becomes~~ becomes  $\left(\frac{1}{e}\right)$  times the initial energy.   
 i.e. (37%)

After that slow dissipation.   
 i.e.  $\frac{1}{e} E_0 = E_0 e^{-2ct} \Rightarrow 2ct = 1$

$$\Rightarrow T_r = \frac{1}{2c}$$

$$\frac{1}{e} = 0.368$$

~~Energy lost =  $\frac{1}{e} E_{max}$~~

~~$\int \frac{1}{2c} E_0 dt = \frac{1}{e} E_{max}$~~

~~$\frac{1}{2c} E_0 \int e^{-2ct} = \frac{1}{e} E_0$~~

~~$E_0 - E = \frac{1}{e} E_{max}$~~

~~$E = E_0 - \frac{1}{e} E_0$~~

~~$E_0 e^{-2ct} = E_0 (1 - e^{-1})$~~



# Damped Oscillation ✓

## Forced Oscillation

$$m\ddot{x} \pm -kx - b\dot{x}$$

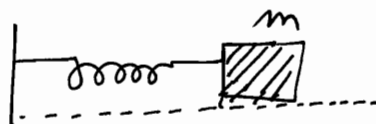

Now we apply a periodic force that supports the motion

$$F = ~~...~~ F_0 \sin pt$$

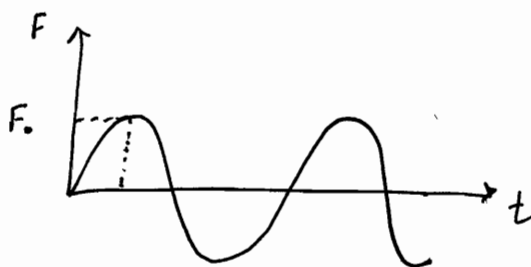

After some time, natural vibrations will die out, Now the system will vibrate according to forced motion's frequency. Hence only  $p$  is important.

$$m\ddot{x} + b\dot{x} + kx = F_0 \sin pt$$

$$\ddot{x} + 2c\dot{x} + \omega_0^2 x = f_0 \sin(pt)$$

Let the solution be  $A \sin(pt - \theta)$

$$-Ap^2 \sin(pt - \theta) + 2cA \cos(pt - \theta)$$

$$+ \omega_0^2 A \sin(pt - \theta) = f_0 \sin(pt)$$

★ This is the solution after dying out of natural frequencies. This is the particular solution.

$$f_0 = \frac{F_0}{m}$$

$$\omega_0 = \sqrt{\frac{k}{m}}$$

$$2c = \left(\frac{b}{m}\right)$$

## Quality Factor

- ⊙ In the context of resonators,  $Q$  is defined as the ratio of energy stored in the resonator to the energy supplied by the generator (or energy lost), at a frequency  $f_r$ : the resonant frequency, when stored energy is const. with time

$$Q = 2\pi \times \left( \frac{\text{Energy stored}}{\text{Energy dissipated per cycle}} \right)_{\omega = \omega_r}$$

In mechanical systems, the stored energy is the maximum possible stored energy or total energy i.e. the sum of the P.E. and K.E. at some point of time. [Note that the lost energy is the work done by an external conservative force, per cycle, to maintain Amplitude.]

- ⊙ For higher values of  $Q$ , the following definition is also mathematically accurate:

$$Q = \left( \frac{f_r}{\Delta f} \right) = \left( \frac{\omega_r}{\Delta \omega} \right)$$

Resonant Frequency  
Bandwidth

- ⊙ For  $Q < \frac{1}{2}$  : OVER DAMPED [Remember,  $Q = \frac{\omega_r}{2C}$ ]
- $Q = \frac{1}{2}$  : CRITICALLY DAMPED
- $Q > \frac{1}{2}$  : UNDER DAMPED

### Forced Oscillation

- 1) Find  $A, \theta$
- 2) Prove  $E_{dis} = E_{trans}$  in 1 cycle i.e.  $\int_0^T Fv dt$
- 3) Find condition for  $A_{res}, v_{res}, E_{dis, res}$
- 4)  $Q$  by 2 methods

# OPTICS (3)

© Beats

07/12/2011

$$\ddot{x} + 2c\dot{x} + \omega_0^2 x = f_0 \sin pt \quad \text{--- (1)}$$

$$\text{let } x = A \sin(pt - \theta)$$

$$\Rightarrow \dot{x} = pA \cos(pt - \theta)$$

$$\ddot{x} = -p^2 A \sin(pt - \theta)$$

Substituting in (1)

$$\Rightarrow -A p^2 \sin(pt - \theta) + 2cp A \cos(pt - \theta) + \omega_0^2 A \sin(pt - \theta) = f_0 \sin(\overbrace{pt - \theta} + \overline{\theta})$$

Note that negative sign with  $\theta$ .  
Of course reaction will lag the action.

↑  
Note this little trick

$$\Rightarrow (\omega_0^2 - p^2) A \sin(pt - \theta) + 2cp A \cos(pt - \theta) = f_0 \sin(pt - \theta) \cos \theta + f_0 \cos(pt - \theta) \sin \theta$$

$$\Rightarrow \left. \begin{aligned} f_0 \sin \theta &= 2cp A \\ f_0 \cos \theta &= (\omega_0^2 - p^2) A \end{aligned} \right\} \text{Comparing variables....}$$

(\*) Note that this solution is not for all time  $t > 0$ . But for time  $t > t_0$  after which the transients have died out !!!

$$\Rightarrow \tan \theta = \left[ \frac{2cp}{\omega_0^2 - p^2} \right]$$

$$A^2 = \frac{f_0^2}{(\omega_0^2 - p^2)^2 + (2cp)^2}$$

$$\Rightarrow A = \frac{f_0}{\sqrt{(\omega_0^2 - p^2)^2 + 4c^2 p^2}}$$

$$\Rightarrow x = \frac{f_0}{\sqrt{(\omega_0^2 - p^2)^2 + 4c^2 p^2}} \sin(pt - \tan^{-1} \left( \frac{2cp}{\omega_0^2 - p^2} \right))$$

⊙ Note that force external and oscillations are not in synchronization.

Hence the natural frequencies die out and system finally moves according to forced vibration. But there is some factor of natural frequency & damping in Amplitude & Phase Difference of final motion.

• Now the instantaneous energy =  $\frac{1}{2} m \dot{x}^2 + \frac{1}{2} k x^2$

⊙ Energy loss per cycle =  $\langle F \cdot v \rangle = \langle (2c\dot{x}) \dot{x} \rangle$   
 = Energy supplied per cycle  $\uparrow$  damping force

• Energy Resonance:  $p = \omega_0$   
 $\rightarrow$  energy delivered is maximum  
as well as  
energy stored is maximum

avg. per cycle  $\langle \lambda \rangle = \frac{\int_0^T \lambda dt}{T}$

This is the most important property of forced oscillations  
 $E_{\text{supplied}} = E_{\text{dissipated}}$   
 while  $E_{\text{stored}}$  remains const. for every cycle.

• Amplitude Resonance: Amplitude is maximum for every cycle.

$\rightarrow$  Note that  $c, \omega_0$  are constants of a system. The variable is  $f_0$  and  $p$

$$Q = 2\pi \frac{E_{\text{stored}}}{\left(\frac{dE}{dt}\right)_{\text{energy loss}} \times T}$$

• Energy Transfer =  $\vec{F}_0 \sin(pt) \cdot \vec{\dot{x}}$   
 per second

## Amplitude Resonance

$$\left. \frac{dA}{db} \right|_{b=b_r} = 0$$

$$\left. \frac{d^2A}{db^2} \right|_{b=b_r} < 0$$

: Conditions for  
Amplitude Resonance

$$\frac{d}{db} \left[ \frac{F_0}{m} \left[ (\omega_0^2 - b^2)^2 + 4c^2b^2 \right]^{-\frac{1}{2}} \right] = 0$$

$$2(\omega_0^2 - b^2) \cdot [-2b] + 8c^2b = 0$$

$$\Rightarrow \omega_0^2 - b^2 = 2c^2$$

$$\Rightarrow b^2 = \omega_0^2 - 2c^2$$

$$\Rightarrow \boxed{b = \sqrt{\omega_0^2 - 2c^2}}$$

$$\text{Amplitude} = \frac{F_0}{m} \left[ 4c^4 + 4c^2b^2 \right]^{-\frac{1}{2}}$$

$$= \frac{F_0}{2cm} \left[ c^2 + b^2 \right]^{-\frac{1}{2}}$$

$$= \frac{F_0}{2cm} \left[ \omega_0^2 - c^2 \right]^{-\frac{1}{2}}$$

$$\boxed{A_{\text{resonance}} = \frac{F_0}{b \sqrt{\omega_0^2 - c^2}}}$$

$$\frac{b}{m} = 2c$$

## Velocity Resonance

$$\ddot{x} = A_b \cos(pt - \theta)$$

$$= \frac{F_0 b}{m \sqrt{(\omega_0^2 - b^2)^2 + 4c^2b^2}} \cos(pt - \theta) = v(b) \cos(pt - \theta)$$

$$\left. \frac{dv}{dt} \right|_{p=p_r} = 0$$

$$\left. \frac{d^2v}{dt^2} \right|_{p=p_r} < 0$$

$$F_0 m \sqrt{(\omega_0^2 - p^2)^2 + 4c^2 p^2} + F_0 p \cdot \frac{1}{2} m (\omega_0^2 - p^2)^2 + 4c^2 p^2)^{-3/2} [2(\omega_0^2 - p^2)(-2p) + 8c^2 p] = 0$$

$$\Rightarrow 1 + \frac{p}{2} [(\omega_0^2 - p^2)^2 + 4c^2 p^2]^{-1/2} [-4p(\omega_0^2 - p^2) + 8c^2 p] = 0$$

$$\Rightarrow p^4 = \omega_0^4$$

$$\Rightarrow \omega_0 = p$$

$$\Rightarrow \boxed{p = \omega_0}$$

$$\omega_0^2 - p^2 [\omega_0^2 - p^2 + 2p^2] = 0$$

$$\Rightarrow (\omega_0^2 - p^2) (\omega_0^2 + p^2) = 0$$

$$\Rightarrow (\omega_0^2 - p^2) = 0$$

$$\Rightarrow \boxed{\omega_0 = p}$$

Energy Transfer Resonance coincides with  
velocity resonance

$$\boxed{\theta = (\pi/2)}$$

Force & velocity are synchronized.

$$\boxed{v_{\text{max}} = \left[ \frac{F_0}{2mc} \right]}$$

$$x = \frac{F_0}{2mc} \sin(pt)$$

velocity resonance does not coincide with Amplitude resonance.

# Energy Transferred Per ~~XXXXXX~~ Cycle

$$E_{\text{transferred}} = \int_T (F \cdot v) dt \quad \leftarrow \int F \cdot dx = \int F \cdot v dt$$

$$\text{Or } E_{\text{delivered}} = \int_T F_0 \sin pt \dot{x} dt \quad E = \int_T p \cdot dt$$

by impressed force per cycle

$$= \int_T F_0 \sin pt \frac{F_0 b}{m \sqrt{(\omega_0^2 - p^2)^2 + 4c^2 p^2}} dt$$

$\cos(pt - \theta) dt$   
note that  $\sqrt{\sin \theta}$  (NOT  $\cos \theta$ )  
X

$$= \int_T \left( \frac{F_0^2 b}{m \sqrt{(\omega_0^2 - p^2)^2 + 4c^2 p^2}} \right) \left[ \frac{1}{2} \sin(2pt - \theta) + \dots \right] dt$$

$\theta = \text{const.}$   
(i.e. variation of  $p$  does not affect  $\sin \theta$  much)

In 1 Time Period,  $T_0$ , Energy transferred



$$= \frac{F_0^2 b}{m \sqrt{(\omega_0^2 - p^2)^2 + 4c^2 p^2}} \cdot \frac{T_0}{2} \sin \theta$$

$$= \frac{F_0^2 b T_0 \sin \theta}{2m \sqrt{(\omega_0^2 - p^2)^2 + 4c^2 p^2}}$$

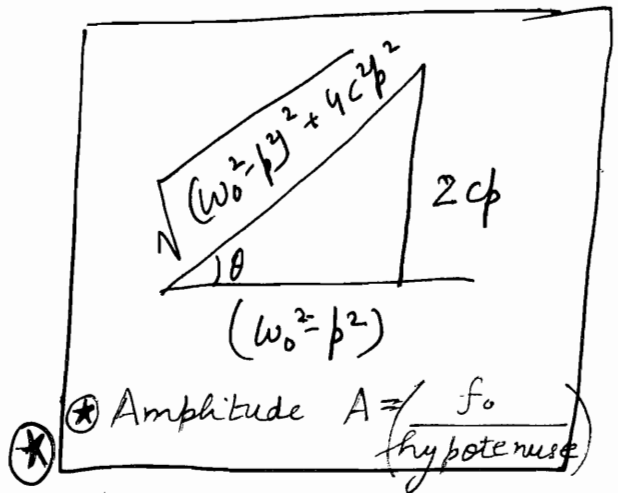

$$E_{T, \text{cycle}} = \frac{F_0^2 c b^2 T_0}{m [(\omega_0^2 - p^2)^2 + 4c^2 p^2]}$$

$$= \underline{c m A^2 b^2 T}$$

This is the same expression for Energy dissipated per cycle  $\int \mathbf{b} \cdot \mathbf{v} \cdot v dt = \int 2cv^2 dt$

# Energy transfer Resonance

$$\left. \frac{dE_{T, cycle}}{d\beta} \right|_{\beta = \beta_r} = 0$$

$$\left. \frac{d^2 E_{T, cycle}}{d\beta^2} \right|_{\beta = \beta_r} < 0$$

$$\Rightarrow \boxed{\beta = \omega_0}$$

⊙ Note that the variable part is nothing but the square of the expression used in velocity resonance

Energy transferred to system by external force in time period  $T_0$  @ resonance

$$E_{T, cycle} @ \text{resonance} = \frac{F_0^2 T_0}{4mc}$$

$$\text{Power} = \frac{F_0^2 c \beta^2}{m [(\omega_0^2 - \beta^2)^2 + 4c^2 \beta^2]}$$

Avg. Power delivered in 1 Time Period

$$m [(\omega_0^2 - \beta^2)^2 + 4c^2 \beta^2]$$

Note that Power Transfer Resonance is same as energy transfer resonance which is same as velocity resonance.

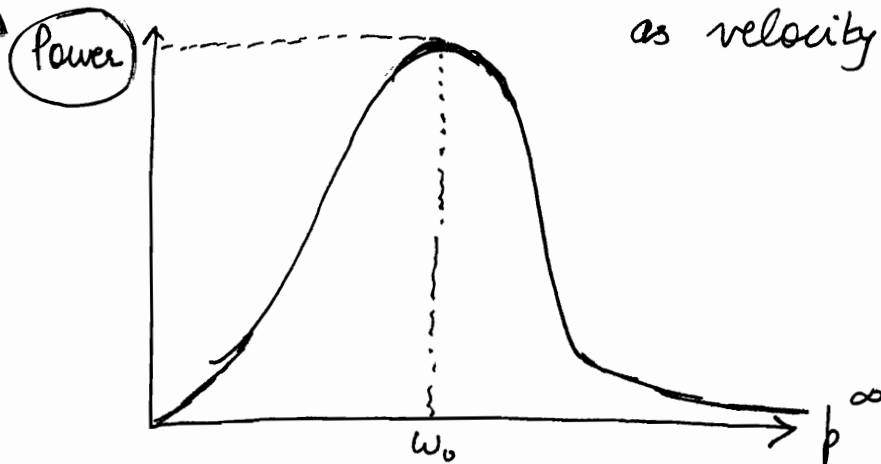

- ① For energy resonance, we always calculate resonance of  $E_{transferred}$  or  $E_{dissipated}$ . Never do we calculate  $E_{stored}$  resonance. (Actually, that is not a  $\beta = \omega_0$  but slightly shifted)
- ②  $E_{dissipated}$  per cycle =  $E_{transferred}$  per cycle. Calculating former is much simpler.  
 $\langle 2cm v. v T_0 \rangle = \frac{F_0^2 c \beta^2 T_0}{m [(\omega_0^2 - \beta^2)^2 + (2c\beta)^2]}$



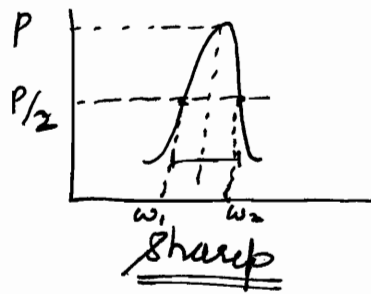
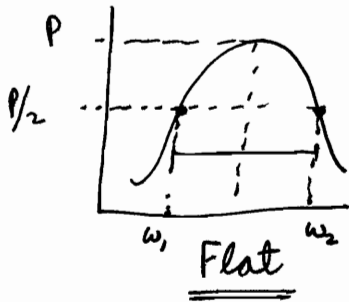

In order to determine sharpness of curve, we measure half-power frequencies  $\omega_1, \omega_2$ .

$[\omega_2 - \omega_1]$  is called Bandwidth.

More the Bandwidth, flatter the curve.

→ Quality Factor is a measure of sharpness of resonance. Higher the  $Q$ , sharper the resonance.

$$Q \propto \text{sharper} \propto \frac{1}{BW}$$

$$Q \propto \left[ \frac{\text{Resonant Frequency}}{\text{Bandwidth}} \right] \leftarrow \text{sharpness}$$

[ The rapidness with which the Power delivered falls with slight change in frequency from 'resonant frequency': that is a measure of sharpness. ]

Actually,  $Q = \left[ \frac{\text{Resonant Frequency}}{\text{Bandwidth}} \right]$

↗  
 $Q$  obtained from both the definitions turns out to be same !!

# Half Power Frequencies

$$\frac{F_0^2 c b^2}{m[(\omega_0^2 - b^2)^2 + 4c^2 b^2]} = \frac{1}{2} \frac{F_0^2}{4mc} \Rightarrow 8c^2 b^2 = (\omega_0^2 - b^2)^2 + 4c^2 b^2$$

$$\Rightarrow \omega_0^2 - b^2 = \pm 2cb$$



$$\Rightarrow b = \pm 2c \pm \sqrt{c^2 + \omega_0^2} = \sqrt{c^2 + \omega_0^2} + c, \sqrt{c^2 + \omega_0^2} - c \Rightarrow \Delta b = 2c$$

(b<sub>2</sub>) When  $\omega_0 < b$

$$\omega_0^2 - b^2 = -2cb$$

$$\Rightarrow b^2 + 2cb - \omega_0^2 = 0 \Rightarrow b = -c + \sqrt{c^2 + \omega_0^2}$$

( $\because b > \omega_0$  &  $b > 0$ )

(b<sub>1</sub>)  $\omega_0 > b$

$$\omega_0^2 - b^2 = 2cb$$

$$\Rightarrow b^2 - 2cb - \omega_0^2 = 0 \Rightarrow b = c + \sqrt{c^2 + \omega_0^2}$$

$$\Rightarrow Q = \frac{\omega_0}{2c} \quad \star \text{ Perfect (Credited)}$$

## Energy Stored Resonance

$$\text{Energy stored} = \frac{1}{2} kx^2 + \frac{1}{2} m\dot{x}^2$$

$$= \frac{1}{2} kA^2 \sin^2(\omega t - \theta) + \frac{1}{2} m b^2 A^2 \cos^2(\omega t - \theta)$$

$$\text{Avg. Energy stored} = \frac{1}{2} kA^2 \cdot \frac{1}{2} + \frac{1}{2} m b^2 A^2 \cdot \frac{1}{2}$$

$$= \frac{1}{4} kA^2 \left[ 1 + \frac{b^2}{\omega_0^2} \right]$$

$$E_{\text{stored avg}} = \frac{1}{4} \frac{k F_0^2}{m^2} \left( 1 + \frac{b^2}{\omega_0^2} \right) \frac{1}{m^2 [(\omega_0^2 - b^2)^2 + 4c^2 b^2]}$$

Since non conservative forces are acting & external energy is also being applied,  $E_{\text{stored}}$  varies with time periodically. This is the avg. of energy stored.

Energy stored Maximum  $\Rightarrow$

~~$\beta = \omega_0$~~

Note exactly @  $\beta = \omega_0$  but close to  $\beta = \omega_0$  ..... Note that @ resonance, Energy transferred (= Energy lost) is maximum only. Maximum Energy Stored

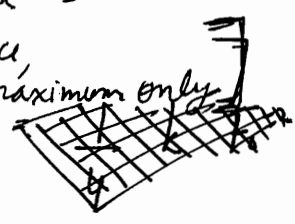

⊛ Resonance of  $\omega$   
~~transferred~~  
 energy (which is equal to lost energy)  
~~occurring~~  
 at  $\beta = \omega_0$   
 Note that we talk about avg. energy per cycle in all cases

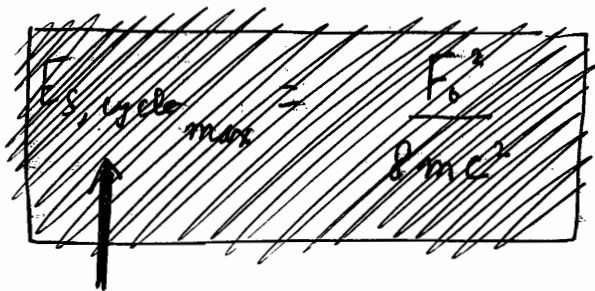

⊛ Note that here we put  $\beta = \omega_0$ , not  $\beta = \omega$ . Stored is max at  $\beta = \omega_0$  (its not actually), but  $\beta = \omega$  by def<sup>n</sup> of Q  
 $Q = 2\pi \left( \frac{\text{Energy stored}}{\text{Energy per cycle}} \right) \omega = \omega_0$

~~Max Energy stored in the system is independent of time. This is wrong.~~  
 Energy maxima

$$\text{Energy loss per second} = \int b \dot{x}^2 dt$$

$$\text{cycle} = \int 2mc \dot{x}^2 = \int 2mc \beta^2 A^2 \cos^2(\beta t - \theta) dt$$

Avg. Energy loss =  $2mc \beta^2 A^2 \frac{T}{2}$

Energy loss per cycle =  $mc \beta^2 A^2 T$

⊙ Since E stored, avg remains same cycle per cycle, energy transmitted = energy lost =  $mc \beta^2 A^2 T$ .

$$Q = \frac{2\pi \cdot \frac{A^2}{4} [k + m\beta^2]}{mc\beta^2 A^2 \cdot T}$$

$$\frac{2\pi}{T} = \beta$$

$$= \frac{k + m\beta^2}{4 m c \beta}$$

$$Q = \frac{\omega_0^2 + \beta^2}{4c\beta} = \frac{\beta}{4c} \left[ 1 + \frac{\omega_0^2}{\beta^2} \right]$$

@  $\beta = \omega_0$   
 $Q = \frac{\omega_0}{4c} [1 + 1]$

⊛  $Q = \frac{\omega_0}{2c}$

$$E_T = E_S + E_L \dots \text{instantaneously} \quad |1) \quad \alpha_1 = \alpha_2 \quad ?? \quad \text{same}$$

$$|2) \quad E_T = E_S + E_L; \text{ in To } \underline{E_T = E_L}$$

## Superposition of Waves

When 2 or more waves disturb a medium simultaneously, their combined influence is called superposition.

Like waves, superposition is w.r.t. space and time.

|                              |              |
|------------------------------|--------------|
| Superposition w.r.t. Space : | INTERFERENCE |
| Superposition w.r.t. Time :  | BEATS        |

### BEATS

For simplicity, we take 2 1-d waves.

$$y_1 = a \sin(\omega_1 t - k_1 x)$$

$$y_2 = a \sin(\omega_2 t - k_2 x)$$

$$y = y_1 + y_2$$

For Beats,  $x = \text{const}$  let  $x = 0$

$$\Rightarrow y = a \sin \omega_1 t + a \sin \omega_2 t$$

No Beats if  $\omega_1 = \omega_2$

$$y = 2a \sin\left(\frac{\omega_1 + \omega_2}{2} t\right) \cos\left(\frac{\omega_1 - \omega_2}{2} t\right)$$

$$= 2a \cos\left(\left[\frac{\omega_1 - \omega_2}{2}\right] t\right) \sin\left[\left(\frac{\omega_1 + \omega_2}{2}\right) t\right]$$

Amplitude

$\uparrow$   
 $\sin(\omega_{\text{avg}} t)$

$$y = 2a \cos\left[\left(\frac{\omega_1 - \omega_2}{2}\right)t\right] \sin \bar{\omega}t$$

Intensity (t)  $\propto A^2$

$$\propto 4a^2 \cos^2\left(\frac{\omega_1 - \omega_2}{2}\right)t$$

$$\text{Intensity} = I_0 \cos^2\left[\left(\frac{\omega_1 - \omega_2}{2}\right)t\right]$$

$\odot \cos A + \cos B$   
 $= 2\cos\left(\frac{A+B}{2}\right) \cos\left(\frac{A-B}{2}\right)$   
 $\Rightarrow I = I_0 \cos^2\left[\left(\frac{\omega_1 - \omega_2}{2}\right)t\right]$   
 $\star$  always

$I_0 = I_{\max} = \text{Four times the normal intensity}$

Intensity =  $I_0$  when  $\left(\frac{\omega_1 - \omega_2}{2}\right)t = n\pi$

$$\Rightarrow t = \frac{\pi}{(f_1 - f_2)}$$

$$= 0, \frac{1}{(f_1 - f_2)}, \frac{2}{(f_1 - f_2)}, \dots$$

$\cos\left(\frac{\Delta\omega}{2}\right)$  की दृष्टि से HALF  
 $\cos^2$  की दृष्टि से DOUBLE freq.  
 $\Rightarrow f = \Delta f$

Beats Frequency =  $(f_1 - f_2)$  Hz : No. of times we hear loud sound in a second.

Beats are heard when  $(f_1 - f_2) < 10$

### Application

✓ To know the frequency of unknown tuning fork.

By filing the tuning fork, frequency is increased

By waxing the tuning fork, frequency is reduced.

Q 3 tuning forks of successive frequencies are sounded together. What is beat frequency

Ans  $(\nu - \nu'), (\nu), (\nu + \nu')$

$$a [\sin(\omega - \omega')t + \sin \omega t + \sin(\omega + \omega')t]$$

$$2a [\sin(\omega t) \cos(\omega' t) + \frac{\sin \omega t}{2}]$$

$$\underline{2a \sin \omega t} \left[ \frac{1 + \cos \omega' t}{2} \right]$$

$\omega'$

$$\Rightarrow I \propto \left( \frac{1}{2} + 2 \cos \omega' t \right)^2$$

$$= (1 + 4 \cos^2 \frac{\omega' t}{2} - 1)$$

$$= 16 \cos^4 \left( \frac{\omega' t}{2} \right)$$

$$f = \frac{\left( \frac{2\omega'}{2} \right)}{2\pi} = \frac{\omega'}{2\pi} = \underline{\underline{\nu'}}$$

$$I \propto \left[ \frac{1}{4} + \cos^2 \omega' + \cos \omega' \right]$$

$$\uparrow$$

$$T = \left( \frac{\pi}{\omega'} \right)$$

$$\uparrow$$

$$T = \left( \frac{2\pi}{\omega'} \right)$$

$$\Rightarrow \text{LCM} = \left( \frac{2\pi}{\omega'} \right)$$

$$\Rightarrow f = \frac{2\pi}{\frac{2\pi}{\omega'}} = \omega'$$

∴ A.P. की difference  $\frac{\omega'}{2}$ ,  
∴ Beat Frequency  $\frac{\omega'}{2}$ !!

⊛ General solution of forced oscillations is

$$y = \frac{A e^{-\lambda t} \sin(\omega t + \phi)}{\text{Homogeneous sol}^n} + \frac{B \sin(pt - \theta)}{\text{particular solution}}$$

We may safely assume the underdamped case, it is the most prevalent case.

First term is transient solution which eventually die out. 2<sup>nd</sup> term is steady state solution.

⊛ There is no amplitude resonance in case of.

$$\omega_0^2 < 2c^2$$

ie.

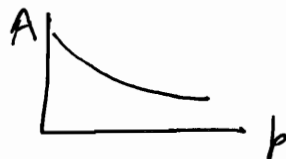

# OPTICS (4)

© Standing Waves 08/12/2011

## Standing Waves

2 waves travelling in opposite direction superimpose.

If same  $A$  and  $\omega$ , the 2 waves now become standing or stationary waves. They do not transport any energy /  $\vec{p}$ .

Energy is confined within the 2 sources.

There are certain points having no displacement.

We can observe standing waves via reflection of a single wave.

There is change of  $\phi$  ( $\Delta\phi = \pi$ ) apart from direction change if reflected from very heavy medium.

$$y_1 = a \sin(\omega t - kx)$$

$$\oplus \frac{d\phi}{dt} = 0 \Rightarrow \omega - k \frac{dx}{dt} = 0 \Rightarrow \frac{dx}{dt} = \frac{\omega}{k}$$

[travelling along +x axis]

To find direction  $v_{\text{phase}} = \frac{\omega}{k}$  which is  $\oplus$ ve

→ There can be 4 types of incident waves:  $a \sin(\omega t \mp kx)$

depending upon initial conditions and direction of movement.

$$a \cos(\omega t \mp kx)$$

✓  $y_2 = a \sin(\omega t + kx)$

..... free boundary reflection

✓  $y_2 = a \sin(\omega t + kx + \pi)$

..... rigid boundary reflection

$$\text{let } y_1 = a \sin(\omega t - kx)$$

$$y_2 = -a \sin(\omega t + kx)$$

[rigid body reflection]

$$y = y_1 + y_2$$

$$= a [\sin(\omega t - kx) - \sin(\omega t + kx)]$$

$$= -2a [\sin(kx) \cos(\omega t)]$$

Only 4 types:

|                                |
|--------------------------------|
| $y = 2a \cos kx \sin \omega t$ |
| $2a \sin kx \sin \omega t$     |
| $2a \cos kx \cos \omega t$     |
| $2a \sin kx \cos \omega t$     |

★ जित Expression boundary conditions को suit करे, वही Expression ही !!

★ Note that if reflected from hard medium, the nodes will be antinodes if reflected from soft medium.

let us have  $y = 2a \cos kx \sin \omega t$

Antinode:  $y = y_{\max}$

Node  $y = 0$

$$y = 2a \omega \cos kx \cos \omega t$$

we will prove this for a longitudinal wave .....  
(refer end of copy for proof)

We are interested in waves per unit area per unit time

Average Energy carried by standing

$$= \frac{\int_0^T \frac{F}{A} \dot{y} dt}{T}$$

$$= \frac{1}{T} \int_0^T P \dot{y} dt$$

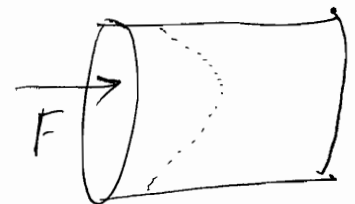



Pressure is governed by Bulk Modulus

$$k = \frac{P}{-\left(\frac{dv}{v}\right)}$$

$$\Rightarrow P = -k \left(\frac{dv}{v}\right)$$

external force जो काम करता है, वह energy carried out आता है transfer करता है !!  $= \int \vec{F} \cdot \vec{v} dt$   
 $\rightarrow v$  particle velocity in direction

Nodes का relation  $f(x)$  से होता है,  $\left(\frac{dx}{dt}\right)$  does not change  $f(x)$

Note that behaviour of  $y$  and  $\dot{y}$  are similar.  
 Nodes of velocity & displacement are same. ( $\cos x$ )

Note that,  $\left(\frac{dv}{v}\right) = \left(\frac{\partial y}{\partial x}\right)$  : Volumetric strain

Note that behaviour of strain and Pressure is same. ( $\sin x$ )

$$\left(\frac{\partial y}{\partial x}\right) = -2ak \sin kx \sin \omega t$$

disp. Nodes का relation  $f(x)$  से है; Pressure का relation  $\left(\frac{\partial y}{\partial x}\right)$  से है, hence opposite behaviour

Note that displacement & strain have opposite behaviour.  
 Nodes of displacement are antinodes of strain.  
 [ $\sin x$  vs  $\cos x$ ]

Note that E per unit area per unit time,

$$\begin{aligned} &= \frac{1}{T} \int_0^T P \dot{y} dt = \frac{1}{T} \int_0^T (2a)^2 k^2 \omega^2 \sin kx \sin \omega t \cdot \cos kx \cos \omega t dt \\ &= \frac{a^2 k^2 \omega^2}{T} \int_0^T \sin(2kx) \sin(2\omega t) dt \\ &= \frac{a^2 k^2 \omega^2}{T} \sin(2kx) \int_0^T \sin(2\omega t) dt = 0 \end{aligned}$$

① We are interested in : displacement  
velocity  
volumetric strain  
Pressure

Note that in stationary waves, there is no net transfer of energy when a string is vibrating in a particular mode. But each element of string is associated with a certain energy density. Energy density is maximum at ANTINODES and minimum at NODES....

### displacement nodes

if  $y = 2a \cos kx \sin \omega t$

$$y = 0 \quad \forall t$$

$$\Rightarrow \cos kx = 0$$

$$\Rightarrow kx = (2n+1) \frac{\lambda}{2}$$

$$\Rightarrow \frac{2\pi}{\lambda} x = (n+1) \frac{\pi}{2}$$

$$\Rightarrow x = \left(n + \frac{1}{2}\right) \frac{\lambda}{2}$$

$$x = \frac{\lambda}{4}, \frac{3\lambda}{4}, \frac{5\lambda}{4}, \dots$$

velocity nodes  
Pressure antinodes  
Strain antinodes

→ Note  $y$  can be any of the 4 types depending upon requirement !!!

### displacement antinodes

$$y = 2a \cos kx \sin \omega t$$

$$y = \max \quad \forall t$$

$$\Rightarrow \cos kx = \pm 1$$

$$\Rightarrow kx = n\pi \quad \Rightarrow \frac{2\pi}{\lambda} x = n\pi \quad \Rightarrow x = \left(\frac{n\lambda}{2}\right)$$

$$\Rightarrow x = 0, \frac{\lambda}{2}, \lambda, \frac{3\lambda}{2}, \dots$$

velocity antinodes  
Pressure Node  
strain Node

Note that Nodes & Antinodes alternate.

Difference b/w successive nodes is  $(\frac{\lambda}{2})$

Difference b/w successive antinodes is  $(\frac{\lambda}{2})$

Difference b/w adjacent node & antinode =  $(\frac{\lambda}{4})$

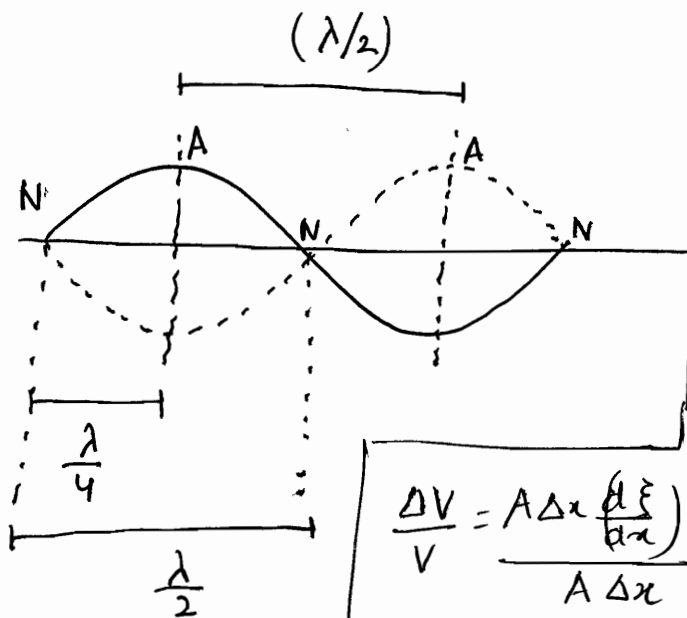

refer to Tut2Q-14  
for derivation.

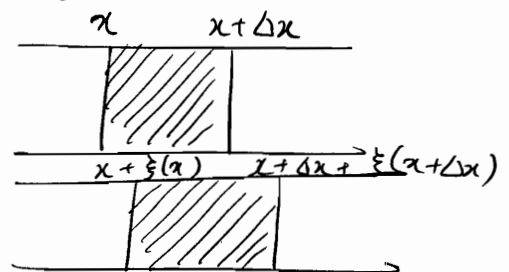

$$\frac{\Delta V}{V} = \frac{A \Delta x \left( \frac{d\xi}{dx} \right)}{A \Delta x} = \left( \frac{d\xi}{dx} \right)$$

Volumetric Strain

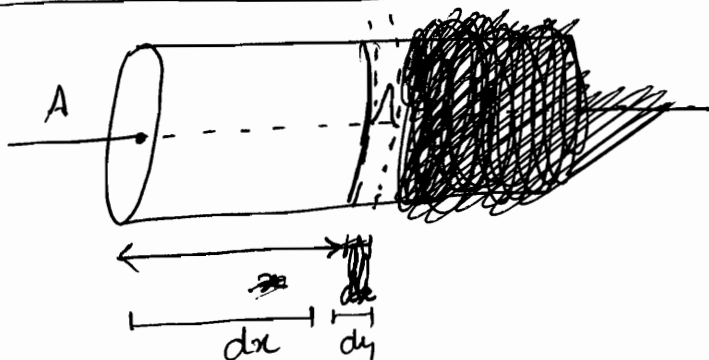

let us consider a differential volume  
 $V = A dx$   
let the displacement of longitudinal wave be  $dy$   
 $\Rightarrow dV = dy \cdot A \Rightarrow \left( \frac{dV}{V} \right) = \left( \frac{dy}{dx} \right)$

$$V_i = A dx$$

$$V_f = A \left[ dx + \frac{\partial y}{\partial x} \cdot dx \right]$$

$$V_f - V_i = A \left( \frac{\partial y}{\partial x} \right) \cdot dx$$

$$\frac{V_f - V_i}{V_i} = \left[ \frac{\partial y}{\partial x} \right]$$

We can have standing waves in columns or strings or rods.....

## Column

eg. Organ pipes

Open Column: Both ends open



✓ Closed Column: 1 end open, 1 end closed



Fundamental Tone or 1<sup>st</sup> Harmonic: Minimum frequency that can be produced.  
(f)

2f: 1<sup>st</sup> Overtone or 2<sup>nd</sup> Harmonic

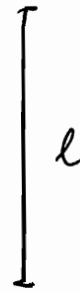
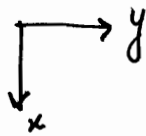
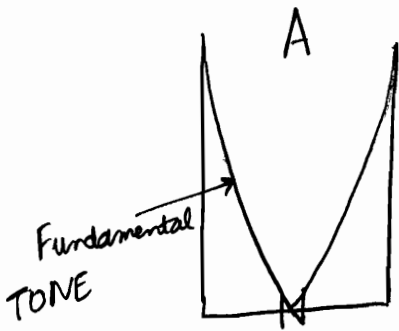

$$l = \left(\frac{\lambda}{4}\right)$$

$$\Rightarrow \lambda = 4l$$

$$v_1 = \frac{v}{\lambda} = \left[\frac{v}{4l}\right] \leftarrow 1^{\text{st}} \text{ Harmonic}$$

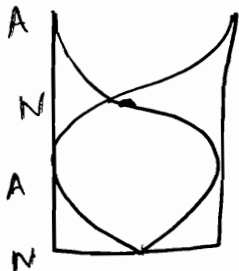

$$l = \left(\frac{3\lambda}{4}\right) \quad v_2 = \frac{v}{\lambda} = \left[\frac{3v}{4l}\right] \leftarrow 3^{\text{rd}} \text{ Harmonic}$$

Only Odd Harmonics are there

$$\nu_1 : \nu_2 : \nu_3 = 1 : 3 : 5$$

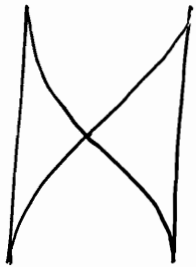

$$l = \frac{\lambda}{2}$$

$$\nu_1 = \frac{v}{\lambda} = \left( \frac{v}{2l} \right)$$

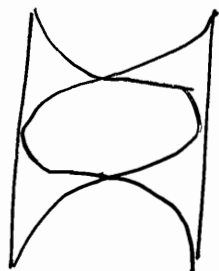

$$l = \lambda$$

$$\nu_2 = \frac{v}{\lambda} = \left( \frac{v}{l} \right)$$

$$\nu_1 : \nu_2 : \nu_3 = 1 : 2 : 3$$

## Rods

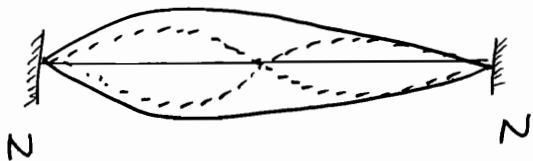

Tied at Both ends

$$l = \left( \frac{\lambda}{2} \right)$$

$$\nu_1 = \left( \frac{v}{2l} \right)$$

$$\nu_1 : \nu_2 : \nu_3 = 1 : 2 : 3$$

$$l = \lambda$$

$$\nu_2 = \left( \frac{v}{l} \right)$$

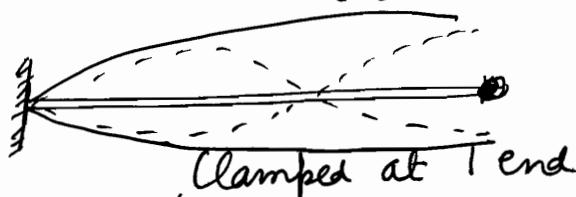

Clamped at 1 end

$$l = \frac{\lambda_1}{4}$$

$$\nu_1 = \left( \frac{v}{4l} \right)$$

$$\nu_1 : \nu_2 : \nu_3 = 1 : 3 : 5$$

$$l = \frac{3\lambda_2}{4}$$

$$\nu_2 = \left( \frac{3v}{4l} \right)$$

Energy density in standing wave:  
 $y = 2A \cos kx \sin \omega t$

$$dE = \frac{1}{2} dm v^2$$

$$= \frac{1}{2} \rho \cdot dl \cdot 4A^2 \omega^2 \cos^2 kx \sin^2 \omega t$$

At nodes

$$\frac{dE}{dl} = 2\rho A^2 \omega^2 \cos^2 \omega t$$

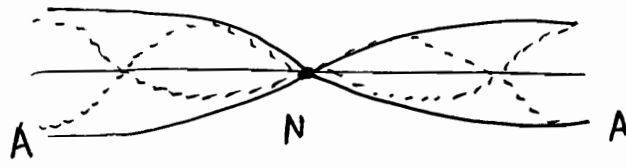

Clamped at middle

$$l = \frac{\lambda}{2} \Rightarrow \nu_1 = \left( \frac{v}{2l} \right)$$

$$l = \frac{3\lambda}{2} \Rightarrow \nu_2 = \left( \frac{3v}{2l} \right)$$

$$\nu_1 : \nu_2 : \nu_3 = 1 : 3 : 5$$

Vibration of strings example is sonometer.

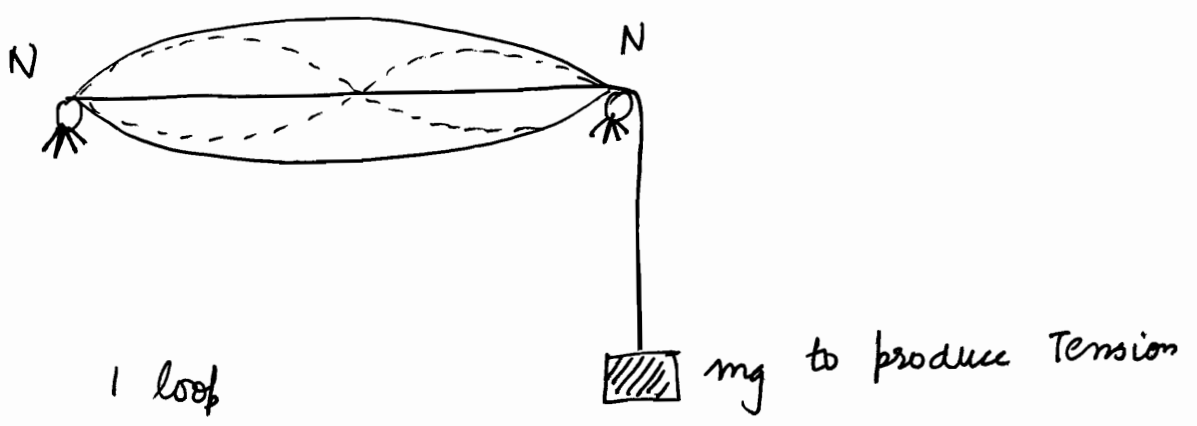

$$l = \frac{\lambda}{2} \quad 1 \text{ loop}$$

$$l = \lambda \quad 2 \text{ loop}$$

$$l = \left( \frac{k\lambda}{2} \right) \quad k \text{ loops} \Rightarrow \nu = \frac{kv}{2l} = \left[ \frac{k}{2l} \sqrt{\frac{T}{m}} \right]$$

where  $\nu = \sqrt{\frac{T}{\lambda}}$   
 $T = \text{Tension}$   
 $m = \text{Mass/length}$

11 <sup>Text</sup>  
7B

$$k = \frac{1}{2} m \dot{y}^2$$
$$= \frac{1}{2} \rho l \dot{y}^2$$



If we assume

$$y = 2a \cos kx \sin \omega t$$

$$\dot{y} = 2a\omega \cos kx \cos \omega t$$

$$E = \left(\frac{k}{l}\right) = \frac{1}{2} \rho l \cdot \frac{1}{2} a^2 \omega^2 \cos^2 kx \cos^2 \omega t$$

at antinodes

$y_{\text{max}}$  @ antinode :  $\cos kx = 1$   
 $\Rightarrow \cos^2 kx = 1$

$\Rightarrow$  Contradiction

Assume  $y = 2a \sin kx \sin \omega t \dots$

NOW no contradiction

g

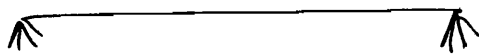

$$y = a \sin(\omega t - kx)$$

$$= a \sin\left[\omega\left(t - \frac{x}{v}\right)\right]$$

$$y_2 = a \sin\left(\omega\left(t + \frac{x}{v}\right) + \pi\right)$$

★ SONOMETER

$T = f(mg)$

•  $v \propto \sqrt{T}$

•  $v \propto \frac{1}{\sqrt{\lambda}}$

$\lambda = \frac{M}{L}$

•  $v \propto \frac{1}{l}$

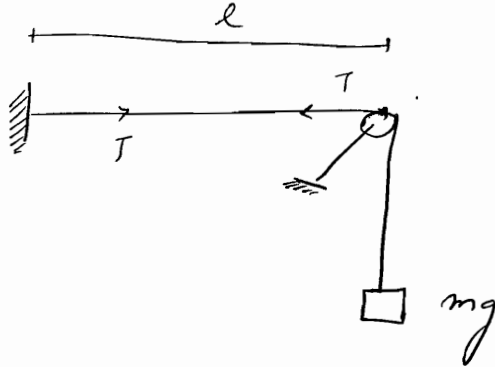

Sonometer is a device to study relationship between frequency of sound & Tension, length, mass per unit length.

★ In geometrical optics, finiteness of the wavelength is neglected i.e.  $\lambda \rightarrow 0$ . Hence the effects like diffraction caused due to finiteness of the wave are neglected.

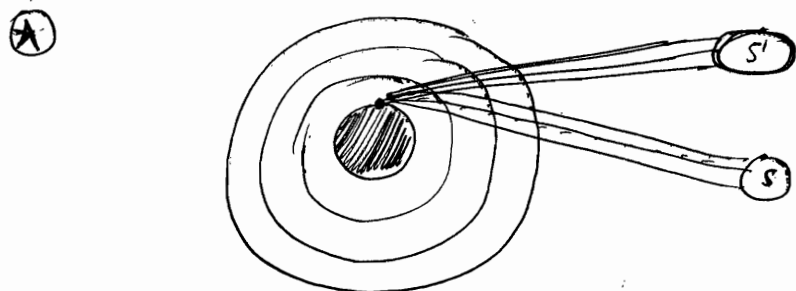
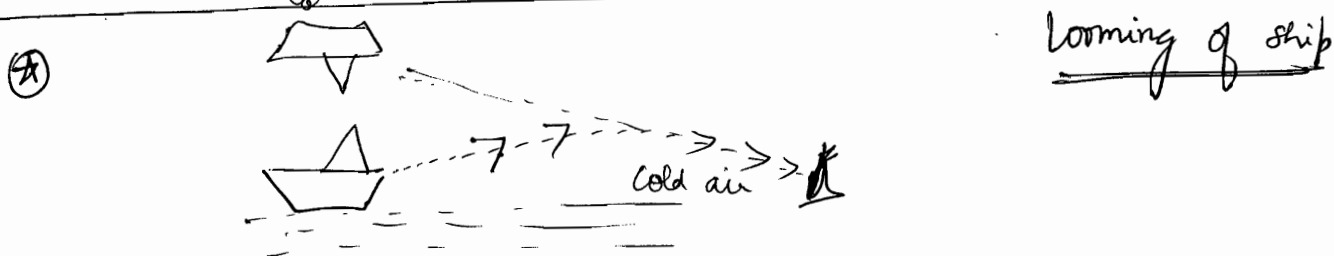

Refraction responsible for

- ① Non circular shape of sun
- ② Days are usually 5 min longer than they had been in absence of atmosphere.



# OPTICS (5)

- ⊙ Fermat's Principle
- ⊙ Chromatic Aberration 09/12/11
- ⊙ Spherical Aberration

## GEOMETRICAL OPTICS

Geometrical Optics also called Para Axial Optics i.e. all ideal rays are parallel to Principal Axis.

Even if they are not parallel, the angle is so small that

$$\cos \theta \approx 1$$

$$\sin \theta \approx \theta$$

$$\tan \theta \approx \theta$$

### Fermat's Principle

① def<sup>n</sup>

② reflection

③ refraction

④ spherical surface refraction

⑤ lens formula

⑥ Mirror formula

⑦ Path maxima inside sphere

Optical Path chosen for travel of light from source to destination is "Optimum path".

" A ray of light starting from a particular point to a particular destination through a no. of reflections or refractions chooses that path which is OPTIMUM/EXTREMUM (i.e. maxima/minima/stationary) "

A & B are fixed

$$\text{Time} = \frac{ds}{v} = \frac{ds}{(c/\mu)} = \frac{[\mu ds]}{c}$$

$[\mu ds]$  is the optimum path.

It is an extremum i.e. derivative = 0

$$\boxed{S = \mu (AB)}$$

$$\frac{d}{dt} \int \mu ds = 0$$

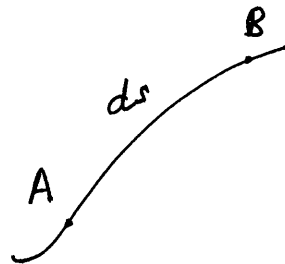

# Reflection

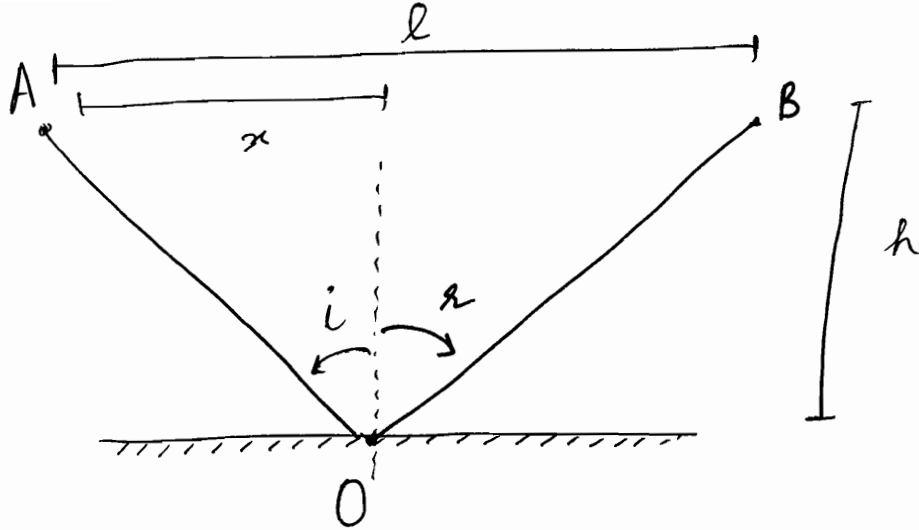

- There is relationship between  $i$  and  $r$ ,
- for a given A, we have a fixed B and variable O.

$$\Rightarrow AB = \text{fixed} = l$$

$\rightarrow$   $x$  is variable, i.e. O is variable

$$S = \mu[AO] + \mu[OB]$$
$$= \mu \left[ \sqrt{x^2 + h^2} + \sqrt{h^2 + (l-x)^2} \right]$$

$$\frac{dS}{dx} = 0 \quad \text{According to Fermat's principle}$$

$$\frac{1}{2} [x^2 + h^2]^{1/2} \cdot 2x - \frac{1}{2} [h^2 + (l-x)^2]^{1/2} \cdot 2(l-x) = 0$$

$$\Rightarrow \sin i - \sin r = 0$$

$$\Rightarrow \sin i = \sin r$$

$$\Rightarrow \boxed{i = r}$$

# Refraction

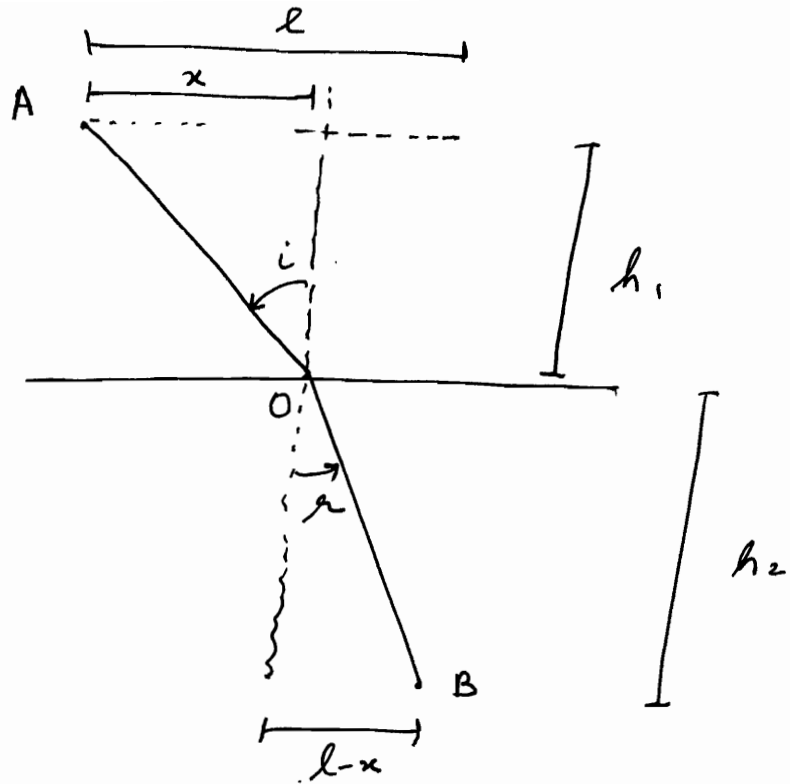

$$S = \mu_1 AO + \mu_2 OB$$

$$= \mu_1 \sqrt{x^2 + h_1^2} + \mu_2 \sqrt{h_2^2 + (l-x)^2}$$

$$\frac{ds}{dx} = 0$$

$$\Rightarrow \frac{1}{2} \mu_1 \frac{2x}{\sqrt{x^2 + h_1^2}} + \mu_2 \frac{2(l-x)}{\sqrt{h_2^2 + (l-x)^2}} = 0$$

$$\Rightarrow \mu_1 \sin i - \mu_2 \sin r = 0$$

$$\Rightarrow \boxed{\mu_1 \sin i = \mu_2 \sin r}$$

Q1)

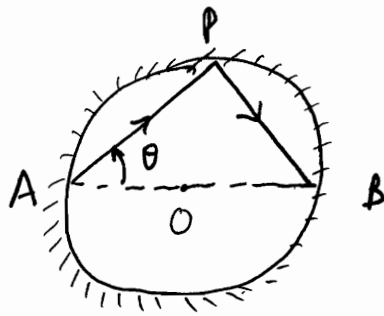

$$S = \mu [AP + PB]$$
$$= \mu [2R \cos \theta + 2R \sin \theta]$$

$$\frac{dS}{d\theta} = 0 \Rightarrow \underline{\underline{\theta = 45^\circ}}$$

$$\left. \frac{d^2S}{d\theta^2} \right|_{\theta=45^\circ} = - \left[ \frac{1}{\sqrt{2}} + \frac{1}{\sqrt{2}} \right] < 0 \Rightarrow \underline{\underline{\text{Maximum Path}}}$$

Q2)

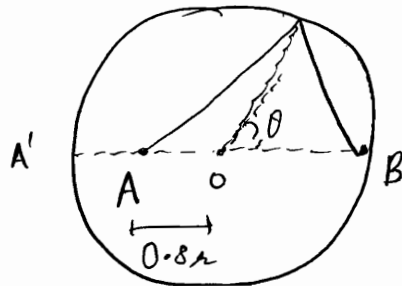

$$S = \mu \left[ \sqrt{R^2 + (0.8R)^2 + 2R(0.8R) \cos \theta} + \sqrt{R^2 + R^2 - 2R^2 \cos \theta} \right]$$

$$\frac{dS}{d\theta} = 0$$

# Refraction from a spherical surface.

Choose the acute angle as  $\theta$

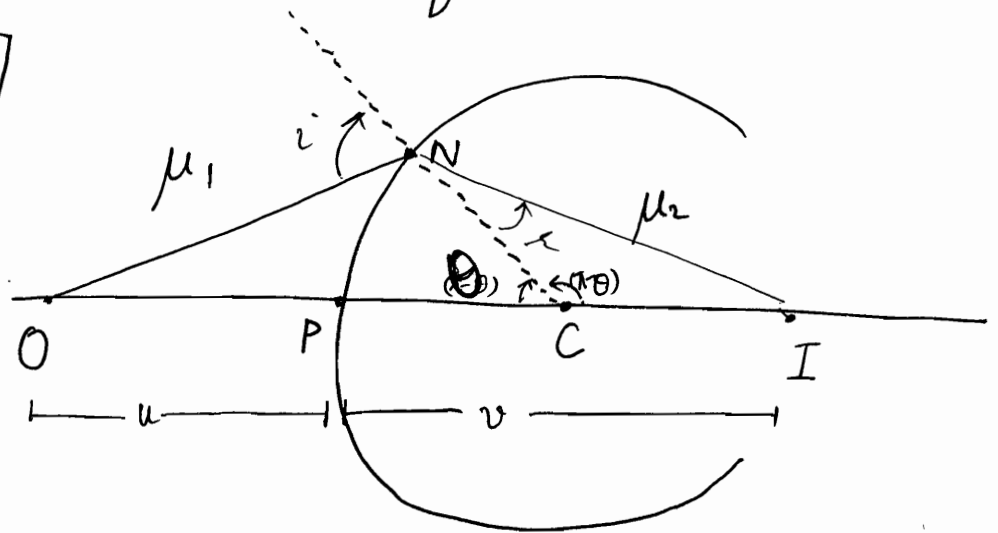

line joining C to any point N, CN is normal to surface at N.

$$S = \mu_1 ON + \mu_2 NI$$

$$OC = u + R$$

$$CI = v - R$$

$$S = \mu_1 \sqrt{(u+R)^2 + R^2 - 2R(u+R) \cos(\pi-\theta)} + \mu_2 \sqrt{(v-R)^2 + R^2 - 2R(v-R) \cos(\pi-\theta)}$$

$$\frac{dS}{d\theta} = 0$$

$$\mu_1 \frac{1}{2} + \frac{[2R(u+R) \sin \theta]}{\lambda_1^{1/2}} + \mu_2 \frac{1}{2} \frac{[-2R(v-R) \sin \theta]}{\lambda_2^{1/2}} = 0$$

$$\Rightarrow \frac{\mu_1}{\lambda_1^{1/2}} (u+R) = \frac{\mu_2}{\lambda_2^{1/2}} (v-R)$$

Now assuming paraaxial optics

$$\Rightarrow \frac{\mu_1 (u+r)}{\sqrt{(u+r)^2 + R^2 - 2R(u+r)}} = \frac{\mu_2 (v-R)}{\sqrt{(v-R)^2 + R^2 + 2R(v-R)}}$$

$$\Rightarrow \frac{\mu_1 (u+r)}{(u+r)} = \frac{\mu_2 (v-R)}{v}$$

$$\Rightarrow \mu_1 \left[ 1 + \frac{r}{u} \right] = \mu_2 \left[ 1 - \frac{R}{v} \right]$$

$$\Rightarrow \boxed{\frac{\mu_2}{v} + \frac{\mu_1}{u} = \frac{\mu_2 - \mu_1}{R}}$$

Till now, we have not used any sign convention

Using sign convention

→ if you are taking sign conventions from the very beginning, then take  $\sqrt{u^2} = -u$

$$\boxed{\frac{\mu_2}{v} - \frac{\mu_1}{u} = \left( \frac{\mu_2 - \mu_1}{R} \right)}$$

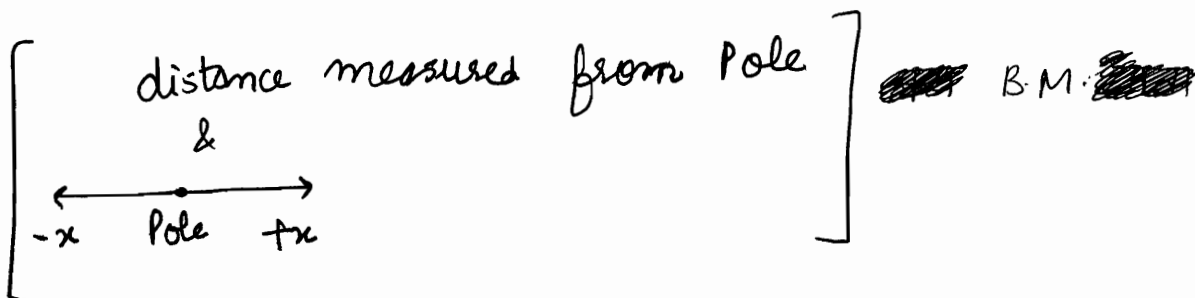

# Aberration

Aberration means deviation from ideal behaviour.

Ideal Behaviour: Point Image of a point object.

If not this behaviour  $\Rightarrow$  aberration.

Chromatic Aberration

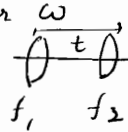
- ① concept
- ② types
- ③ dispersive Power  $\omega$  &  $df = \omega f$
- ④ 3 conditions 

Focal length =  $f$  (refractive index  $\mu$ )

$$\mu = f(\lambda)$$

$\Rightarrow$  Focal length varies according to colour.

$$\frac{1}{f} = (\mu - 1) \left[ \frac{1}{R_1} + \frac{1}{R_2} \right]$$

⊛ (lens maker's formula)  
i.e. R<sub>1</sub> "1-2", R<sub>2</sub> "2-1" etc!!

$$\mu = \left( \frac{c}{v} \right)$$

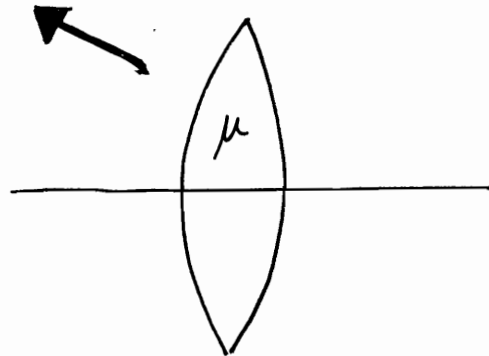

$\mu$  maximum for blue

~~maximum for blue~~

$\mu$  minimum for red

$$v \propto \lambda$$

$$v = \frac{\lambda}{\gamma}$$

$$\mu \propto \frac{1}{v} \Rightarrow \mu \propto \frac{1}{\lambda}$$

$$\mu \propto \frac{1}{v}$$

$$f \propto \frac{1}{\mu} \Rightarrow f \propto \lambda$$

$$\Rightarrow \mu \propto \frac{1}{\lambda}$$

Focus maximum for Red

Longitudinal  
chromatic  
aberration

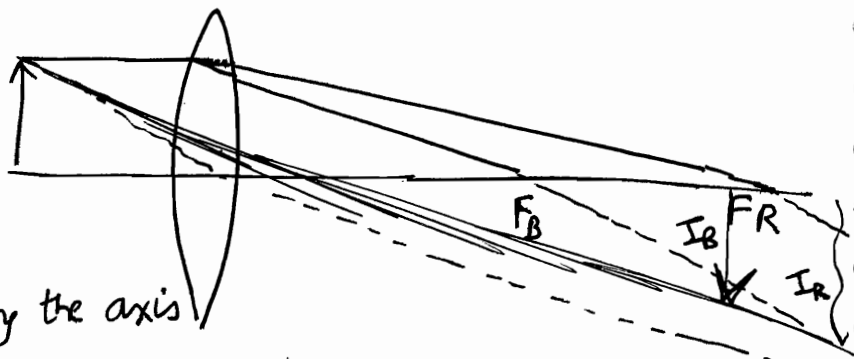

$I_R$  further than  $I_B$  i.e.  
spreading of image along the axis

⊛ Chromatic Aberration is determined by  $\left(\frac{df}{d\lambda}\right)$  and  $[F_R - F_B]$

Lateral chromatic aberration

$I_R$  is longer than  $I_B$  in height.

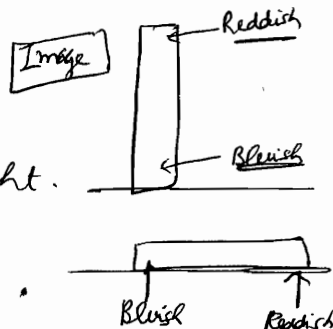

For achromatism,  $F_R - F_B = 0$  or  $\left(\frac{\Delta f}{\Delta \lambda}\right) = 0$

For a lens

$$F_R - F_B$$

$$\frac{1}{F_R} = (\mu_R - 1) \left[ \frac{1}{R_1} + \frac{1}{R_2} \right] \quad - (1)$$

$$\frac{1}{F_B} = (\mu_B - 1) \left[ \frac{1}{R_1} + \frac{1}{R_2} \right] \quad - (2)$$

$$\frac{1}{F_y} = (\mu_y - 1) \left[ \frac{1}{R_1} + \frac{1}{R_2} \right] \quad - (3)$$



$$\frac{1}{f_B} - \frac{1}{f_R} = (\mu_B - \mu_R) \left[ \frac{1}{R_1} + \frac{1}{R_2} \right]$$

$$\frac{1}{f_B} - \frac{1}{f_R} = \frac{(\mu_B - \mu_R)}{(\mu_y - 1)} \cdot \frac{1}{f_y}$$

$$\Rightarrow \frac{f_R - f_B}{f_B f_R} = \frac{(\mu_B - \mu_R)}{(\mu_y - 1)} \cdot \left( \frac{1}{f_y} \right) = \left( \frac{\omega}{f_y} \right)$$

$\omega$ : dispersive power of lens. =  $\left[ \frac{\mu_B - \mu_R}{\mu_y - 1} \right]$

$$f_B f_R \approx f_y^2$$

$\omega$ : +ve

$$\Rightarrow \frac{f_R - f_B}{f_y^2} = \frac{\omega}{f_y}$$

$$\Rightarrow \boxed{f_R - f_B = \omega f_y}$$

$$\mu_y \approx \frac{\mu_R + \mu_B}{2}$$

### Condition of Achromatism

For convex lens:  $f$  +ve

For concave lens:  $f$  -ve

1 lens: eyepiece

Other lens: objective

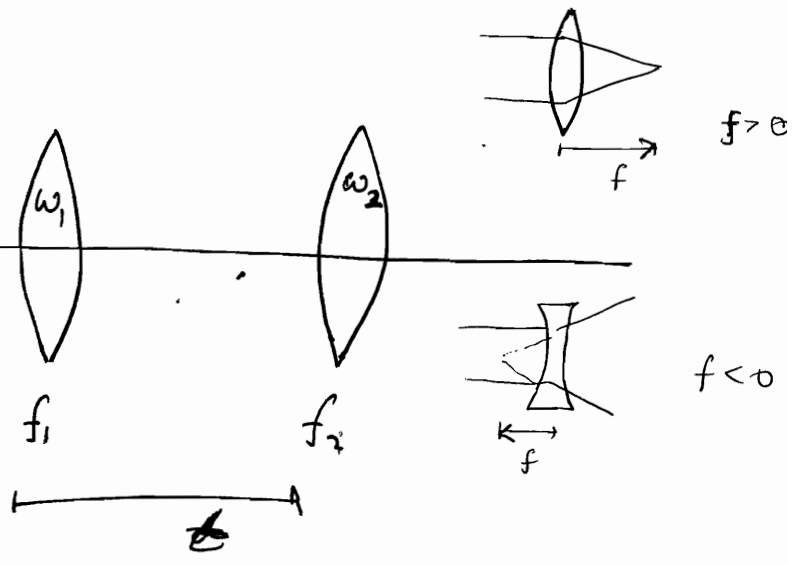

Resultant focal length should not vary with  $\lambda$ .

$$\text{Chromatic aberration} = f_R - f_B = \omega f$$

$$\boxed{\frac{1}{F} = \frac{1}{f_1} + \frac{1}{f_2} - \frac{t}{f_1 f_2}} \quad \left[ \text{Formula for Combined focal length} \right]$$

$$-\frac{dF}{F^2} = -\frac{df_1}{f_1^2} - \frac{df_2}{f_2^2} + t \left[ \frac{f_1 df_2 + f_2 df_1}{(f_1 f_2)^2} \right]$$

$\Rightarrow$  Now for achromatic,  $dF = 0$

$$\Rightarrow \frac{df_1}{f_1^2} + \frac{df_2}{f_2^2} = t \left[ \frac{f_1 df_2 + f_2 df_1}{(f_1 f_2)^2} \right]$$

$$\boxed{\begin{aligned} df_1 &= \omega_1 f_1 \\ df_2 &= \omega_2 f_2 \end{aligned}}$$

$$\Rightarrow \frac{\omega_1}{f_1} + \frac{\omega_2}{f_2} = t \left[ \frac{\omega_2 + \omega_1}{f_1 f_2} \right]$$

✓ सही जग  
होती !!

$$\Rightarrow \boxed{t = \left[ \frac{\omega_1 f_2 + \omega_2 f_1}{\omega_1 + \omega_2} \right]}$$

### 3 cases

$$\textcircled{1} \quad \omega_1 = \omega_2 \Rightarrow t = \left[ \frac{f_1 + f_2}{2} \right]$$

Used in Huygens eyepiece

$$\textcircled{2} \quad t=0 \Rightarrow \frac{\omega_1}{f_1} + \frac{\omega_2}{f_2} = 0$$

$$\text{ie.} \quad \frac{f_2}{f_1} = - \left( \frac{\omega_2}{\omega_1} \right) : \ominus \text{ve}$$

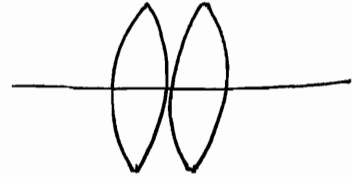

$\Rightarrow$  1 lens is convex, other is concave.

Such a system is called  
**ACHROMATIC DOUBLET.**

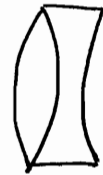

or



$$\left[ \begin{array}{l} \frac{1}{F} = \frac{1}{f_1} + \frac{1}{f_2} \\ \Rightarrow -\frac{dF}{F^2} = -\frac{df_1}{f_1^2} - \frac{df_2}{f_2^2} \\ \Rightarrow \frac{\omega_1}{f_1} + \frac{\omega_2}{f_2} = 0 \end{array} \right]$$

$$\textcircled{3} \quad \omega_1 = \omega_2 \quad \& \quad t=0$$

$$\frac{1}{f_1} + \frac{1}{f_2} = 0 \Rightarrow \frac{1}{F} = 0 \Rightarrow F = \infty$$

Optical system behaves as Plane Glass Plate.

Q6)

$$\frac{1}{F} = \frac{1}{f_1} - \frac{1}{f_2} \quad \text{--- (1)}$$

$$\frac{\omega_1}{f_1} = -\frac{\omega_2}{f_2} \quad \text{--- (2)}$$

$$\omega_1 = \frac{n_B - n_R}{\frac{n_B + n_R}{2} - 1}$$

Spherical Aberration is due to large size of lens [large aperture size]  
Periphery Rays ~~are~~ Marginal Rays focus at different points than Paraxial Rays

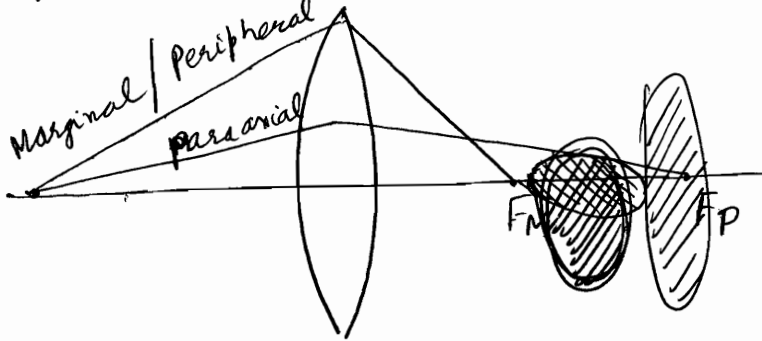

Disk shaped Image is formed.

Spherical Aberration cannot be eliminated. It will also be present. We can at max minimize it.

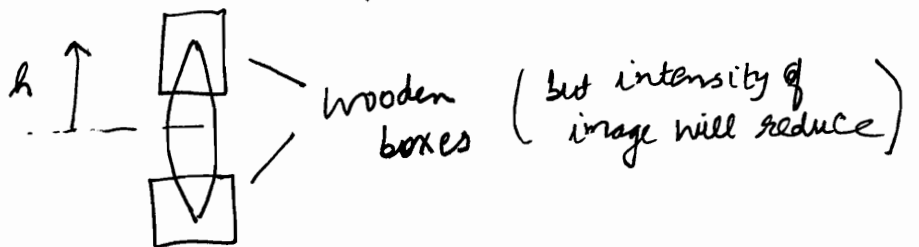

Spherical Aberration can be mathematically described

as  $\frac{h^2}{f} \phi(k, \mu)$

k: shape factor  $\left(\frac{R_1}{R_2}\right)$

if  $\mu = 1.5$ ,  $\phi_{\min}(k, \mu)$  for  $k = -\frac{1}{6}$

→ for  $k = -\frac{1}{6}$

To minimize spherical Aberration,

$$R_2 = -6R_1$$

minimize  $\frac{h^2}{f} \phi(k, \mu)$

sort of like this 

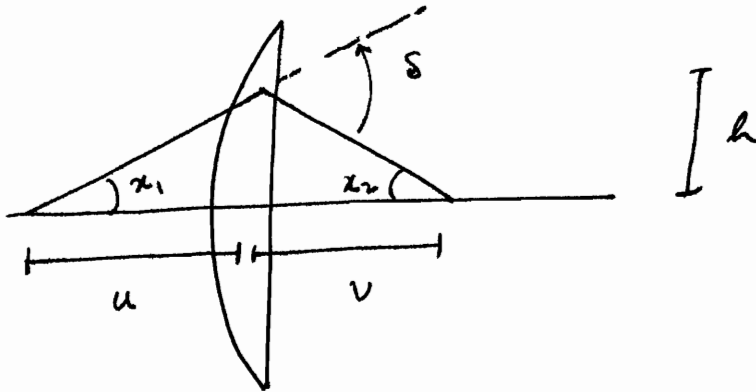

$$\delta_s = \alpha_1 + \alpha_2$$

$$= \frac{h}{v} + \frac{h}{u} = \left( \frac{h}{f} \right)$$

distance between lenses when S.A. is minimum

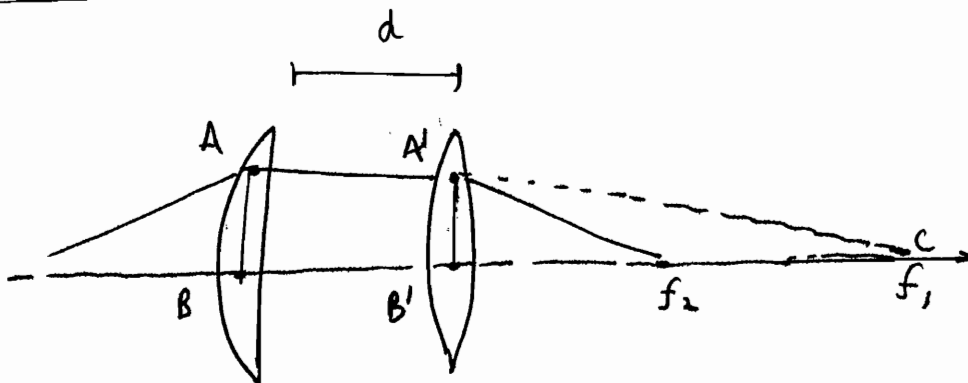

S.A. minimum

$$\delta_1 = \delta_2 \checkmark$$

$$\Rightarrow \frac{h_1}{f_1} = \frac{h_2}{f_2} \checkmark$$

$$\Rightarrow \left( \frac{h_1}{h_2} \right) = \left( \frac{f_1}{f_2} \right) \checkmark$$

$$\frac{h_1}{h_2} = \left( \frac{f_1}{f_1 - d} \right)$$

$$\Rightarrow \boxed{f_2 = f_1 - d}$$

$$\Rightarrow \boxed{d = f_1 \sim f_2}$$

# Mirror Formula from Fermat's Principle

0

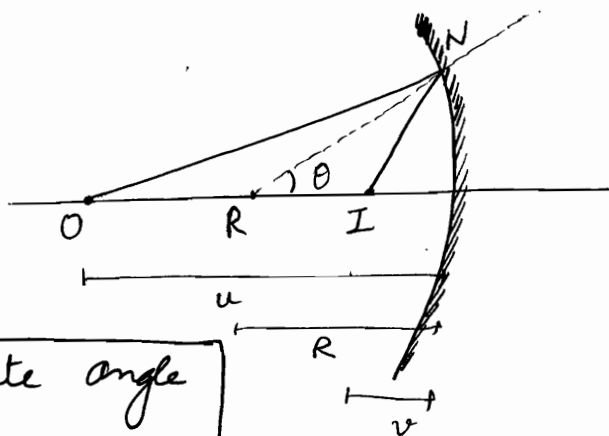

Choose the acute angle as  $\theta$

$$ds = 0 \quad - \quad (1)$$

$$S = \mu_1 [ON + NI]$$

$$ON = \sqrt{(u-R)^2 + R^2 + 2R(u-R) \cos \theta}$$

$$NI = \sqrt{(R-v)^2 + R^2 - 2R(R-v) \cos \theta}$$

$\Rightarrow$  Applying (1), we get

$$\frac{1}{2} \lambda_1^{\frac{1}{2}} \cdot 2R(u-R)(-\sin \theta) = \frac{1}{2} \lambda_2^{\frac{1}{2}} \cdot 2R(R-v)(-\sin \theta)$$

$$\Rightarrow \frac{u-R}{\sqrt{\lambda_1}} = \frac{R-v}{\sqrt{\lambda_2}}$$

Put  $\cos \theta = 1$

$$\Rightarrow \frac{u-R}{u} = \frac{R-v}{v}$$

$$\Rightarrow 1 - \frac{R}{u} = \frac{R}{v} - 1 \quad \Rightarrow$$

$$\boxed{\frac{2}{R} = \frac{1}{v} + \frac{1}{u}}$$

# Spherical Aberration

- 3 methods to minimize it
- definition of  $S$

Point object forms disk shaped image due to large aperture size of optical system.

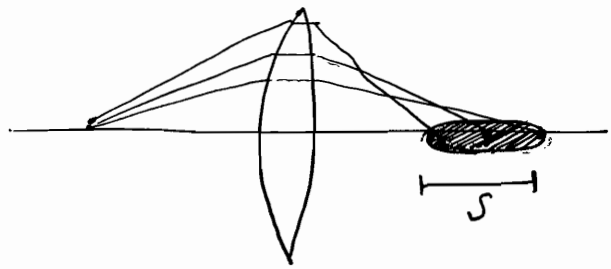

lens can be divided into various zones and different rays from different zones have different focal points. Marginal rays will have small focal lengths.

Spherical Aberration,  $S = \frac{h^2}{f} \phi(k, n)$

where  $\phi = \left( \frac{R_1}{R_2} \right)$   $n$ : refractive index of lens.  
SHAPE FACTOR

Spherical Aberration cannot be completely eliminated but can be minimized by using  $(k, n)$  such that  $\phi(k, n)$  is minimum.

① It comes out to be minimum for  $n = 1.5$ ,  $k = -\frac{1}{6} = \frac{R_1}{R_2}$

Also  $S$  can be minimized by putting stops eg. wooden blocks

②

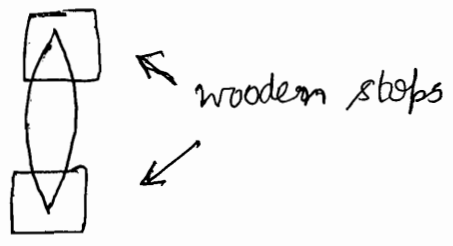

3 ways to minimize  $S$

# Minimization of Spherical Aberration by putting another lens

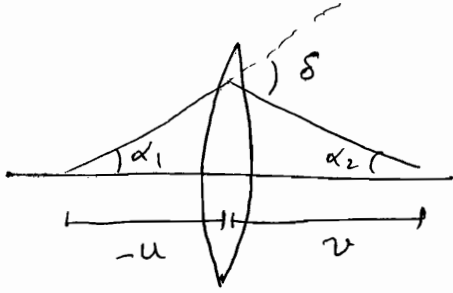

For a lens, deviation  $\delta$ , is given by

$$\delta = \alpha_1 + \alpha_2$$

$$= -\frac{h}{u} + \frac{h}{v} = \frac{h}{f}$$

When a beam of light passes through a system of two lenses placed coaxially at distance  $d$  apart, the ~~refraction~~ spherical aberration is minimum when there is an equal deviation at both lenses

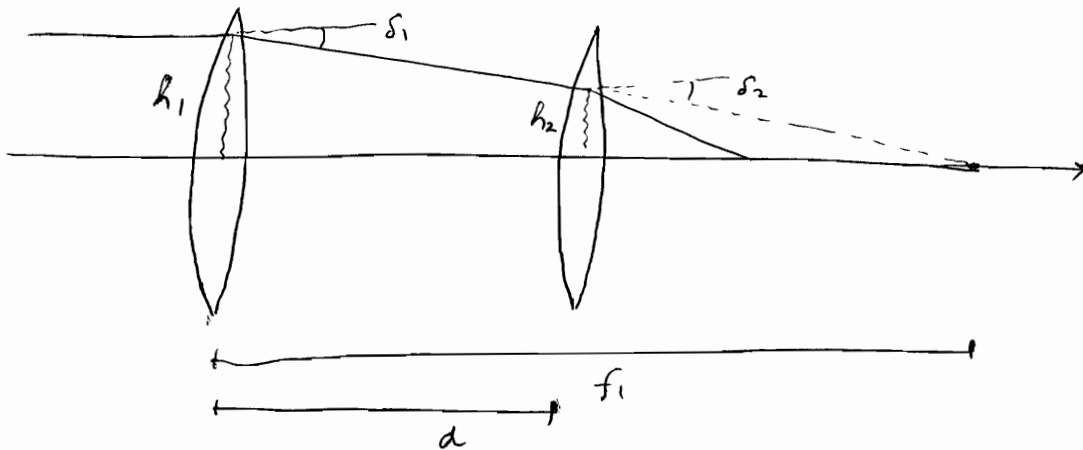

Now from similarity of  $\Delta s$ ,

$$\frac{h_1}{f_1} = \frac{h_2}{f_1 - d} \quad - (1)$$

and  $\delta_1 = \delta_2$  (for minimum aberration)

$$\Rightarrow \frac{h_1}{f_1} = \frac{h_2}{f_2} \quad - (2)$$

$$\Rightarrow \boxed{f_1 - f_2 = d}$$

3



# OPTICS (6)

- 10/12/11
- ① Translation Matrix
  - ② Refraction Matrix
  - ③ Refraction through spherical surface formula
  - ④ Optical System
  - ⑤ Lens Maker
  - ⑥ 2-Lens System

## Matrix Method in Paraxial Optics

⑦ Unit Plane & Nodal Plane

Any point on a ray is expressed by 2 variables :  
 [direction cosine, height]  $\Leftrightarrow$  [ $\lambda$ ,  $y$ ]

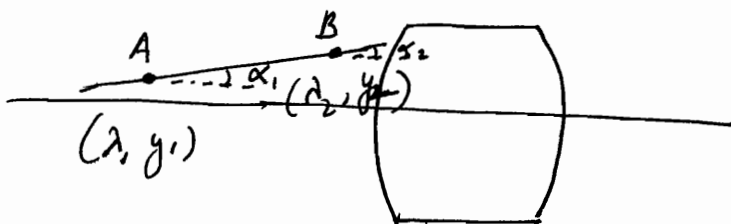

$\lambda$  : directional cosine of ray

$$= (n * \alpha)$$

↑  
refractive index

↑  
angle made with horizontal

def<sup>n</sup> of  $\lambda$

$$A (n_1, \alpha_1, y_1)$$

$$B (n_2, \alpha_2, y_2)$$

Coordinates are represented as a column matrix

$$\begin{bmatrix} \lambda \\ y \end{bmatrix}$$

For any ray, 2 operations :- translation  
refraction

### Translation

Let

A : starting point

B : reaching point

ray travels through horizontal distance 'd' and reaches B.

In translation, no. medium change  $\Rightarrow n_1 = n_2$

Since no refraction, angle with horizontal same at both points i.e.  $\lambda_1 = \lambda_2$

$$\Rightarrow \lambda_2 = 1 \cdot \lambda_1 + 0 \cdot y_1$$

$$\frac{y_2 - y_1}{D} = \tan \alpha_1$$

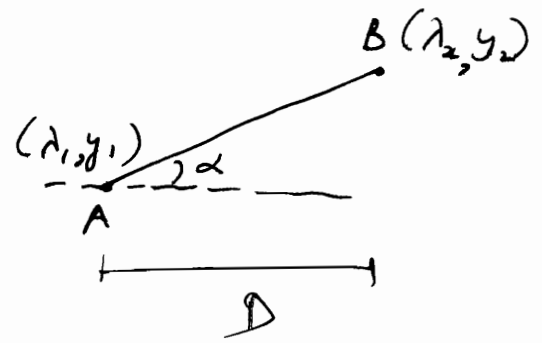

$$\Rightarrow y_2 = D \tan \alpha_1 + y_1$$

$$\Rightarrow y_2 = D \alpha_1 + y_1$$

$$\Rightarrow y_2 = \left(\frac{D}{n_1}\right) n_1 \alpha_1 + y_1 = \left(\frac{D}{n_1}\right) \lambda_1 + 1 \cdot y_1$$

$$\Rightarrow \begin{bmatrix} \lambda_2 \\ y_2 \end{bmatrix} = \begin{bmatrix} 1 & 0 \\ \left(\frac{D}{n_1}\right) & 1 \end{bmatrix} \begin{bmatrix} \lambda_1 \\ y_1 \end{bmatrix}$$

↑  
Translation Matrix T

$$\det [T] = 1$$

Refraction

[Note that if we consider refraction at a straight line boundary, that would be a very specific case of  $R = \infty$ . We need to deal with a general case....]

Let us take spherical refracting surface

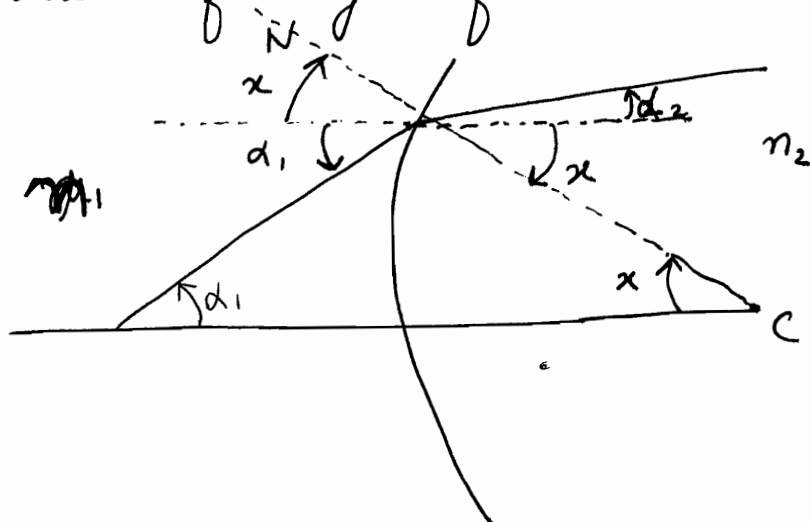

$$\angle i = \alpha + \alpha_1$$

$$\angle r = \alpha + \alpha_2$$

Let us consider 2 points just before & just after refraction

s.t.  $y_2 = y_1$

i.e.  $y_2 = 0 \cdot \lambda_1 + 1 \cdot y_1$

Snell's law:  $n_1 \sin i = n_2 \sin r$

$\Rightarrow n_1 \angle i = n_2 \angle r$

$\Rightarrow n_1 (\alpha_1 + x) = n_2 (\alpha_2 + x)$

$\Rightarrow n_2 d_2 = n_1 d_1 + (n_1 - n_2) x$

$\sin x = \left( \frac{y}{R} \right) \Rightarrow x = \left( \frac{y}{R} \right)$

$\Rightarrow n_2 d_2 = n_1 d_1 - (n_2 - n_1) \frac{y_1}{R}$

$\Rightarrow \lambda_2 = \lambda_1 - \left[ \frac{n_2 - n_1}{R} \right] y_1$

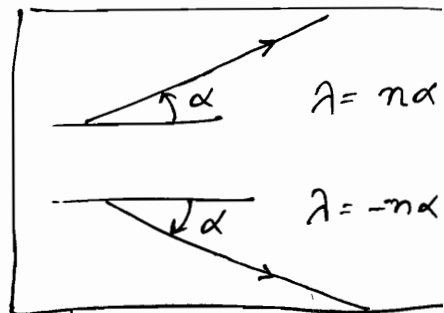

$y$  बढ़ेगा तो  $+\alpha$   
 $y$  घटेगा तो  $-\alpha$

$P \Rightarrow$  Power of spherical refracting surface =  $\left[ \frac{n_2 - n_1}{R} \right]$

$\Rightarrow \lambda_2 = 1 \cdot \lambda_1 - P \cdot y_1$

$\Rightarrow \begin{bmatrix} \lambda_2 \\ y_2 \end{bmatrix} = \begin{bmatrix} 1 & -P \\ 0 & 1 \end{bmatrix} \begin{bmatrix} \lambda_1 \\ y_1 \end{bmatrix}$

Refraction Matrix : R

$\det [R] = 1$

convex surface  $\rightarrow \oplus$ ve  $\rightarrow (+)$

concave surface  $\rightarrow \ominus$ ve  $\rightarrow (-)$

depending on sign of R

Now if we apply

$\begin{bmatrix} 1 & 0 \\ \frac{v_2}{n_2} & 0 \end{bmatrix} \& R \& \begin{bmatrix} 1 & 0 \\ -\frac{u_1}{n_1} & 1 \end{bmatrix}$

we get

$\frac{n_2}{v} - \frac{n_1}{u} = \left( \frac{n_2 - n_1}{R} \right)$

by using point object  $\rightarrow$  point image

# Optical System

$$\begin{bmatrix} a & b \\ c & d \end{bmatrix}$$

matrix को आरे  
सारे formula paper में  
derive करो... कोई भी  
एर में से  
standard result  
नहीं है!!

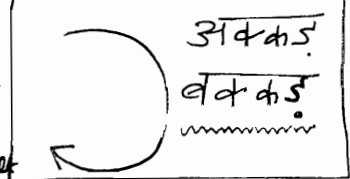

OPTICAL SYSTEM

System Matrix

$$S = \begin{bmatrix} b & -a \\ -d & c \end{bmatrix}$$

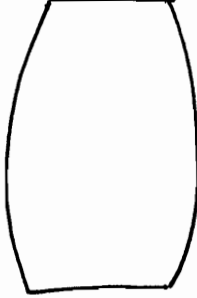

$$\det[S] = bc - ad = 1$$

→ Combination of  
translation  
and refraction

$$\begin{aligned} \det[AB] &= \det[A] \det[B] \\ &= 1 \cdot 1 \\ &= 1 \end{aligned}$$

In general, an optical system  
made up of series of lenses  
can be characterized by the  
refraction & translation matrices.

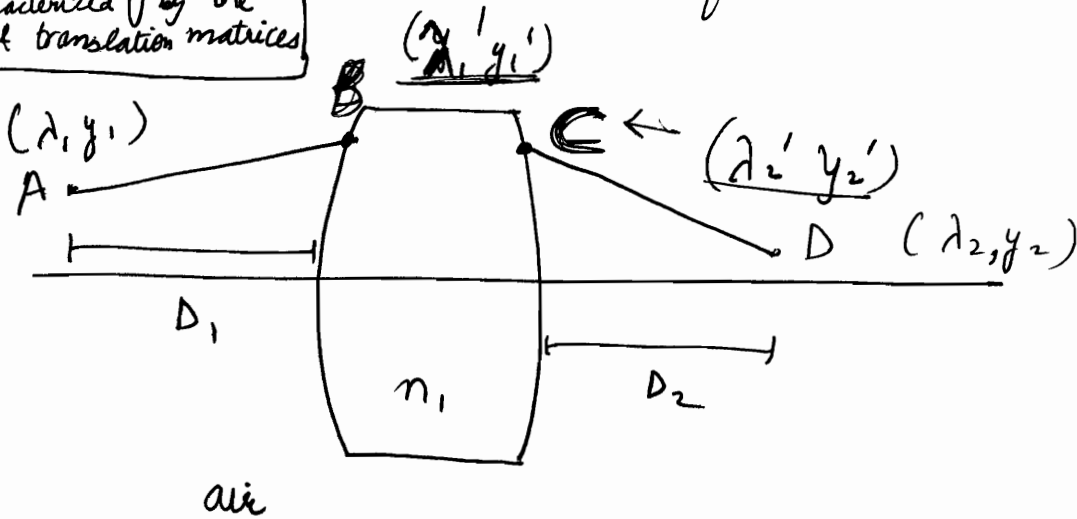

If parallel ray :  $\lambda_1 = 0$

⊛ If not air,  
then replace  $D_1$  by  
 $(\frac{D_1}{n_1})$  and  $D_2$  by  $(\frac{D_2}{n_1})$

$$\begin{bmatrix} \lambda_1' \\ y_1' \end{bmatrix} = \begin{bmatrix} 1 & 0 \\ D_1 & 1 \end{bmatrix} \begin{bmatrix} \lambda_1 \\ y_1 \end{bmatrix}$$

$$\begin{bmatrix} \lambda_2' \\ y_2' \end{bmatrix} = \begin{bmatrix} b & -a \\ -d & c \end{bmatrix} \begin{bmatrix} \lambda_1' \\ y_1' \end{bmatrix}$$

$$\begin{bmatrix} \lambda_2 \\ y_2 \end{bmatrix} = \begin{bmatrix} 1 & 0 \\ D_2 & 1 \end{bmatrix} \begin{bmatrix} \lambda_2' \\ y_2' \end{bmatrix}$$

do not  
write the  
opposite  
order

$$\Rightarrow \begin{bmatrix} \lambda_2 \\ y_2 \end{bmatrix} = \begin{bmatrix} 1 & 0 \\ D_2 & 1 \end{bmatrix} \begin{bmatrix} b & -a \\ -d & c \end{bmatrix} \begin{bmatrix} 1 & 0 \\ D_1 & 1 \end{bmatrix} \begin{bmatrix} \lambda_1 \\ y_1 \end{bmatrix}$$

translation      optical system      translation

$$\begin{bmatrix} \lambda_2 \\ y_2 \end{bmatrix} = \begin{bmatrix} b & -a \\ D_2 b - d & -D_2 a + c \end{bmatrix} \begin{bmatrix} 1 & 0 \\ D_1 & 1 \end{bmatrix} \begin{bmatrix} \lambda_1 \\ y_1 \end{bmatrix}$$

$$\Rightarrow \begin{bmatrix} \lambda_2 \\ y_2 \end{bmatrix} = \begin{bmatrix} b - aD_1 & -a \\ D_2 b - d - D_1 D_2 a + cD_1 & -D_2 a + c \end{bmatrix} \begin{bmatrix} \lambda_1 \\ y_1 \end{bmatrix}$$

• Determinant of system matrix has to be 1.

• Ideal optical system is free from all aberrations i.e. Point image of point object

i.e. if  $y_1 = 0 \Rightarrow y_2 = 0 \quad \forall \lambda_1$

$$\Rightarrow y_2 = (D_2 b - d - D_1 D_2 a + cD_1) \lambda_1 + (-D_2 a + c) y_1$$

$$\Rightarrow \boxed{D_2 b - d - D_1 D_2 a + cD_1 = 0} \quad \checkmark$$

★ Use of  $+D_1$  and  $+D_2$  is perfect

•  $\frac{y_2}{y_1}$  is called Magnification  $M$

$$\boxed{M = [c - aD_2]} \quad \checkmark$$

• since  $\det [S^*] = 1$

$$\Rightarrow \det [k] = 1 \quad \text{where } k \text{ is } \begin{bmatrix} b - aD_1 & -a \\ 0 & -D_2 a + c \end{bmatrix}$$

$$\Rightarrow (b - aD_1)(-D_2 a + c) = 1$$

$$\Rightarrow \boxed{(b - aD_1) = \frac{1}{c - aD_2} = \left(\frac{1}{M}\right)} \quad \checkmark \quad \checkmark$$

① Unit Planes or Nodal Planes are planes on both sides of system where magnification is 1.

$$\text{Also } bD_2 - d - D_1D_2a + cD_1 = 0$$

$$\Rightarrow \frac{b}{D_1} - \frac{d}{D_1D_2} - a + \frac{c}{D_2} = 0$$

$$\Rightarrow \boxed{\frac{b}{D_1} + \frac{c}{D_2} = a + \frac{d}{D_1D_2}}$$

lensmaker's Formula

Sign Convention

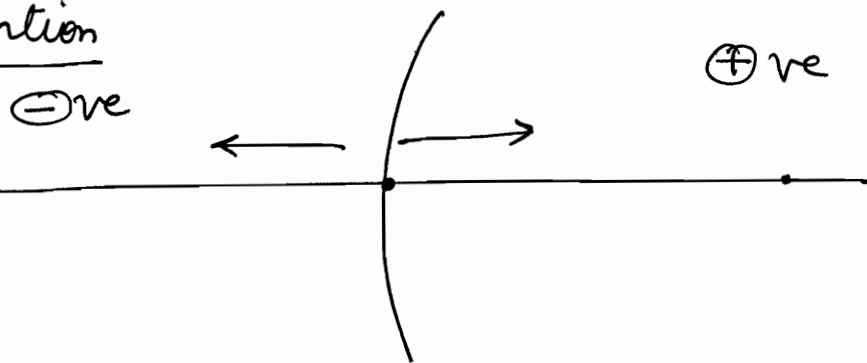

Thick lens

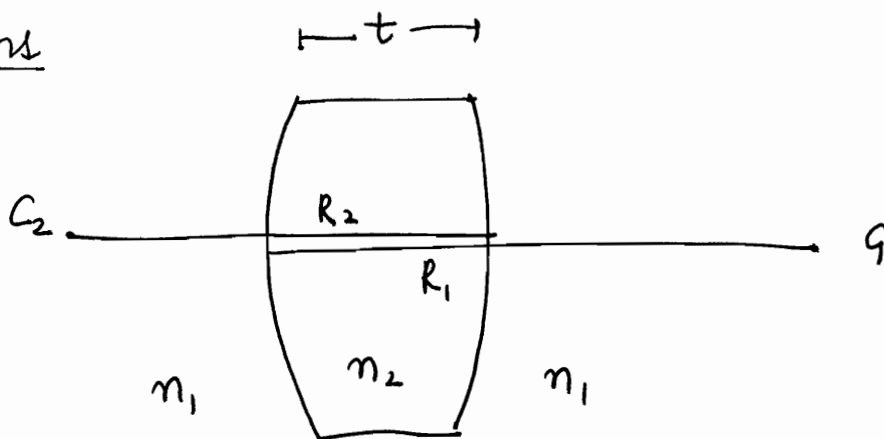

$$\begin{bmatrix} \lambda_2' \\ y_2' \end{bmatrix} = \begin{matrix} \text{spherical surface} \\ \begin{bmatrix} 1 & -P_2 \\ 0 & 1 \end{bmatrix} \end{matrix} \begin{matrix} \text{Translation} \\ \begin{bmatrix} 1 & 0 \\ \frac{t}{n_2} & 1 \end{bmatrix} \end{matrix} \begin{matrix} \text{spherical surface} \\ \begin{bmatrix} 1 & -P_1 \\ 0 & 1 \end{bmatrix} \end{matrix} \begin{bmatrix} \lambda_1' \\ y_1' \end{bmatrix}$$

In matrix, last operation  $\uparrow$  <sup>rt</sup>

# Thin lens

$$\begin{bmatrix} \lambda_2' \\ y_2' \end{bmatrix} = \begin{bmatrix} 1 & -P_2 \\ 0 & 1 \end{bmatrix} \begin{bmatrix} 1 & 0 \\ 0 & 1 \end{bmatrix} \begin{bmatrix} 1 & -P_1 \\ 0 & 1 \end{bmatrix} \begin{bmatrix} \lambda_1' \\ y_1' \end{bmatrix} = \begin{bmatrix} 1 & -(P_1+P_2) \\ 0 & 1 \end{bmatrix} \begin{bmatrix} \lambda_1' \\ y_1' \end{bmatrix}$$

★ एक "2-1" दूसरा "1-2" है !!  
 ↓  
 $P_{eff} = (n_2 - n_1) \left[ \frac{1}{R_1} + \frac{1}{R_2} \right]$

$\Rightarrow P_{eff} = P_1 + P_2$

$P_1 = \frac{n_2 - n_1}{R_1}$        $P_2 = \frac{n_1 - n_2}{R_2} = -\frac{n_2 - n_1}{R_2}$        $\Rightarrow P_{eff} = (n_2 - n_1) \left[ \frac{1}{R_1} + \frac{1}{R_2} \right]$



From the matrix,  $b = 1$        $c = 1$        $d = 0$        $a = (P_1 + P_2)$

We also know,  $\frac{b}{D_1} + \frac{c}{D_2} = a + \frac{d}{D_1 D_2}$

$\Rightarrow \frac{1}{D_1} + \frac{1}{D_2} = P_1 + P_2 = (n_2 - n_1) \left[ \frac{1}{R_1} + \frac{1}{R_2} \right]$

if  $D_1 = \infty \Rightarrow D_2 = f$  ✓ ★ Note that for general case, replace  $D_1$  and  $D_2$  by  $-(D_1/n_1)$  and  $(D_2/n_2)$  ...

$\Rightarrow \frac{1}{\infty} + \frac{1}{f} = \frac{1}{f} = (n_2 - n_1) \left[ \frac{1}{R_1} + \frac{1}{R_2} \right]$  lens makers Formula for  $n_1 = 1$

System Matrix

For convex lens,  $\begin{bmatrix} \lambda_2' \\ y_2' \end{bmatrix} = \begin{bmatrix} 1 & (-1/f) \\ 0 & 1 \end{bmatrix} \begin{bmatrix} \lambda_1' \\ y_1' \end{bmatrix}$

thin lens:  $t = 0$

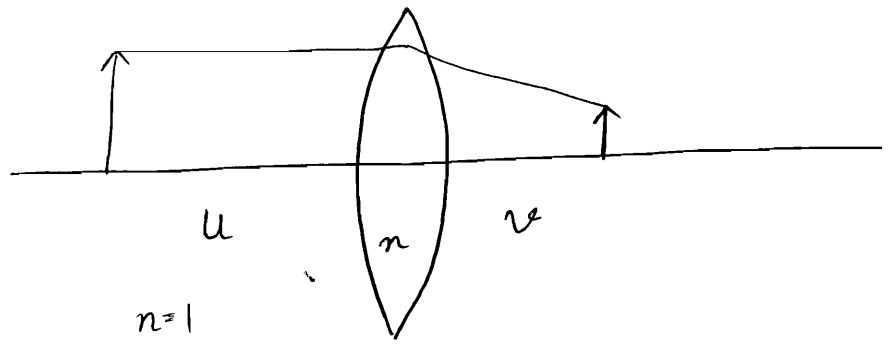

$S = \begin{bmatrix} 1 & -P_2 \\ 0 & 1 \end{bmatrix} \begin{bmatrix} 1 & -P_1 \\ 0 & 1 \end{bmatrix} = \begin{bmatrix} 1 & -P_{eff} \\ 0 & 1 \end{bmatrix}$

$P_{eff} = P_1 + P_2$

$$P_1 = \frac{n-1}{R_1} \quad P_2 = \frac{1-n}{+R_2} = -\left(\frac{n-1}{R_2}\right) \quad P_{\text{eff}} = (n-1) \left[ \frac{1}{R_1} + \frac{1}{R_2} \right]$$

$$\begin{aligned} \begin{bmatrix} \lambda_2 \\ y_2 \end{bmatrix} &= \begin{bmatrix} 1 & 0 \\ v & 1 \end{bmatrix} \begin{bmatrix} 1 & -P_{\text{eff}} \\ 0 & 1 \end{bmatrix} \begin{bmatrix} 1 & 0 \\ u & 1 \end{bmatrix} \begin{bmatrix} \lambda_1 \\ y_1 \end{bmatrix} \\ &= \begin{bmatrix} 1 & -P_{\text{eff}} \\ v & -v P_{\text{eff}} + 1 \end{bmatrix} \begin{bmatrix} 1 & 0 \\ u & 1 \end{bmatrix} \begin{bmatrix} \lambda_1 \\ y_1 \end{bmatrix} \end{aligned}$$

$$\Rightarrow \begin{bmatrix} \lambda_2 \\ y_2 \end{bmatrix} = \begin{bmatrix} (1 - u P_{\text{eff}}) & (-P_{\text{eff}}) \\ (v - uv P_{\text{eff}} + u) & (1 - v P_{\text{eff}}) \end{bmatrix} \begin{bmatrix} \lambda_1 \\ y_1 \end{bmatrix}$$

$$y_2 = (u + v - uv P_{\text{eff}}) \lambda_1 + (1 - v P_{\text{eff}}) y_1$$

For ideal optical system, point image of point source

i.e. if  $y_1 = 0 \Rightarrow y_2 = 0$

$$\Rightarrow u + v - uv P_{\text{eff}} = 0$$

$$\Rightarrow u + v = uv P_{\text{eff}}$$

$$\Rightarrow \frac{1}{v} + \frac{1}{u} = (n-1) \left( \frac{1}{R_1} + \frac{1}{R_2} \right) = \frac{1}{f}$$

Since  $u$  is negative

$$\Rightarrow \boxed{\frac{1}{v} - \frac{1}{u} = (n-1) \left( \frac{1}{R_1} + \frac{1}{R_2} \right) = \frac{1}{f}} \quad \checkmark$$



## WAVES TUTORIAL SHEET: 7A

### Damped and Forced Oscillations

1. Calculate the rate of energy dissipation by a damped harmonic oscillator, in the weak damping limit With  $w_0 \tau \gg 1$ , so that  $\omega \cong \omega_0$ . Symbols have their usual meanings. (1988)  $\frac{1}{26}$
2. Write down the differential equation for a damped simple harmonic oscillator. Solve it and discuss the characteristics of dead - beat motion. (1990)
3. Give a mathematical analysis of forced vibration and hence explain the phenomenon of amplitude resonance. (1992)
4. Show that for forced oscillations amplitude resonance and energy resonance do not occur at the same frequency. (1995)
5. Write the equation of motion for an oscillator driven by a simple harmonically varying force. Obtain the condition for maximum energy transfer to the oscillator. (1996)
6. The amplitude of a damped Oscillator of frequency 300 Hz reduces to one - tenth of its initial amplitude after 3000 Oscillations. Calculate the damping constant and the time in which its energy will reduce to one - tenth of its initial energy. (1997) 1500 osc.
7. What are damped oscillations? Obtain the differential equation for damped oscillations and write its possible solution. Explain, with corresponding sketches, when there can be very heavy damping, critical damping and weak damping. (1999)  
*A resistive force - b v proportional to the*
8. An ideal massless spring of force constant k has a mass m attached to one of its ends, the other end being fixed to a rigid support. The spring is horizontal and the mass moves on a horizontal floor. Velocity v acts on the mass. Assuming the damping to be light, obtain the frequency of oscillation. When  $m = 0.1$  kg and  $k = 10$  n/m, it is found that the frequency of oscillation is  $\sqrt{1/2}$  times the frequency in the absence of damping. Calculate the value of constant b. (2003)
9. Write down the equation of motion for a damped harmonic oscillator assuming the damping force proportional to the velocity of the particle. Obtain the general solution for its displacement as a function of time. Discuss the cases of over damping, under damping and critical damping. (2004)
10. In the steady state forced vibration a point particle of mass 'm' moves under the influence of an external force  $(F \sin pt) \hat{i}$  in addition to the restoring force  $-(kx) \hat{i}$  and damping force  $-(\beta \dot{x}) \hat{i}$ . Show that (i) the amplitude is maximum when  $p = \sqrt{\omega^2 - 2b^2}$ , where  $k/m = \omega^2$  and (ii) the value of the maximum amplitude is  $\frac{f}{2b\sqrt{\omega^2 - b^2}}$ . What do you mean by the sharpness of resonance? (2006)

**TUTORIAL SHEET: 7B**

**Beats, Stationary waves, Phase & Group velocity, Huygen 's Principle**

1. The phase velocity of surface waves of wave length  $\lambda$  is  $V_p = \left( \frac{2\pi T}{\lambda \rho} + \frac{g\lambda}{2\pi} \right)^{1/2}$  where T is the surface tension and  $\rho$  the density of the liquid and g is acceleration due to gravity. Find the group velocity and express it in terms of the phase velocity. For which wavelength is the phase velocity a minimum? (1991)

2. Explain the laws of refraction of light on the basis of Huygens principle. (1991)

3. The refractive indices of a material of wavelengths 5090 Å, 5340 Å and 5890 Å are equal to 1.647, 1.640 and 1.630 respectively. Estimate the phase and group velocities of light near  $\lambda = 5340 \text{ Å}$ . (1993)

4. Distinguish between phase velocity and group velocity. Calling group velocity  $V_g$  and phase velocity  $V_p$  in a medium of refractive index n, establish the relation

$$V_g = V_p \left( 1 + \frac{\lambda}{n} \frac{dn}{d\lambda} \right) \text{ where } \lambda \text{ refers to the wavelength of the related light in vacuum. (1994)}$$

5. Certain string has a linear mass density of 0.25 kg/m and stretched with a tension of 25 N. One end is given a sinusoidal motion, its frequency 5 Hz and amplitude 0.01 metre. If at  $t=0$ , the end has zero displacements and is moving along the positive y direction, derive the wave speed, the wave length and the wave equation of the wave in the string. (2001)

6. The phase velocity in a material is  $\sqrt{g/k}$  where k is the propagation constant. Prove that the group velocity will be half of the phase velocity. (2001)

A wave is represented by  $\Psi_1 = 10 \cos(5x + 25t)$ . Find wave length  $\lambda$ , velocity v, frequency f and the direction of propagation. If it interferes with another wave given by  $\Psi_2 = 20 \cos(5x + 25t + \pi/3)$ , find the amplitude and the phase of the resultant wave (2002)

8. The phase velocity of the surface wave in a liquid of surface tension T and density  $\rho$  is given by

$$\lambda \text{ is } V_p = \left( \frac{2\pi T}{\lambda \rho} + \frac{g\lambda}{2\pi} \right)^{1/2} \text{ Show that the group velocity } V_g \text{ of the surface wave is given by}$$

9. Two transverse harmonic waves, each of amplitude 5mm, wave length 1 m and speed 3m/s are traveling in opposite directions along a stretched string fixed at both ends. Obtain an expression for the standing wave produced. Locate the positions of nodes and antinodes. (2003)

10. A siren of frequency 900 Hz is going towards a wall away from an observer at a speed of 10 m/sec. Determine

- (i) Frequency of sound directly heard from the siren.
- (ii) Frequency of sound reflected from the wall.
- (iii) Number of beats per second heard by the observer. (velocity of sound = 330 m/sec).

(2004)

11. For a transverse sinusoidal wave of wavelength  $\lambda$  propagating along negative x direction through a string fixed at a point, show that the nodes are located at  $x = 0, \lambda/2, \lambda, 3\lambda/2, \dots$  while the kinetic energy/unit length at the antinodes is given by

$$E = 2\rho A^2 \omega^2 \cos^2 \omega t$$

Where  $\rho$ , A and  $\omega$  are the mass density/unit length, amplitude of transverse displacement and angular frequency of the wave, respectively. (2005)

12. Establish the relationship between the phase velocity  $V_p$  and the group velocity  $V_g$  of waves. Under physical conditions  $V_g < V_p$  and  $V_g > V_p$  can be possible? (2007)

(2007)

13. For stationary waves on a string whose ends are fixed, show that the energy density is maximum at antinodes and minimum at nodes. (2009)

14. In the propagation of longitudinal waves in a fluid contained in an infinitely long tube of cross-section A, show that

$$\rho = \rho_0 \left( 1 - \frac{\partial \xi}{\partial x} \right)$$

Where,  $\rho_0$  = equilibrium density

$\rho$  = density of the fluid in the disturbed state

$$\frac{d\xi}{dx} = \text{Volume Strain and } \left| \frac{\partial \xi}{\partial x} \right| \ll 1$$

(2010)

(2)

## TUTORIAL SHEET: 8

### Geometrical Optics

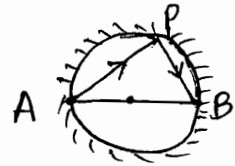

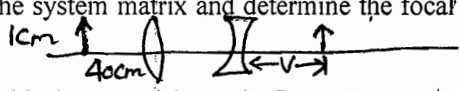
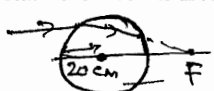
1. A ray of light starts from point A and after reflection from the inner surface of sphere reaches to diametrically opposite point B. Calculate the length of a hypothetical path APB and using Fermat's principle, find the actual path of length. Is the path minimum? (Ans. 2 dia, No)
2. In figure, P is a point source of light. If the distance of P from the center O of the spherical reflecting surface is  $0.8R$  and if the light ray starting from P and after being reflected at reaches at point Q, Show by Fermat's principle;  $\cos\theta/2=3/4$ .  $0.8R$
3. Consider a lens of thickness 1cm, made of a material of refractive index 1.5, placed in air (refractive index of air=1). Let the radii of curvatures of the two surface be +4cm and -4cm (negative sign corresponds to a concave surface). Obtain the system matrix and determine the focal length and the position of unit points and nodal points. 
4. Consider a system of two thin lenses as shown in figure For a 1cm tall object at a distance of 40cm from the convex lens, calculate the position and size of the image. Ans.:  $v=-14.5\text{cm}$ ,  $1/2.2\text{cm}$
5. Consider a sphere of radius 20cm of  $\mu=1.6$ . Find the position of paraxial focal point 
6. An achromatic doublet of focal length 20cm is to be made by placing a convex lens of borosilicate crown glass in contact with a diverging lens of dense flint glass. Assuming  $n_r = 1.51462$ ,  $n_b = 1.52264$ ,  $n_r' = 1.61216$ ,  $n_b' = 1.62901$ , calculate the focal length of each lens; here the unprimed and primed quantities refer to crown and flint glass respectively. Ans.  $F=8.61\text{cm}$ ,  $f_1=-15.1\text{cm}$
7. A lens with spherical surfaces and aperture of diameter 6cm shows spherical aberration of 1.8 cm. If the central portion of diameter 2cm alone is used, deduce the aberration. (Ans.: 0.2cm).
8. The spherical aberration of a lens is given by  $x = h^2/f \Phi$  is a constant. Compare the aberration in the following three cases:
  - (i) When central zone  $h=0$  to 5 mm is used.
  - (ii) When peripheral zone  $h=10$  mm to 12mm is used.
  - (iii) When the whole lens  $h=0$  to 12mm is used. (Ans. 25:44:144)
9. State Fermat's principle. Apply it to get the laws of reflection from a plane surface. (2002)
10. Two thin convex lenses of focal length 0.2m and 0.1m are located 0.1m apart on the axis of symmetry. An object of height 0.01m is placed at a distance of 0.2m from the first lens. Find by the matrix method, the position and the height of image. (2003)
11. Show that the ratio of the focal length of the two lenses in an achromatic doublet is given by  $f_1/f_2 = -w_1/w_2$ , where  $w_1$  and  $w_2$  are the dispersive powers of the lenses of focal length  $f_1$  and  $f_2$  respectively.
12. A thin converging lens and a thin diverging lens are placed coaxially at a distance of 5cm. If the focal length of each lens is 10cm, find for the combination (i) the focal length (ii) the power (iii) the position of the principal point. (2004)
13. What do you understand by paraxial rays? Show that the effect of translation of a paraxial ray while travelling along a homogeneous medium is represented by a  $2 \times 2$  matrix if the ray is initially defined by a  $2 \times 1$  matrix. (2005)
14. Derive Snell's law of refraction index related to the velocity of light? Light of wavelength 600 nanometer (in vacuum) enters a glass slab of refractive index 1.5. What are the values of wavelength, frequency and velocity of light in glass? (2006)

[ Velocity of light in vacuum =  $3 \times 10^8 \text{ ms}^{-1}$  ]

15. Derive the condition for achromatism of two thin lenses separated by a finite distance and made up of same material. (2009)

$$w = \left[ \frac{\mu_b - \mu_r}{\left(\frac{\mu_b + \mu_r}{2}\right) - 1} \right]$$

## TUTORIAL SHEET: 9

### Interference

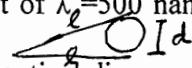
1. A soap-film of refractive index 1.33 is illuminated with light of different wave lengths at an angle of  $45^\circ$ . There is complete destructive interference for  $\lambda = 5890 \text{ \AA}$ . Find the thickness of the film. (1991)
2. An interference pattern is obtained by using two coherent sources of light, and the intensity variation is observed to be  $\pm 10\%$  of the average intensity. Determine the relative intensities of the interfering sources. (1993)
3. Show that the interference fringes in uncoated thin films are distinct when seen in reflection, but very indistinct in transmission. (1994)
4. In a biprism experiments the fringe-width with light of wavelength  $\lambda = 5900 \text{ \AA}$  is 0.43 mm. On introducing a mica sheet in the path of one of the interfering rays the central fringe shifts by 1.89mm. If refractive index of mica is 1.59, calculate the thickness of the sheet. (1995)
5. Show that the interference obtained in young's two-slit experiment are hyperbolic in shape. Under what conditions these are expected to appear straight? (1996)
6. Why does a Soap film appear coloured when it is viewed by reflected white light? A thin film is illuminated by sodium light of wavelength  $5900 \text{ \AA}$ . Its refractive index is 1.42. Calculate its minimum thickness so that it appears dark in reflected light. (1997)
7. What are the essential conditions for observing the interference of light? Two Coherent sources with intensity ratio 4:1 interfere. Find  $I_{\max}/I_{\min}$ .? (1999)
8. Why an extended source is necessary to see colours in a Soap-film? Non-reflecting surfaces are made by coating very thin films of a transparent material. Find the ~~minimum~~ minimum thickness of such thin coatings given that  $\lambda = 5.5 \times 10^{-5} \text{ cm}$  and  $\mu = 5/4$ . (1999)
9. Explain in detail how one can obtain fringes with the Michelson Interferometer using incandescent lamps. (2000)
10. Monochromatic light from a distance source of wavelength  $\lambda$  falls on a double slit. A glass plate of thickness  $t$  is inserted between one slit and the screen. Calculate the intensity at a central point as the function of thickness  $t$ . (2001)
11. In a experiment using a Michelson interferometer, explain with the help of suitable ray diagrams:
  - (i) Why do we need extended sources of light,
  - (ii) Why do we get circular fringes, and
  - (iii) Shifting of fringes inwards or outwards as we shift the movable mirror. (2002)
12. Two microscope slides of length 10cm each form a wedge. At one end they are in contact and at the other end they are separated by a thin wire of diameter  $d$ . ( see the diagram below). Interference fringes are obtained when illuminated vertically by a monochromatic light of  $\lambda = 500$  nanometers. The fringe spacing is found to be 1.25 mm. Estimate the diameter of the wire.  (2004)
13. Explain the working of Michelson interferometer using appropriate optical diagram. Also draw paths of the rays. (2006)
14. Obtain the relation to find radii of the rings and the wavelength of light in Newton's circular ring. Calculate the radius of curvature of the convex glass surface where diameter of 5<sup>th</sup> and 15<sup>th</sup> bright rings formed by sodium yellow light are measured to be 2.303 mm and 4.134 mm. Given  $\mu = 1.5$  and  $\lambda_{\text{yellow}} = 5282 \text{ \AA}$ . (2006)
15. Describe the working of a Fabry - Perot interferometer. Determine the intensity of the fringes of the transmitted light. Why the fringes obtained in the Fabry - Perot interferometer are comparatively sharper than those obtained from the Michelson interferometer? (2007)
16. Let the two waves with parallel electric fields be given by

$$E_1 = 2 \cos \left( \vec{k}_1 \cdot \vec{r} - \omega t + \frac{\pi}{3} \right) kV/m,$$

$$E_2 = 5 \cos \left( \vec{k}_2 \cdot \vec{\rho} - \omega t + \frac{\pi}{4} \right) kV/m.$$

Find the intensity of each beam  $I_1, I_2$  and also the interference term  $I_{12}$  at a point where their path difference is zero. Calculate the visibility

$$V = \left( \frac{I_{\max} - I_{\min}}{I_{\max} + I_{\min}} \right) \text{ for the interference pattern.}$$

$$[\epsilon_0 = 8.85 \times 10^{-12} C^2 / Nm^2, \mu_0 = 4\pi \times 10^{-7} N/A^2] \quad (2008)$$

17. Let

$$E_A = E_1 \sin \omega t \text{ and } E_B = E_2 \sin(\omega t + \phi)$$

By using analytical method, obtain an expression to explain interference. Also show that intensity varies along the screen in accordance with the law of cosine square in interference pattern

(2009)

18. Explain the phenomenon of interference in thin films. Why is the contrast better in brightness of fringes obtained from the interference of reflected light rays compared to the transmitted light rays?

(2009)

19. Describe Michelson interferometer for evaluation of coherence length of an optical beam. Calculate coherence length of a light beam of wavelength 600 nm with spectral width of 0.01 nm.

(2010)

20. Show that two light beams polarized in perpendicular directions will not interfere.

(2010)

21. An optical beam of spectral width 7.5 GHz at wavelength  $\lambda = 600$  nm is incident normally on Fabry-Perot etalon of thickness 100 mm. Taking refractive index unity find the number of axial modes which can be supported by the etalon.

(2010)

In general,  $I \propto \langle E^2 \rangle$  ← avg. val. time

$$= \langle \vec{E} \cdot \vec{E} \rangle$$

$$= \langle (\vec{E}_1 + \vec{E}_2) \cdot (\vec{E}_1 + \vec{E}_2) \rangle$$

## TUTORIAL SHEET: 10

### Diffraction

\* First image does not mean position wise. It means image corresponding to 1<sup>st</sup> focus

1. The diameter of the central zone of a zone-plate is 2.3 mm. If a point source of light ( $\lambda = 589.3$  nm) is placed at a distance of 6 metres from it, calculate the position of the first image. (1988)
2. In double-slit Fraunhofer diffraction; calculate the fringe spacing on a screen 50 cm away from the slits. If they are illuminated with blue light  $\lambda = 4800 \text{ \AA}$ , slits separation  $d = 0.10$  mm, and slit-width  $a = 0.020$  mm. What is the linear distance from the central maximum of the first minimum of the fringe-envelope? (1989)
3. A single slit of width 0.14 mm is illuminated normally by monochromatic light and diffraction bands are observed on a screen 2 m away. If the centre of the second dark band is 1.6 cm from the middle of the central bright band, deduce the wavelength of light. (1990)
4. Show schematically the intensity distribution for a 2-slit Fraunhofer diffraction-interference, if slit-widths are  $2\lambda$  each and centres of slits have separation  $6\lambda$ . Assume incident light falling normally, and limit the discussion to the central diffraction band range. (1990)
5. Distinguish between Fresnel and Fraunhofer classes of diffraction of light. Discuss the theory of plane grating and hence find an expression for the angular dispersion of a plane-grating.  $(d\theta/d\lambda)$  (1992)
6. What is Fraunhofer diffraction? Under what conditions may it be observed? Find an expression for the intensity distribution in double slit Fraunhofer diffraction, taking the result for diffraction at a single slit as given. (1993)
7. Obtain the intensity pattern due to Fraunhofer diffraction at two parallel slits. Each slit has a width 'a' and the separation between the slits is 'd'. How many interference fringes will appear in the central diffraction maximum, if  $d = 4a$ ? *Bright fringes...* (1995)
8. Give the concept of Fresnel's half period zones. Describe the salient features of Fresnel's diffraction pattern due to a straight edge, showing the intensity distribution. How are these features explained? (1997)
9. Differentiate between Fresnel and Fraunhofer diffractions. How can one explain the Fresnel diffraction pattern due to a straight edge? (1999)
10. Discuss the Fresnel diffraction pattern formed by a straight edge using the Cornu's spiral. (2002)
11. Obtain an expression for the intensity of light in the Fraunhofer diffraction pattern due to a circular aperture. What is Airy pattern? Explain with a neat diagram. (2003)
12. A narrow slit illuminated by monochromatic light of  $\lambda = 6400 \text{ \AA}$  is placed at a distance of 3 metres from a straight edge and the screen is 6 metres, Calculate the distance between the first and the fourth dark bands. (2004)
13. What is the essential difference between interference and diffraction of light? How can you achieve Fraunhofer diffraction in the laboratory? Using the concept of Fraunhofer diffraction at a single slit, find out the intensity distribution produced by two slits of equal width. (2005)
14. The radius of the first zone in a zone plate is 2 mm. What will be the position of the first image of a point source of light of wavelength  $\lambda = 500$  nm placed at a distance of 5 m from the zone plate? (2007)
15. Obtain the expression for the primary focal length of Fresnel zone plate. (2010)

## TUTORIAL SHEET :11

### (Resolving Power of Instruments)

1. State Rayleigh criterion for limit of resolution. Show that  $\frac{I_{\text{middle}}}{I_{\text{max}}} = \frac{8}{\pi^2}$  (1992)
2. A diffraction grating with  $3 \times 10^4$  lines is used in the second order in the range of wavelength  $6000 \text{ \AA}$ . Find the smallest ( $\Delta\lambda$ ) it can resolve. (1992)
3. Discuss the theory of diffraction grating and find conditions for the absent spectra. Distinguish between resolving power and dispersive power of a grating. (1994)
4. The angular separation between two distant stars is 1 arc - second. If the effective wavelength of light is  $5500 \text{ \AA}$ , what should be the diameter of the objective of a telescope so that the stars are just resolved? (1996)
5. A plane transmission grating has 6000 lines per cm. Determine the angular separation between the two lines of sodium of wavelengths  $5896 \text{ \AA}$  and  $5890 \text{ \AA}$  in the second order spectrum. If the width of the grating is 2.5 cm., will these lines be resolved? (1997)
6. Define dispersive and resolving powers of a plane transmission grating and obtain expressions for the two. Show that the first and second order spectra produced by such a grating will never overlap when the incident light contains wavelengths in the range of  $4000 \text{ \AA}$  to  $7000 \text{ \AA}$ . (1998)
7. Explain the terms resolving power and magnifying power of an optical instrument. On what parameter do these physical quantities depend in case of a telescope? For a given resolving power what is the optimum magnifying power in this case? (1998)
8. Sodium light is incident normally upon a plane transmission grating having 5000 lines/cm. Calculate the angular separation of the  $D_1$  and  $D_2$  lines in the first order spectrum. As their angular separation is very small, how can one magnify it 10 times?  
(Given  $\lambda D_1 = 5890 \text{ \AA}$ , and  $\lambda D_2 = 5896 \text{ \AA}$ ) (1999)
9. Give Rayleigh criterion for resolution. Why telescopes with larger objectives are better? The objective of the telescope at St. Palomer has a diameter of 5.08m. What is the least distance on Moon, which can be resolved by it? (Given: distance Moon from the earth = 3,84,000 km. &  $\lambda = 5890 \text{ \AA}$ ). (1999)
10. Derive the expression for resolving power of a diffraction grating with N lines. Calculate the minimum number of lines in the diffraction grating if it has to resolve the yellow lines of sodium (589 nm and 589.6 nm) in the first order. (2002)
11. Define resolving power and dispersive power of a grating. Two spectral lines of wavelengths 500 nm are seen clearly resolved in second order spectrum of a grating. If the grating has 250 lines per cm, what should be the minimum width of the grating? (2007)
12. Calculate the Fraunhofer diffraction pattern from a grating of N slits with width e, separated by equal opaque spaces d. Find the condition for principal maxima and the corresponding values of intensity. A parallel beam of Na light is incident normally on a plane grating with 4250 lines per cm. The second order spectral line is observed to be deviated through  $30^\circ$ . Calculate the wavelength of light. (2008)
13. (i) Distinguish between high dispersive power and high resolving power.  
(ii) Obtain an expression for the resolving power of a plane transmission grating.  
(iii) Deduce the missing orders for a double-slit Fraunhofer pattern, if the slit widths are 0.16 mm and 0.8 mm apart. (2009)

**TUTORIAL SHEET: 12****Polarization**

✓ 1. A beam of linearly polarized light is changed into circularly polarized light by passing it through a slice of crystal 0.003 cm. thick. Calculate the difference in refractive index of two rays in crystal assuming this to be minimum thickness that will produce the effect and that the wavelength of light is  $6 \times 10^{-7}$  m.

(1988, 1989)

✓ 2. Explain mathematically how left and right circularly polarized light is produced by combining two linearly polarized beams. Given a beam of light, how can one experimentally test whether it is unpolarized or circularly polarized?

(1990)

✓ 3. Deduce the possible thickness of a quarter wave plate of quartz which is to be used for Sodium light of wavelength  $5890 \text{ \AA}$ . ( $\mu_o = 1.658$ ,  $\mu_e = 1.486$ )

(1991)

✓ 4. Give an outline of Fresnel's explanation of optical rotation. How does optical rotation due to material vary with  $\lambda$ ?

For an optically active material the difference between the refractive indices for right-handed and left-handed vibrations ( $\mu_R - \mu_L$ ) for  $\lambda = 4500 \text{ \AA}$  is  $12 \times 10^{-5}$ . Estimate the optical rotation caused by 1mm thick plate in light of  $\lambda = 4500 \text{ \AA}$ . Assume ( $\mu_R - \mu_L$ ) to be independent of  $\lambda$ .

(1992)

✓ 5. Give an account of the origin of optical activity in quartz crystal. A wafer of crystalline quartz of thickness  $2.945 \times 10^{-5}$  m is used to change a beam of linearly polarized light ( $\lambda = 589 \text{ nm}$ ) into circularly polarized light. Find the difference in refractive index for the two waves in the crystal, assuming this to be minimum thickness that will produce the effect?

(1993)

✓ Describe how Fresnel has accounted for the rotation of the plane of polarisation of light. Explain the action of a half-shade device.

(1994)

✓ 7. A left circularly polarized beam of light ( $\lambda = 6000 \text{ \AA}$ ) is incident on a quartz crystal (optic axis parallel to the surface). Find the state of polarisation of the emergent beam. (Thickness of quartz crystal =  $2.3 \times 10^{-5}$  m,  $\mu_e = 1.5538$ ,  $\mu_o = 1.5444$ ).

(1995)

✓ 8. What is a quarter wave plate? Explain its use in the production and detection of circularly polarized light. For calcite  $\lambda = 5472 \text{ \AA}$ ,  $\mu_o = 1.659$  and  $\mu_e = 1.488$ . If the minimum thickness of a plate that can be cut from calcite is  $30 \text{ \mu m}$ , what should be the minimum thickness for preparing a quarter wave plate?

(1996)

✓ 9. What is a quarter plate? A phase retardation plate of quartz has a thickness 0.1436 mm. Calculate the wavelength in the visible region for which this plate will act as a quarter wave plate. The refractive indices of quartz for ordinary and extra ordinary rays are 1.5443 and 1.5533 respectively.

(1999)

✓ 10. Four perfect polarizing plates are stacked so that the axis of each is turned  $30^\circ$  clockwise with respect to the preceding plate; the last plate is crossed with the first. How much of the intensity of an incident unpolarized light is transmitted by the stack?

(2000)



✓ 11. Why does one get polarized light from Nicol's prism? How should one adjust the polarizer and analyser, so that an intensity of the incident light is reduced by a factor of 0.25.

✓ 12. How do you know that the light is a transverse wave? What is a quarter wave plate? How is it constructed? (2002)

✓ 13. A quartz quarter wave plate is to be used with the sodium light ( $\lambda=5869 \text{ \AA}$ ). What should be its thickness. (2004)

✓ 14. Why does one see two image points for a single object point while viewed through a calcite crystal? What is this property of the crystal known as? What is an optic axis of a crystal? Explain the meaning of positive and negative crystals with one example for each kind. (2005)

✓ 15. What is optical activity? Give reasons for the conclusion that optical rotation in liquids has a molecular origin. What do you mean by ordinary and extraordinary rays? What are positive and negative crystals? Give an example of each. Compute the minimum thickness of a quarter-wave plate made from quartz for incident wavelength of 589.3 nanometer. Given  $\mu_o = 1.544$  and  $\mu_e = 1.553$ . (2006)

✓ 16. How would you produce plane polarized light by reflection? What is Brewster's law? Calculate the angular position of the sun above the horizon so that light reflected from a calm lake is completely polarized. The refractive index of water is 1.33. Circularly polarized and unpolarized light are passed in turn through a Nicol prism. The Nicol is rotated about the direction of light as axis. What would you observe in each case? How would you distinguish between them? (2006)

✓ 17. Consider superposition of two plane polarized electromagnetic waves:

$$E_y = \hat{y} a \cos(kx - \omega t) \text{ and}$$

$$E_z = \hat{z} b \cos(kx - \omega t + \phi)$$

Discuss the conditions for the resultant wave to be left circularly and right circularly polarized adopting the convention as seen by an observer traveling with the wave. (2007)

✓ 18. (i) Show that the plane of polarization is rotated through

$$\theta = \frac{\delta}{2} = \frac{\pi d}{\lambda} (\mu_L - \mu_R)$$

(ii) A plane-polarised light is incident perpendicularly on a quartz plate with faces parallel to optic axis. Find the thickness which introduces phase difference of  $60^\circ$  between e- and o-rays. (2009)

*This is always the case  
st. light emitted  
out of crystal is combination  
of o + e rays.*

9

**TUTORIAL SHEET: 13****LASERS**

1. A ruby laser produces a beam of light of wavelength  $6943 \text{ \AA}$  with a circular cross-section of 1cm in diameter. Calculate the diameter of this beam at a distance of 1000 kilometers.

(1992)

2. Explain the general principle of laser action. What do you mean by population inversion? Discuss the involved in the ruby laser. A pulsed laser is rated at 10 m W. It generates 3 ns wide pulses at frequency 500 HZ. Compute the instantaneous power in the pulse.

(1993)

3. The light ( $\lambda = 6000 \text{ \AA}$ ) from a laser of sectional diameter 1.0cm and power 0.20 watt is focused by a lens of focal length 10cm. Determine the area of the image and intensity in it in  $\text{watt/cm}^2$ .

(1994)

4. Discuss the working principle of He - Ne laser indicating the transitions involved in the process. Determine the power output of a laser in which a 3.0 J pulse is delivered in 1.0 n second.

(1995)

5. Describe the working principle of a three level solid state laser giving the transitions involved in the laser action.

(1996)

6. Obtain an expression for the ratio of the probabilities of stimulated and spontaneous emissions. What do you infer from this relation? How is population inversion interpreted thermodynamically?

(1996)

7. In a hydrogen atom for the  $2p \rightarrow 1s$  transition the probability per unit is  $6 \times 10^8 \text{ s}^{-1}$ . Calculate the angular frequency of the emitted photons and the order of Einstein's coefficient  $B_{21}$ .

(1997)

8. A 3 MW laser beam which has a diameter of 1cm is focused by a lens of focal length 5 cm. The wavelength of laser is  $10,000 \text{ \AA}$ . Calculate the intensity at the focal plane of the lens.

(1997)

9. What is population inversion? Mention the methods of achieving population inversion. Explain the concept of negative temperature.

(1997)

10. A short - focus lens is used to focus a laser beam of wavelength  $6328 \text{ \AA}$ . If the beam width is comparable to the focal length of the lens, calculate the area of cross-section of the region of focus.

(1999)

11. Explain why a two - level system is not adequate for laser operation. Draw the essential parts of a ruby laser and explain the working principle.

(1999)

12. Explain the phenomenon of self focussing of laser beams.

(2003)

CA  
nonlinear  
change in  
self focusing



10  
one of the  
reason for  
straight line  
movement

13. Explain how Einstein's A and B coefficients are related to the phenomena of spontaneous and stimulated emission of radiation, respectively. Derive the relation between A and B. Establish that at very high frequency around X-ray wavelength regime, lasers cannot be made as easily as at low frequencies, e.g., far infra-red regime.

14. Consider an ensemble of two - level atoms in thermal equilibrium. Show that the ratio of Einstein A and B coefficients is given by

$$\frac{A}{B} = \frac{8\pi h\nu^3}{c^3}$$

Why is it not possible to achieve inversion of population in a two- level medium?

(2008)

15. What are the characteristics of stimulated emission? Show that in the optical region stimulated emission is negligible compared to spontaneous emission.

(2009)

16. (i) At what temperature are the rates of spontaneous and stimulated emission equal?

(Assume  $\lambda = 500$  nm)

(2009)

(ii) What are the important properties of a hologram?

(iii) Optical power of 1 mW is launched into an optical fiber of length 100 m. If the power emerging from the other end is 0.8 mW, calculate the fiber attenuation.

(2009)

17. A laser beam of 1 micrometer wavelength with 3 megawatts power of beam diameter 10 mm is focused by a lens of focal length 50 mm. Evaluate the electric field associated with the light beam at the focal point.

(Dielectric permittivity of free space,

$$\epsilon_0 = 8.8542 \times 10^{-12} \text{ C}^2 / \text{N} - \text{m}^2)$$

(2010)

$$u_{B_{12}} = u_{B_{21}}$$

$\Rightarrow$  Probability of transition is same.

(11)

**TUTORIAL SHEET: 14****(Special Topics)**

✓ 1. What is a hologram? Explain how the image of the object is formed when one looks through it. ✓

(1990)

~~2.~~ Define coherent length. A helium - neon laser emits radiation at wavelength  $\lambda = 623.8$  nm with  $\Delta\lambda = 2$  pm. Calculate the coherent wave

(1993)

✓ 3. What is meant by temporal and spatial coherence? Show that the coherence length  $L = \lambda Q$  where  $\lambda$  is the mean wave length and  $Q$  represents the purity of a

(1996)

~~4.~~ What is spatial coherence? Considering young's two slit experiment, prove that the distance between the slits must be sufficiently less than  $\left(\frac{\lambda}{\theta}\right)$  for obtaining fringes of good contrast  $\lambda$  is the wavelength of light used and  $\theta$  is the angle subtended by the source <sup>upon</sup> slits.

(1997)

✓ 5. Explain the phenomenon of pulse dispersion in step index fibre. ✓

(2003)

X 6. What is holography? Describe the experimental set up for Gabor's on-line holographic recording. What are the limitations of Gabor's experiment? How were these overcome by Leigh and Upatheiks?

(2003)

✓ 7. Drawing a neat diagram, discuss how light travels through on optical fiber. Show that the numerical aperture of a commercially available optical fiber is around 0.25. Explain its physical significance. ✓

✓ 8. Why does one get three-dimensional image in holography? Explain with appropriate figures how can one construct and read a hologram. ✓

(2005)

(12)

# Lens system via matrix method

(1)

$f, u$  and  $v$  are measured from the unit planes always. For thin lens, unit planes are at centre of lens only.

~~$f=0$  if  $y=0$  only for thin lens.  
 $\Rightarrow$  we get lens maker formula~~

## Thin lens

$$\begin{bmatrix} 1 & 0 \\ v & 1 \end{bmatrix} \begin{bmatrix} 1 & -P \\ 0 & 1 \end{bmatrix} \begin{bmatrix} 1 & 0 \\ -u & 1 \end{bmatrix} \\ = \begin{bmatrix} 1 & 0 \\ v & 1 \end{bmatrix} \begin{bmatrix} 1+Pu & -P \\ -u & 1 \end{bmatrix} = \begin{bmatrix} 1+Pu & -P \\ v+Pu+u & -Pv+1 \end{bmatrix}$$

From  $y_2=0$  if  $y_1=0$ , we get  $v-u+Puv=0$   
 $\Rightarrow \underline{\underline{\frac{1}{v} - \frac{1}{u} = \frac{1}{f}}}$

From Magnification = 1  $\Rightarrow -Pv+1=1 \Rightarrow v=0$   
 determinant = 1  $\Rightarrow 1+Pu=1 \Rightarrow u=0$

$\Rightarrow$  Unit planes coincide :  $v=0, u=0$  with the lens

Hence net matrix :  $\begin{bmatrix} 1 & -\frac{1}{f} \\ 0 & 1 \end{bmatrix}$

To find focal length :

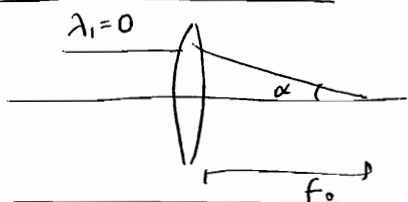

$$\begin{bmatrix} \lambda_2 \\ y_2 \end{bmatrix} = \begin{bmatrix} 1 & -\frac{1}{f} \\ 0 & 1 \end{bmatrix} \begin{bmatrix} 0 \\ y_1 \end{bmatrix}$$

$$\Rightarrow y_2 = y_1, \lambda_2 = -\frac{1}{f} y_1 \\ = -\frac{1}{f} y_2 \\ \Rightarrow -d = -\frac{1}{f_0} y_2 \Rightarrow \frac{1}{f_0} = \frac{1}{f}$$

★ 2 Thin lenses separated by a distance  $t$

Note that if we make equivalent thin lens, where to keep it?

Actually, we reduce the system to 2 unit planes:

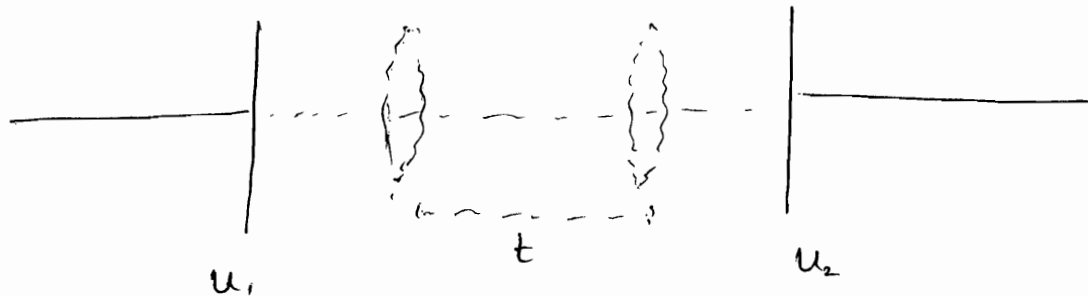

Now we measure  $u$  and  $v$  from  $u_1$  and  $u_2$  respectively and apply the equivalent matrix.

Now aim is to find  $\rightarrow$  equivalent matrix  
 $\rightarrow$  positions of  $u_1$  and  $u_2$

To find unit planes:

$$\begin{bmatrix} 1 & 0 \\ v & 1 \end{bmatrix} \begin{bmatrix} 1 & -p_2 \\ 0 & 1 \end{bmatrix} \begin{bmatrix} 1 & 0 \\ t & 1 \end{bmatrix} \begin{bmatrix} 1 & -p_1 \\ 0 & 1 \end{bmatrix} \begin{bmatrix} 1 & a \\ -u & 1 \end{bmatrix}$$

$$= \begin{bmatrix} 1 & 0 \\ v & 1 \end{bmatrix} \begin{bmatrix} 1 - tp_1 & -P_{eff} \\ t & 1 - tp_2 \end{bmatrix} \begin{bmatrix} 1 & 0 \\ -u & 1 \end{bmatrix}$$

$$= \begin{bmatrix} 1 - tp_1 + P_{eff} u & -P_{eff} \\ (1 - tp_1)v + P_{eff} uv + t - (1 - tp_2)u & -P_{eff} v + 1 - tp_2 \end{bmatrix}$$

Now for unit plane:  $-P_{eff} v + 1 - tp_2 = 1$

$$\Rightarrow v = -\frac{(tp_2)}{P_{eff}}$$

From determinant = 1

$$1 - tP_1 + P_{eff} u = 1$$

$$u = \frac{tP_1}{P_{eff}}$$

Now from definition of focal length (measured from unit planes)

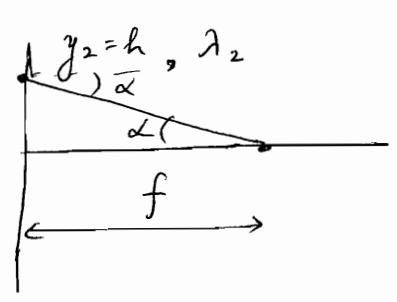
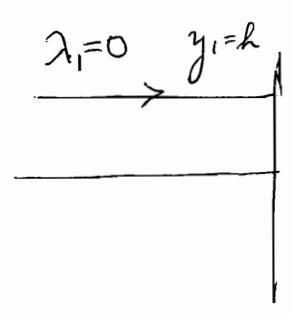

$$\lambda_2 = -\alpha_2$$

$$\begin{bmatrix} \lambda_2 \\ y_2 \end{bmatrix} = \begin{bmatrix} 1 \\ -(1-tP_1) \frac{tP_2}{P_{eff}} + P_{eff} \frac{tP_1 P_2}{P_{eff}} \\ + t - (1-tP_2) \frac{tP_1}{P_{eff}} \end{bmatrix}$$

$$\begin{bmatrix} -P_{eff} \\ 1 \end{bmatrix} \begin{bmatrix} \lambda_1 \\ y_1 \end{bmatrix} = \begin{bmatrix} 1 & -P_{eff} \\ 0 & 1 \end{bmatrix} \begin{bmatrix} 0 \\ y_1 \end{bmatrix}$$

$$\lambda_2 = -P_{eff} \cdot y_1 = -P_{eff} h$$

$$\lambda_2 = -\alpha_2 = -\frac{h}{f} = -P_{eff} h \rightarrow$$

$$\frac{1}{f} = -P_{eff}$$

$$\frac{1}{f} = \frac{1}{f_1} + \frac{1}{f_2} - \frac{t}{f_1 f_2}$$

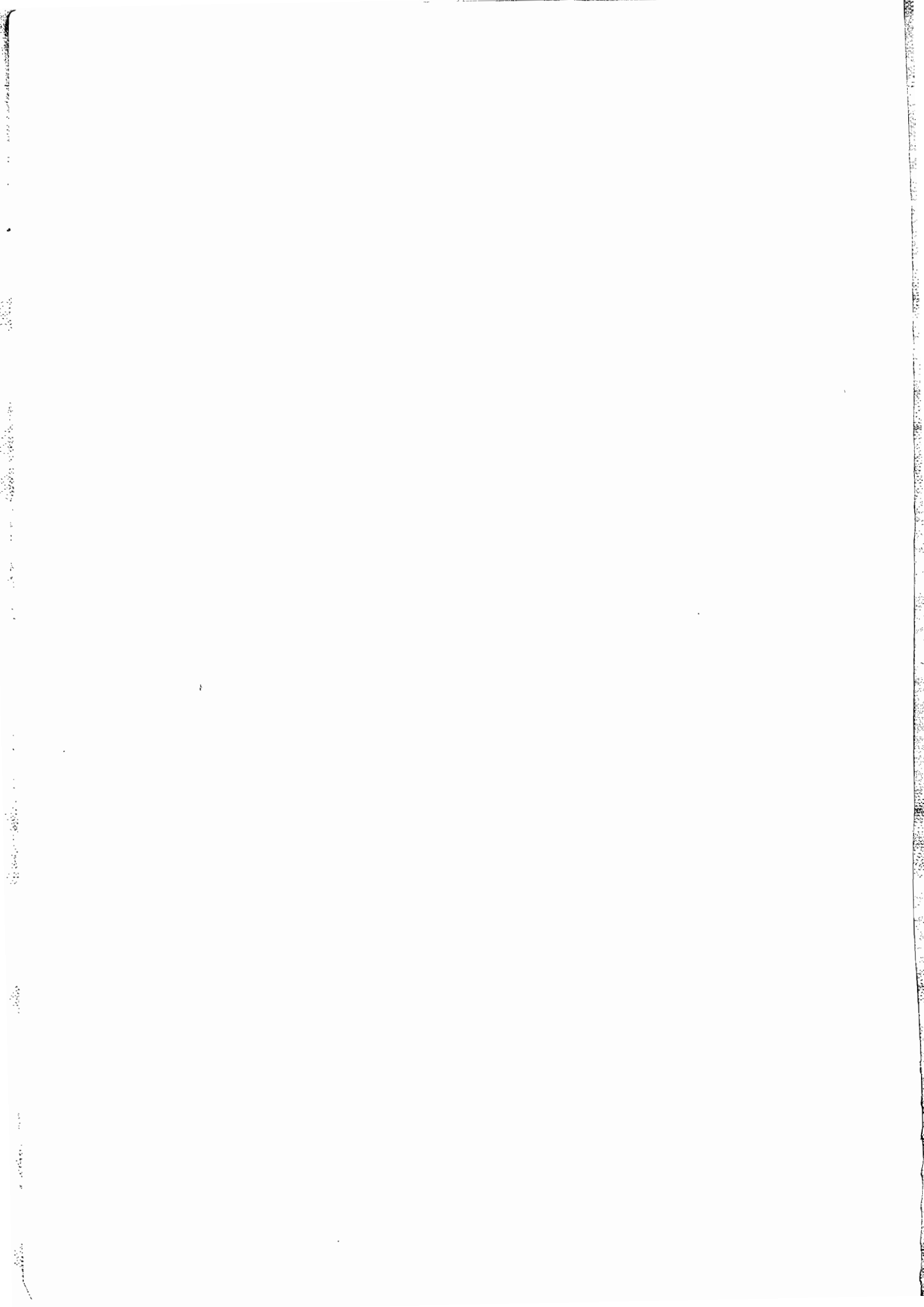



Also  $y_2 = M = [1 - vPeff]$

For ~~unit~~ <sup>unit</sup> points on ~~unit~~ <sup>unit</sup> planes,  $M = 1$  ~~2/2~~

$S = \begin{bmatrix} b & -a \\ -d & c \end{bmatrix} = \begin{bmatrix} 1 & -1/f \\ 0 & 1 \end{bmatrix}$  Thin Convex lens



Linear Magnification = 1 : Principal Points  
 Angular Magnification = 1 : Nodal Points

} if both, then we have nodal planes.

$c - aD_2 = \text{linear Magnification} = 1$

$\Rightarrow D_2 = \frac{c-1}{+a}$

$b - aD_1 = \frac{1}{M} = 1$

$\Rightarrow D_1 = \frac{1-b}{-a}$

} Principal Points  
 distance of unit planes from refracting surfaces.

@ Nodal Points :  $\frac{d_2}{d_1} = 1$

⊗ If both sides of optical system are in same medium, then principal points coincide with nodal points.

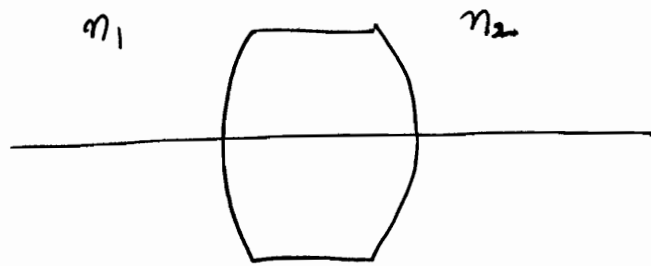

$$n_2 y_2 d_2 = n_1 y_1 d_1 \quad : \text{ Helmholtz Condition}$$

$$n_1 y_1 \tan \alpha_1 = n_2 y_2 \tan \alpha_2 \quad : \text{ Gaussian Condition}$$

$$n_1 y_1 \sin \alpha_1 = n_2 y_2 \sin \alpha_2 \quad : \text{ Abbe's sine Condition}$$

$$n_2 = n_1 \Rightarrow y_1 \sin \alpha_1 = y_2 \sin \alpha_2$$

$$\left( \frac{y_2}{y_1} \right) = \left( \frac{d_1}{d_2} \right)$$

If linear magnification is 1  
 $\Rightarrow$  angular magnification is also 1.

For most of the optical systems, principal points coincide with nodal points & hence there are two unit points.

System of two thin lenses

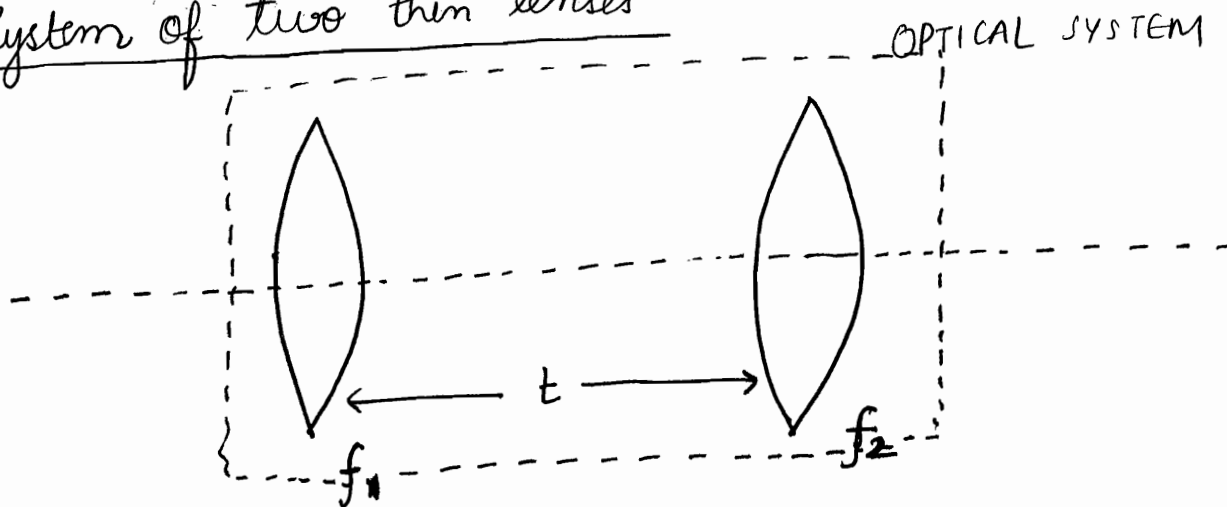

$$S = \begin{bmatrix} 1 & -P_2 \\ 0 & 1 \end{bmatrix} \begin{bmatrix} 1 & 0 \\ t & 1 \end{bmatrix} \begin{bmatrix} 1 & -P_1 \\ 0 & 1 \end{bmatrix}$$

$$P_2 = \frac{1}{f_2}$$

$$P_1 = \frac{1}{f_1}$$

$$S = \begin{bmatrix} 1 - tP_2 & (1 + tP_2)(-P_1) & -P_2 \\ t & -tP_1 + 1 & \text{(system matrix)} \\ & & -P_{eff} \end{bmatrix} = \begin{bmatrix} 1 - tP_2 & -P_{eff} \\ t & 1 - tP_1 \end{bmatrix}$$

We know that element  $a$  in the matrix represents reciprocal of focal length i.e.

$$P_{eff} = P_1 + P_2 - tP_1P_2$$

$$\frac{1}{f} = \frac{1}{f_1} + \frac{1}{f_2} - \frac{t}{f_1 f_2}$$

$$\begin{bmatrix} \lambda_2 \\ y_2 \end{bmatrix} = \begin{bmatrix} 1 & 0 \\ v & 1 \end{bmatrix} \begin{bmatrix} b & -a \\ -d & c \end{bmatrix} \begin{bmatrix} 1 & 0 \\ u & 1 \end{bmatrix} \begin{bmatrix} \lambda_1 \\ y_1 \end{bmatrix}$$



### ★ Unit Planes

Unit planes are two planes, one each in the object and the image space, between which magnification  $M$  is unity i.e. any paraxial ray emanating from the unit plane in object space will re-emerge at the same height from unit plane in the image space.

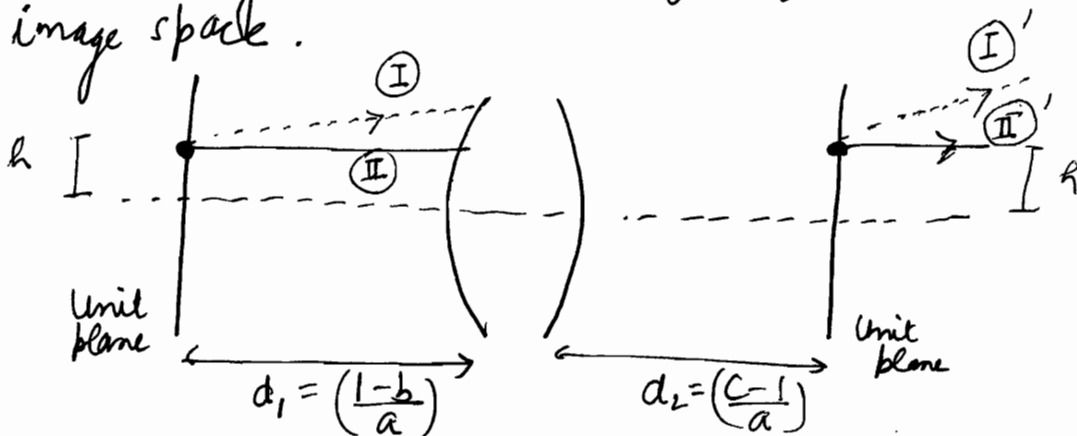

# Lens Maker's Formula from Fermat's Principle

We consider successive refractions at 2 surfaces

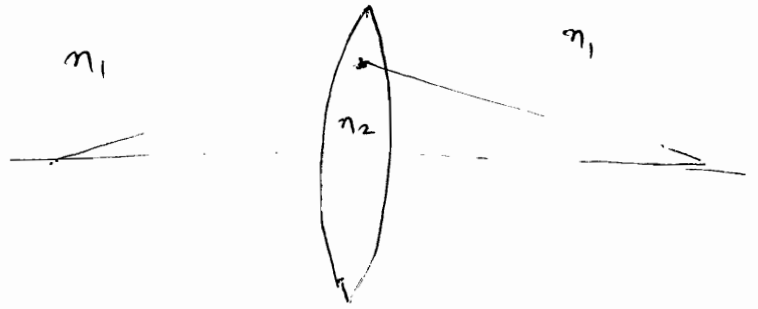

For 1<sup>st</sup> surface

$$\frac{n_2}{v_1'} - \frac{n_1}{u_1} = \frac{n_2 - n_1}{R_1} \quad - (1)$$

For 2<sup>nd</sup> surface

$$\frac{n_1}{v_1} - \frac{n_2}{v_1'} = \frac{n_1 - n_2}{R_2} \quad - (2)$$

$\Rightarrow$  From (1) and (2)

$$\frac{n_1}{v_1} - \frac{n_1}{u_1} = (n_2 - n_1) \left[ \frac{1}{R_1} - \frac{1}{R_2} \right]$$

$$\Rightarrow \frac{1}{v_1} - \frac{1}{u_1} = \left[ \frac{n_2}{n_1} - 1 \right] \left[ \frac{1}{R_1} - \frac{1}{R_2} \right]$$

~~Put~~ Put  $\frac{n_2}{n_1} = n$ , we have

$$\Rightarrow \boxed{\frac{1}{v_1} - \frac{1}{u_1} = (n-1) \left[ \frac{1}{R_1} - \frac{1}{R_2} \right] = \left( \frac{1}{f} \right)}$$

## Nodal Planes

Nodal points are two points on the axis which have relative angular magnification of unity

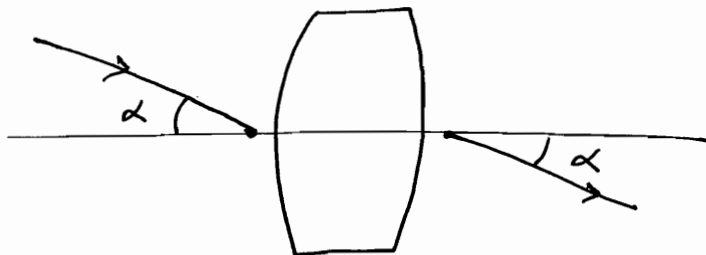

Note that for nodal planes, we consider  $y=0$ .

The ray striking the first point at angle  $\alpha$  emerges from second point at the same angle  $\alpha$ . Planes which pass through this point and are normal to the axis are called Nodal Planes.

If indices of refraction on both sides are same, then  $n_1 = n_2$  i.e. nodal planes and unit planes are same.

Note that unit planes can have object at any point on the plane, while in nodal plane we consider only the point on the axis. The points on unit planes are called Principal Points.

If  $n_1 \neq n_2$ , then the relationship between the two is governed by 3 conditions: Helmholtz/Abbe/Gaussian

★ For Convex lens

$$f = (n-1) \left[ \frac{1}{|R_1|} + \frac{1}{|R_2|} \right] > 0$$

In old people, long sightedness i.e. hypermetropia  
i.e. they can see at a distance but cannot focus  
on near objects

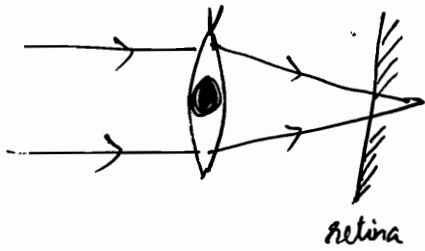

long sightedness

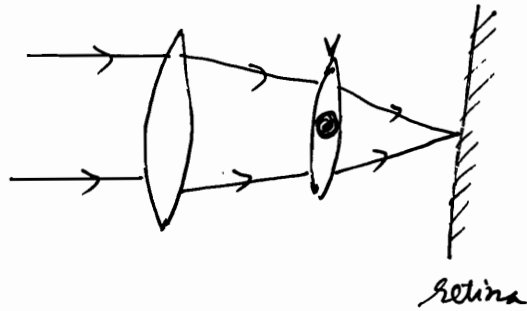

retina

⊕ve number of spectacles

★ For Concave lens

$$f = (n-1) \left[ -\frac{1}{|R_1|} - \frac{1}{|R_2|} \right] < 0$$

In children, short sightedness (lack of experience) i.e.  
myopia i.e. cannot focus on distant object

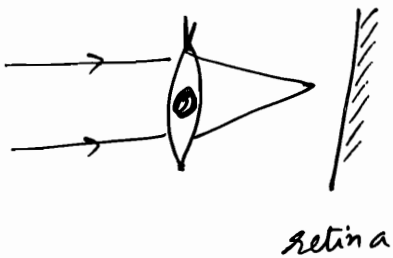

retina

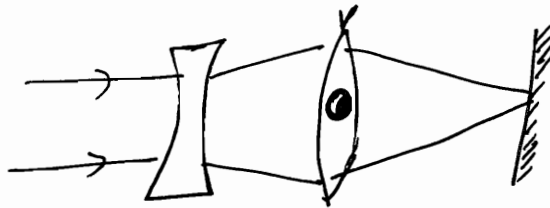

⊖ve number of spectacles

# OPTICS (7)

12/12/2011

## Interference

- Frequency should be same for interference, otherwise beats would also take place.
- $\vec{k}$  is along the direction of wave propagation.

- Interference
- Young's double slit
- Coloured Films
- Reflective & Anti-Reflective
- Wedge
- Newton's Rings
- Michelson
- Fabry Perot

◦ Coherence

In EM wave  $(\vec{E} \vec{B} \vec{k})$  form 3-d perpendicular triad.

$$\vec{E} \cdot \vec{B} = 0, \quad \vec{B} \cdot \vec{k} = 0, \quad \vec{E} \cdot \vec{k} = 0$$

$$|\vec{B}| = \left( \frac{|\vec{E}|}{c} \right)$$

$\Rightarrow B$  is negligibly small.

$\Rightarrow$  Majority of the phenomenon is due to  $\vec{E}$  !!

$$\Rightarrow y = a \sin(\omega t - kx)$$

↑

$y$  is majority  $\vec{E}$ .

[Energy per unit area per unit time]

Intensity of EM wave, called **POYNTING VECTOR**, is ~~called~~ defined as  $\frac{\vec{E} \times \vec{B}}{\mu} = \frac{1}{2} c \epsilon_0 E_0^2$

Intensity is maximized in interference, i.e.  $[E_0^2]$  maximum is looked for.

## Interference

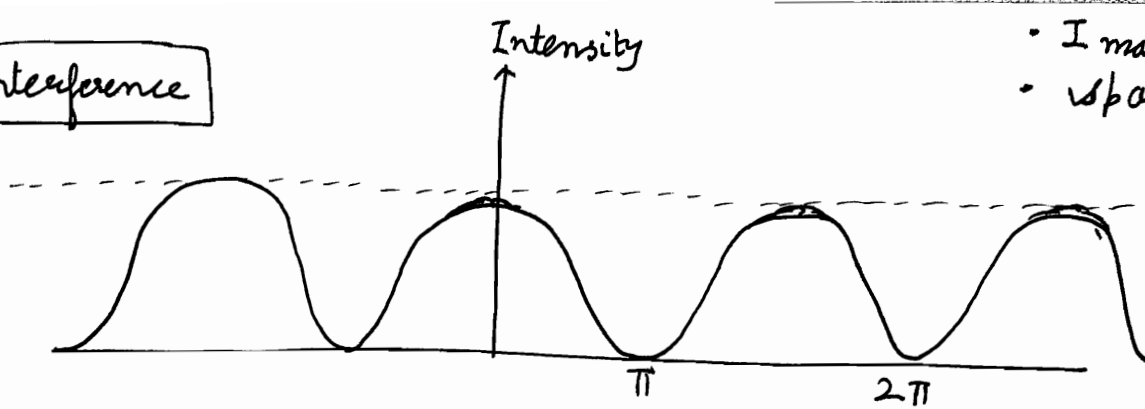

- I maxima Const.
- spacing b/w maxima Const

## Intensity Patterns

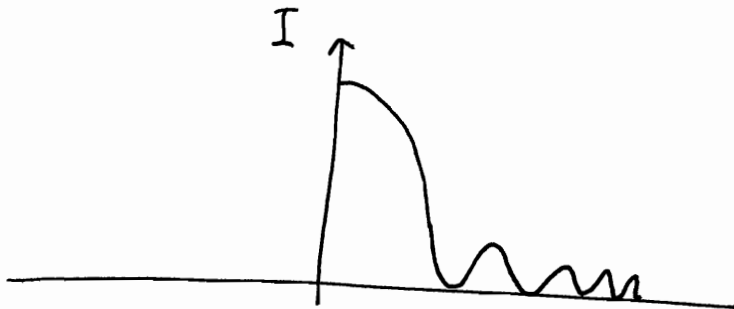

## Diffraction

- $I_{max} \downarrow$
- spacing b/w maxima  $\downarrow$

let us consider 2 waves,

$$y_1 = a_1 \sin(\omega t - kx)$$

$$y_2 = a_2 \sin(\omega t - kx + \phi)$$

3 conditions for observing interference pattern

① Both  $\omega$  are same.

② Interference waves are considered along same direction of polarization...

If we:  $y = f_2(x, t)$ ,  $z = f_1(x, t)$ , then conic section patterns will form, they are not interference desired.



Upon Superposition,

$$y = y_1 + y_2$$

$$= a_1 \sin(\omega t - kx) + a_2 \sin(\omega t - kx) \cos \phi \\ + a_2 \cos(\omega t - kx) \sin \phi$$

$$= [a_1 + a_2 \cos \phi] (\sin(\omega t - kx)) \\ + a_2 \sin \phi \cos(\omega t - kx)$$

$$\text{let } a_1 + a_2 \cos \phi = A \cos \delta$$

$$a_2 \sin \phi = A \sin \delta$$

$$y_{\text{net}} = A \sin(\omega t - kx + \delta)$$

$$A = \sqrt{[a_1 + a_2 \cos \phi]^2 + [a_2 \sin \phi]^2}$$

$$A = \sqrt{a_1^2 + a_2^2 + 2a_1 a_2 \cos \phi} \leftarrow \text{very significant}$$

$$\tan \delta = \left[ \frac{a_2 \sin \phi}{a_1 + a_2 \cos \phi} \right] \leftarrow \text{no significance}$$

$$I = \frac{1}{2} c \epsilon_0 A^2$$

$$\Rightarrow I_{\text{result}} = I_1 + I_2 + 2\sqrt{I_1 I_2} \cos \phi$$

$$\phi = \frac{2\pi}{\lambda} \Delta$$

↑  
Path difference

⊛ Note that in constructive & destructive interference, there is no violation of energy conservation; the energy is merely redistributed!!

if  $\Delta$  is fluctuating  $\Rightarrow \phi$  will fluctuate

$\Rightarrow I_{\text{result}}$  is fluctuating

$$\Rightarrow I_{\text{result avg}} = I_{1 \text{ avg}} + I_{2 \text{ avg}} + 2\sqrt{I_{1 \text{ avg}} I_{2 \text{ avg}}} (\cos \phi)_{\text{avg}}$$

$$I_{\text{result avg}} = I_{1 \text{ avg}} + I_{2 \text{ avg}} \quad \Rightarrow \text{No interference. } I_{\text{avg.}} \text{ same everywhere.}$$

③  $\Rightarrow \phi$  should not be function of time  
ie. sources should be coherent i.e. having constant phase difference.

$$\left[ \frac{d\phi}{dt} \right] = 0$$

④ Path difference  $<$  coherence length

We have temporal & spatial coherence.

For coherent sources,

$$I_{\text{Maximum}} = I_1 + I_2 + 2\sqrt{I_1 I_2}$$

$$A^2 = (A_1 + A_2)^2$$

$$I_{\text{Minimum}} = I_1 + I_2 - 2\sqrt{I_1 I_2}$$

$$A^2 = (A_1 - A_2)^2$$

Maxima @  $\cos \phi = 1 \Rightarrow \pm \phi = 2n\pi$   $n=0, 1, 2, \dots$   
 $= 0, 2\pi, 4\pi, 6\pi, \dots$

Minima @  $\cos \phi = -1 \Rightarrow \pm \phi = (2n+1)\pi$   $n=1, 2, 3, \dots$   
 Make it a habit of using  $(2m-1)\pi = \pi, 3\pi, 5\pi, \dots$

$$\Delta_{\text{maxima Intensity}} = \pm \frac{\lambda}{2\pi} \cdot 2n\pi$$

$$n = 0, 1, 2, \dots$$

$$= \pm n\lambda$$

$$= \pm 0, \lambda, 2\lambda, \dots$$

$$\Delta_{\text{minima intensity}} = \pm \frac{\lambda}{2\pi} \cdot (2n+1)\pi$$

$$n = 1, 2, 3, \dots$$

$$= \pm \left(n + \frac{1}{2}\right) \lambda$$

$$= \pm \frac{\lambda}{2}, \frac{3\lambda}{2}, \frac{5\lambda}{2}, \dots$$

Fringe width = distance b/w 2 maxima on screen  
 = distance b/w 2 minima on screen

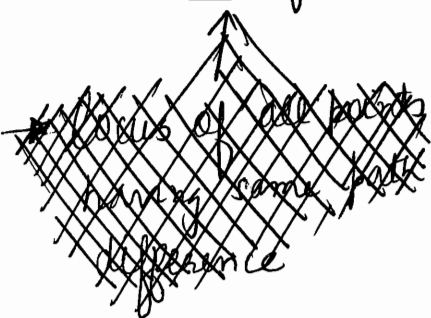

all equal  
to fringe  
width.

→ If  $I_1 = I_2 \Rightarrow$  contrast b/w maxima and minima would be easy to observe. Its not a precondition for interference, its just an enabling factor for easy observation.

$$\Rightarrow I = 2A^2 [1 + \cos \phi]$$

$$= 2A^2 \cdot 2 \cos^2 \frac{\phi}{2}$$

$$= 4A^2 \cos^2 \left(\frac{\phi}{2}\right)$$

Time Period =  $2\pi$

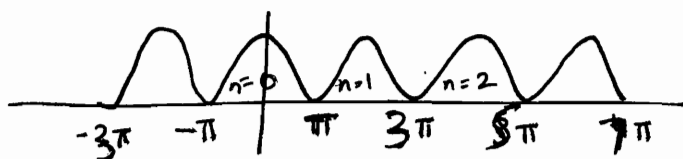

light from 2 sources cannot be coherent, hence in order to produce coherence, 2 different ways

(i) division of wave front class

eg. Young's Double Slit Experiment.

Fresnel's Biprism (Refraction <sup>via</sup>)

S Lloyd's Mirror (Reflection <sup>via</sup>)

(ii) division of amplitude class

eg. colours produced by thin films

Newton's rings

Michelson's interferometer

Fabry - Perot interferometer

Wedge Shaped Films

### Division of Amplitude

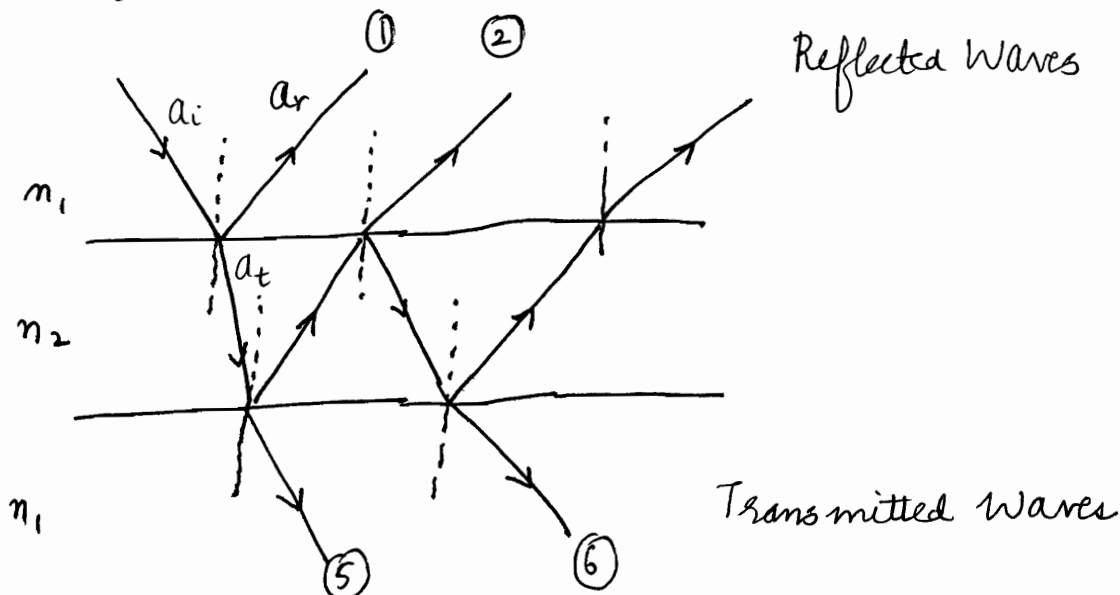

Note that in reflected wave : 1<sup>st</sup> : ar    2<sup>nd</sup> : at<sup>2</sup>R    3<sup>rd</sup> : at<sup>2</sup>R<sup>2</sup> ..

→ Hence completely dark fringe ar

For normal incidence,

$$a_r = \frac{(n_1 - n_2)}{(n_1 + n_2)} a_i$$

$$a_t = \left( \frac{2n_1}{n_1 + n_2} \right) a_i$$

Fresnel Formulae  
for  
normal incidence  
or  $i=0$

$$a_1 \approx a_2$$

$$a_5 \neq a_6$$

⇒ reflected waves show better interference.

Division of Wavefront

Young's Double Slit Experiment

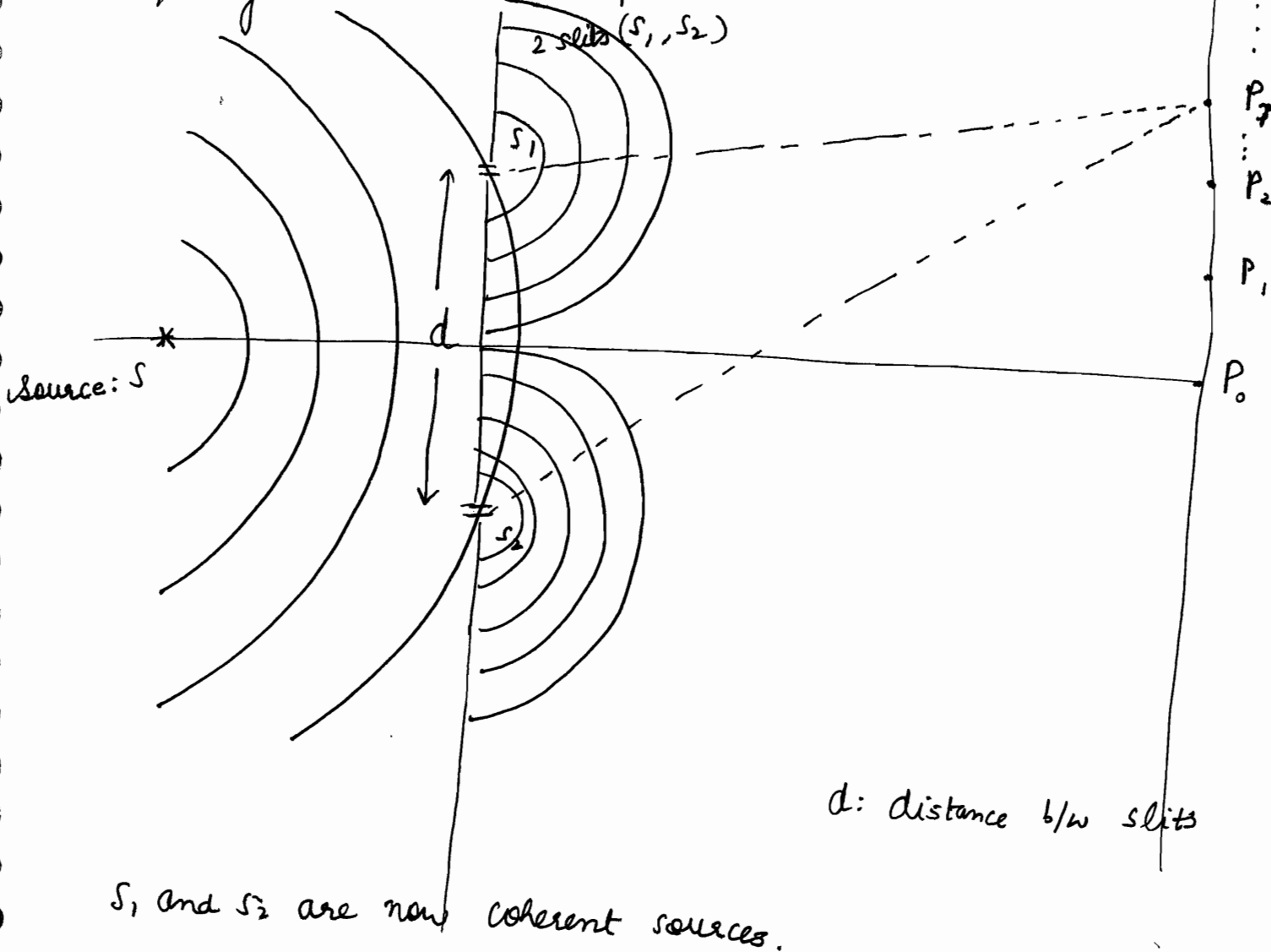

$d$ : distance b/w slits

$S_1$  and  $S_2$  are now coherent sources.

$$S_2 P_n - S_1 P_n = \Delta$$

depending on  $\Delta$ , we have maxima & minima.

$$\begin{array}{ccc} \uparrow & & \uparrow \\ \pm n\lambda & & \pm \left(n - \frac{1}{2}\right)\lambda \end{array}$$

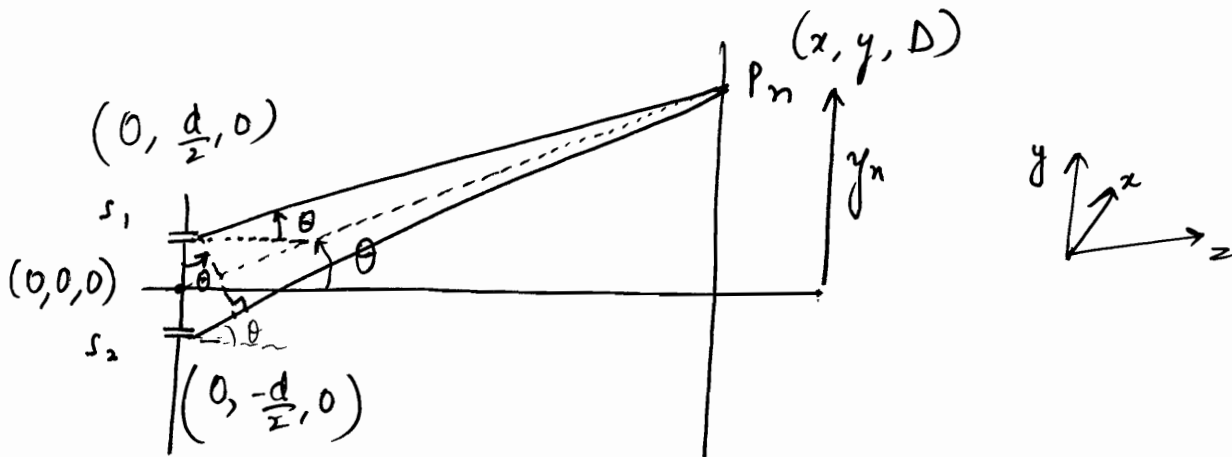

$$D \gg d$$

$d$  is in  $\text{\AA}$  comparable to  $\lambda$   
 $D$  is in cm or m.....

$$\Delta = d \sin \theta$$

$$\Rightarrow \text{Maxima at } d \sin \theta = n\lambda$$

$$\text{Minima at } d \sin \theta = \left(n - \frac{1}{2}\right)\lambda$$

$y_n$  is the distance of  $n^{\text{th}}$  maxima from central maxima

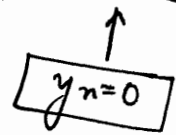

Note that  $\theta \approx \frac{y_n - d/2}{D} \approx \frac{y_n}{D} \approx \theta$

(blue) (red)

$$\Rightarrow \Delta = \left( \frac{d y_n}{D} \right)$$

For bright spot  $\frac{y_n d}{D} = n\lambda \rightarrow$  These fringes are non localized, can be seen on screen, as well as through eye piece. They can be photographed by just placing a film on the screen.

$$\Rightarrow y_n = n \left( \frac{D\lambda}{d} \right)$$

$$y_{n+1} = (n+1) \left( \frac{D\lambda}{d} \right)$$

$$\Rightarrow \text{Fringe Width} = \beta = y_{n+1} - y_n = \left( \frac{D\lambda}{d} \right)$$

$$y_n \text{ dark} = (n - \frac{1}{2}) \left( \frac{D\lambda}{d} \right)$$

$\Rightarrow$  Alternative dark and bright patterns are produced.  
or fringes

★ They appear to be flat but actually hyperbolic in shape.  
[due to cutting of hyperboloid by 2-d sheet].

From the coordinates marked in last figure.

$$S_2 P = S_1 P + \Delta$$

$$x^2 + \left(y + \frac{d}{2}\right)^2 + D^2 = \left[ \sqrt{x^2 + \left(y - \frac{d}{2}\right)^2 + D^2} + \Delta \right]^2$$

$$2yd = \Delta^2 + 2\Delta \sqrt{x^2 + \left(y - \frac{d}{2}\right)^2 + D^2}$$

$$\left( \frac{2yd - \Delta^2}{2\Delta} \right) = \sqrt{x^2 + \left(y - \frac{d}{2}\right)^2 + D^2}$$

$$\Rightarrow x^2 + \left(y - \frac{d}{2}\right)^2 + D^2 = \left(\frac{yd}{\Delta} - \frac{\Delta}{2}\right)^2$$

$$x^2 + y^2 + \frac{d^2}{4} - yd + D^2 = \frac{y^2 d^2}{\Delta^2} + \frac{\Delta^2}{4} - yd$$

$$x^2 - y^2 \left[ \frac{d^2}{\Delta^2} - 1 \right] = \left[ \frac{\Delta^2}{4} - \frac{d^2}{4} - D^2 \right]$$

$$\uparrow \oplus \left( \frac{1}{\sin^2 \theta} - 1 \right)$$

$$\uparrow \ominus$$

\* For a given  $\Delta$ , it is a hyperbola

$$\Rightarrow \frac{y^2}{A} - \frac{x^2}{B} = 1$$

$$\Rightarrow \text{Hyperbolic} \quad \left[ \frac{y^2}{A} - \frac{x^2}{B} = 1 \right]$$

form of IIT

But appear to be straight

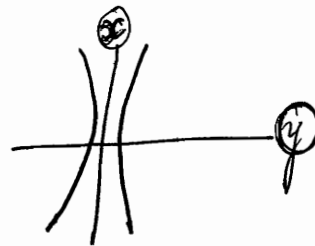

Use of interference:

- 1) To determine  $\lambda$  of wave.
- 2) To determine  $\mu$  of medium.

$$\mu = \frac{c}{v}$$

$$v = \left( \frac{c}{\mu} \right)$$

out of  $\lambda, \nu, v$ : only 2 are independent,

→ If  $\lambda$  known,  $\mu$  is known

⇒  $\lambda, \nu, \nu$  can be determined

**determination of  $\lambda$**



We know,  $\beta = \frac{D\lambda}{d} \Rightarrow \lambda$  can be calculated from measurement of  $\beta$ ,  $d$  and  $D$ .

### determination of $\mu$

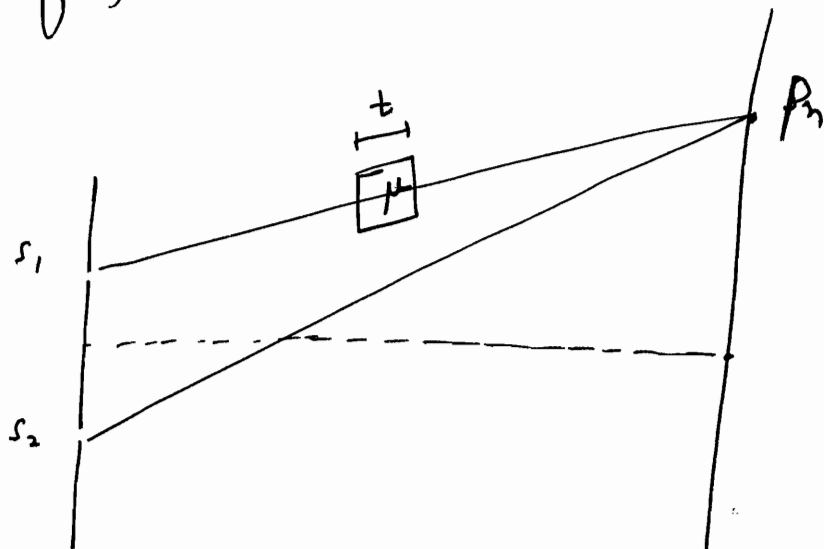

$$S_2P - S_1P = \frac{y_n^* d}{D}$$

In absence of film,  $y_n = n \left( \frac{D\lambda}{d} \right)$

$$S_1P_n^* = S_1P_n + (\mu - 1)t$$

$S_2P - S_1P^* = n\lambda$  for  $n^{\text{th}}$  bright fringe

$$= \frac{S_1P_n + (\mu - 1)t}{c}$$

$$S_2P - S_1P - (\mu - 1)t = n\lambda$$

$$S_2P - S_1P = n\lambda + (\mu - 1)t$$

$$\Rightarrow \frac{y_n^* d}{D} = n\lambda + (\mu - 1)t$$

$$\Rightarrow y_n^* = \frac{nD\lambda}{d} + (\mu - 1)t \left( \frac{D}{d} \right)$$

$$\Rightarrow \boxed{y_n^* = y_n + \frac{(\mu - 1)t D}{d}}$$

~~$$S_1P - S_2P = \frac{-dy_n}{D} = n\lambda$$~~

$$S_1P + (\mu - 1)t - S_2P = \frac{-dy_n^*}{D} = n\lambda$$

$$\Rightarrow (\mu - 1)t = \frac{-d}{D} (y_n^* - y_n)$$

$$\Rightarrow y_n^* = y_n + \frac{D}{d} t (\mu - 1)$$

or

$$(\mu - 1)t = (n_1 - n_2)\lambda = k\lambda$$

$$\Rightarrow \mu = \left[ \frac{k\lambda}{t} + 1 \right]$$

$$\text{time taken} = \frac{S_1P_n - t}{c} + \frac{t}{c} \mu$$

$$\text{OPTICAL PATH} = c * \text{time taken}$$

$$= S_1P_n + (\mu - 1)t$$

⊛  $(y_m^* - y_m)$  measurement gives  $\mu$ .

$$\text{Shift of Fringe Pattern} = \frac{D}{d} (\mu - 1) t$$

say  $k$  fringes shifted upwards

$$\Rightarrow k\beta = \boxed{\frac{\beta}{\lambda} (\mu - 1) t} \quad \checkmark$$

$$\Rightarrow \frac{k\lambda}{t} + 1 = \mu$$

- ⊙ If inserted in upper path, upper shift
- ⊙ If inserted in lower path, lower shift

⊛ Note that in order to know the position of central fringe, we use white light

[P-14-15 Ghatak]

⊛ जिस तरफ  $(\mu - 1)t$  वाली plate लगाओगे, उस तरफ fringes shift कर जाएंगी !!

Fringe shift up means fringe number from central fringe will reduce....

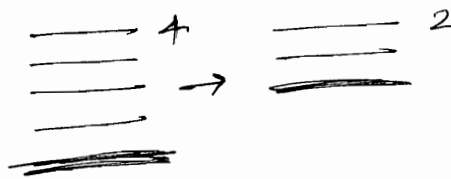

अगर central fringe ' $k$ ' fringes ऊपर shift कर गईं

$$\Rightarrow d \sin \theta = (\mu - 1) t$$

$$\Rightarrow \frac{d \cdot k \cdot \lambda}{D} = (\mu - 1) t$$

$$\Rightarrow \boxed{\frac{k\lambda}{t} + 1 = \mu}$$

⊛

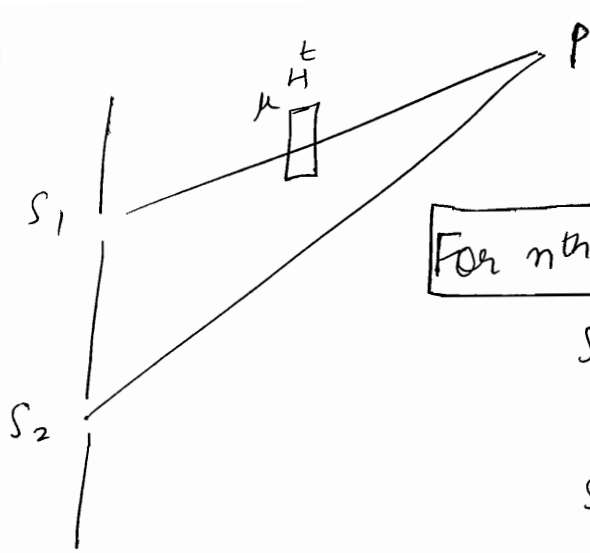

For  $n^{\text{th}}$  fringe

$$S_2P - S_1P = d \sin \theta = \frac{d y_n}{D}$$

$$S_2P_1 - S_1P^* = d \sin \theta^* = \frac{d y_{n^*}}{D}$$

$$S_1P^* - S_1P = \frac{d}{D} (y_n - y_{n^*})$$

$$\Rightarrow (\mu - 1)t = \frac{d}{D} (y_n - y_{n^*})$$

$$\Rightarrow \mu = \frac{d \Delta y}{Dt} + 1$$

Let  $k$  fringe shift upwards,

$$\Rightarrow \Delta y_n = k\beta = k \cdot \frac{\lambda D}{d}$$

$$\Rightarrow \mu = \frac{d}{Dt} \cdot \frac{k\lambda D}{d} + 1 = \frac{k\lambda}{t} + 1$$

$$\Rightarrow \mu = \frac{k\lambda}{t} + 1$$

⊛

In sound waves, interference is observed without much difficulty b'coz the interfering waves maintain a constant phase relationship.

However for light waves, due to the very process of emission, one cannot observe interference between the waves from two independent sources, although interference does take place. Thus one tries to derive interfering waves from a single wave so that phase

Relationship is maintained.

The methods to achieve this are classified under two categories :

- ① Division of wavefront
- ② Division of Amplitude

★ In an interference pattern, locus of points which correspond to minima are known as Nodal lines.

### Location of Central Fringe

In the usual interference pattern with a nearly monochromatic source (like a sodium lamp), a large number of interference fringes are obtained and it's extremely difficult to determine the position of the central fringe. It can be determined using white light as a source.

When slit is illuminated with white light, the central fringe produced at point O will be white b'coz all wavelengths will constructively interfere here. We can put a crosshair & fix it here. Above and below the central spot fringes will be coloured due to different paths of different colours. Although the colour soon fades to white at distance far from central fringe on both sides. This is because, for example, at point P'  $S_2P' - S_1P' = 30 \times 10^{-5} \text{ cm}$  (high value), wavelengths corresponding to this path difference will interfere. These will be

Red:  $7.5 \times 10^{-5}$   
green  $5 \times 10^{-5}$   
yellow  $6 \times 10^{-5}$   
violet  $4.3 \times 10^{-5}$

Colour of such light will appear as ~~white~~ white.

# OPTICS (8)

## Fresnel's Biprism

In prism deviation is minimum if  $\delta = (\mu - 1)A$

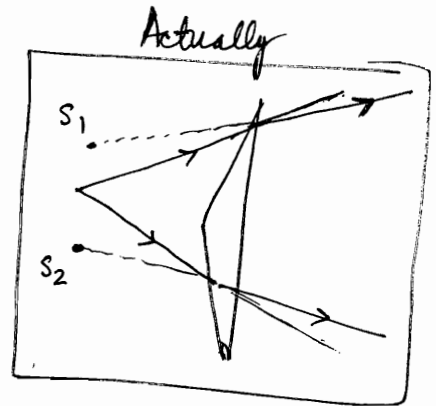
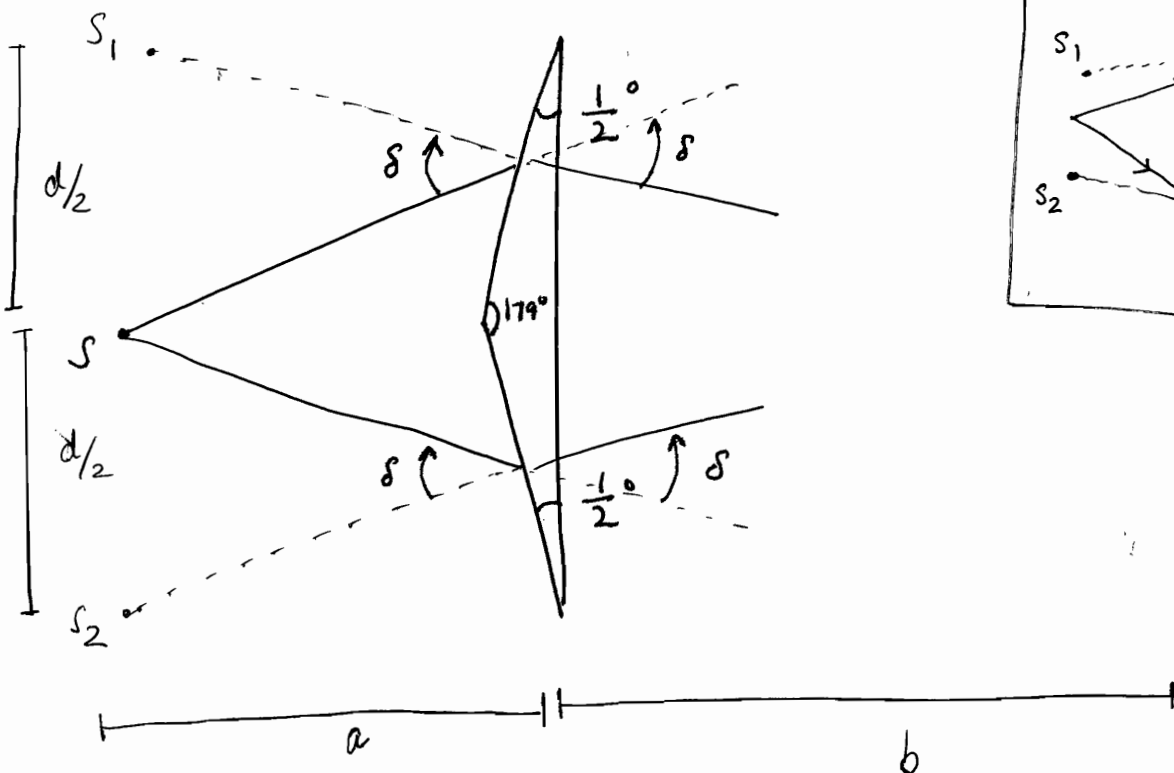
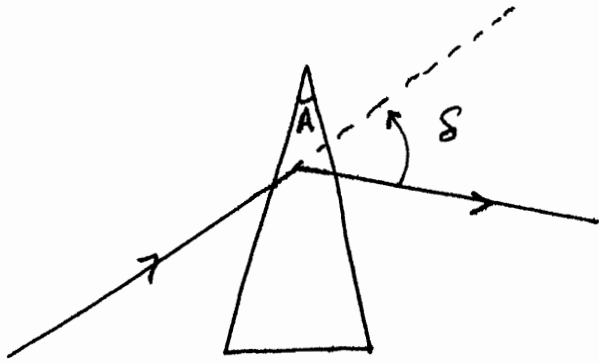

$S_1$  and  $S_2$  are coherent.

$$D = a + b$$

$$d = d/2 + d/2 = d$$

Now the diagram is equivalent to

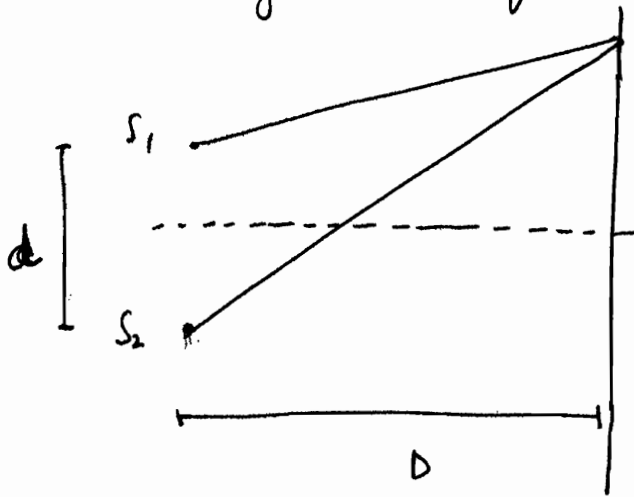

$$\checkmark y_n = n \left( \frac{D\lambda}{d} \right)$$

$$\checkmark \beta = \left( \frac{D\lambda}{d} \right)$$

Fresnel Biprism is used in laboratory to measure  $\mu$  &  $\lambda$ , instead of young's double slit apparatus.

$$\delta = (\mu - 1) A$$

$$\delta \approx \frac{d}{2a}$$

$$\Rightarrow \boxed{d = 2a(\mu - 1) A}$$

Analytical Method to determine  $d$

Geometrical Method to determine  $d$

$$d = \sqrt{d_1 d_2}$$

$d_1, d_2$  : distance of formation of 2 images

# Interference due to division of Amplitude

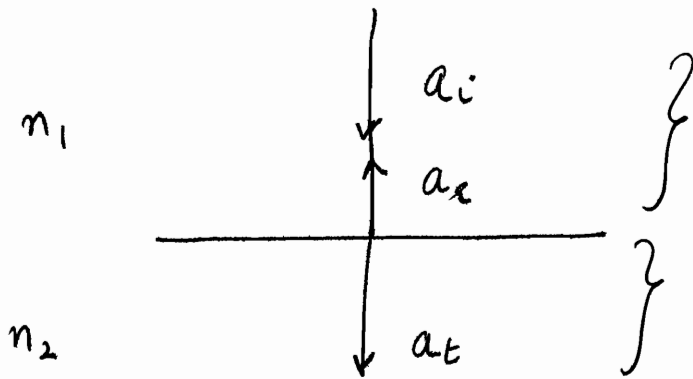

$$a_r = \left( \frac{n_2 - n_1}{n_1 + n_2} \right) a_i$$

$$a_t = \left( \frac{2n_1}{n_1 + n_2} \right) a_i$$

$$a_i + a_r = a_t$$

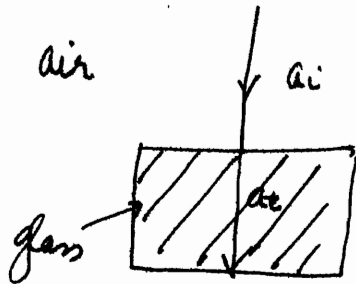

$$a_r = \frac{1 - 1.5}{1 + 1.5} = \frac{-0.5}{2.5} = -0.2 a_i$$

$$a_t = \frac{2 \cdot 1}{1 + 1.5} = \frac{2}{2.5} = 0.8 a_i$$

- Extended source of light is used in division of Amplitude interference to view larger area of film, unlike point source in wavefront division.
- lighter to denser medium: Phase difference of  $\pi$  in reflected wave.

Examples :-

do P-14-12

Colours produced due to thin film

→ example formation of beautiful colours produced by a soap film

$$a_1 = -0.2 a_i$$

$$a_2 = 0.8 a_i$$

$$a_3 = \frac{1.5 - 1}{1.5 + 1} a_2 = 0.16 a_i$$

$$a_4 = \frac{2 \cdot 1.5}{2.5} a_2 = 0.96 a_i$$

$$a_5 = 0.032 a_i$$

$$a_6 = 1.2 \times 0.16 a_i = 0.192 a_i$$

⊗ Only ① will suffer phase difference of  $\pi$   
 $\mu_1 = 1$

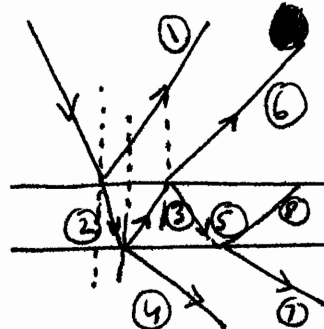

→ from within the film, only minute amount is reflected, rest all is transmitted.

$$a_7 = 1.2 \times 0.032 = 0.0384 a_i$$

→ We prefer reflected light as fringes have better contrast due to similar intensities.

→ In transmitted light, huge difference in intensities, hence not good fringes observed.

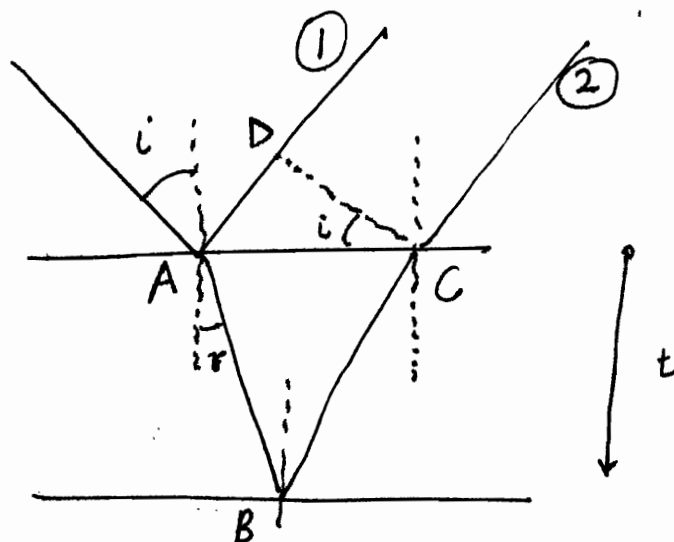

$$AB \cos r = t$$

$$AD = AC \sin i$$

$$= \frac{2AB \sin r \sin i}{\cos r}$$

$$= 2t \tan r \sin i$$

$$\Delta = \left[ \mu (AB + BC) \right] - \left[ AD + \frac{\lambda}{2} \right]$$

$$= \frac{\mu \cdot 2 \cdot t}{\cos r} - \frac{2t \tan r \sin i}{\cos r} - \frac{\lambda}{2}$$

$$= \frac{2\mu t}{\cos r} \left[ 1 - \sin^2 i \right] - \frac{\lambda}{2}$$

$$\boxed{\begin{aligned} \mu \sin r &= \sin i \\ &= \sin^2 i \end{aligned}}$$

$$\Rightarrow \boxed{\Delta = 2\mu t \cos r - \frac{\lambda}{2}}$$

⊙ it can also be

$2\mu t \cos r + (\lambda/2)$   
depending upon which is hard surface



For transmitted light

P-15.13

Point source

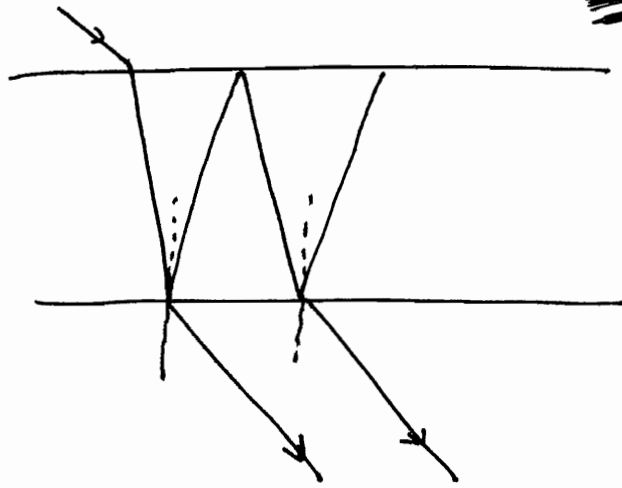

Film

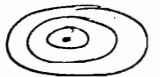

Eye

dark or bright depending on position of eye.

Extended source

Film

No pattern

Eye focussed at  $\infty$

dark/bright ring Haidinger rings.

$$\Delta = 2\mu t \cos r$$

← Note that patterns are observed w/o varying anything either 'r' or 't'.....

In reflected light,

$$\Delta = 2\mu t \cos r - \frac{\lambda}{2} = n\lambda$$

Maxima

$$\Rightarrow 2\mu t \cos r = \left(n + \frac{1}{2}\right) \lambda$$

← Written like this for  $n=1, 2, 3, \dots$

$$\Delta = 2\mu t \cos r - \frac{\lambda}{2} = \left(n - \frac{1}{2}\right) \lambda$$

Minima

for  $n=0, 1, 2, \dots$

$$\Rightarrow 2\mu t \cos r = n\lambda$$

Hence, central spot in reflected light is dark.

also we can vary  $t$  i.e.  $\frac{\lambda}{2\mu \cos r}, \frac{2\lambda}{2\mu \cos r}$

In transmitted light,

$$2\mu t \cos r = n\lambda \quad \text{for Maxima}$$

$$2\mu t \cos r = \left(n - \frac{1}{2}\right) \lambda \quad \text{for Minima}$$

Let us consider the condition,

$$2\mu t \cos r = n\lambda \quad \dots \dots \mu, \lambda \text{ are fixed}$$

$t, r, n$  are variable

There can be 2 types of fringes:

एक  $\lambda$  के लिए 1 fringe... दूसरे  $\lambda$  के लिए दूसरी fringe!!!!

i) Fringes of constant inclination [t is const.]

ii) Fringes of constant thickness  
एक thickness के लिए fringe... दूसरी thickness के लिए दूसरी fringe !!

### Const. inclination FRINGE

• Thickness of film t is const.

$t, \mu, \lambda$  are fixed

⇒ for a given  $n$ ,

$$\cos r_1 = \left(\frac{\lambda}{2\mu t}\right)$$

Order is determined

eg. Michaelson Interferometer  
Fabry Perot Interferometer

### Const. thickness FRINGE

• Thickness of film is variable

We make r fixed, like normal incidence.

$$t = \frac{\lambda}{2\mu \cos r}$$

eg. Newton's Rings

Wedge Shaped Films

• locus is ring / circle or straight lines.

All points on screen having  
1 particular value of incidence  
will give fringes of 1 particular  
order.

Locus of such points is circle.

Its called **HARDINGER'S RINGS**

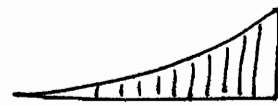

variable  $t$   
It will  
const. thickness  
fringe.

- Particular value of  $t$  will  
give particular order  
of fringes.

### Reflectivity

$$\frac{S_r}{S_i} = \left(\frac{A_r}{A_i}\right)^2 = \left(\frac{n_1 - n_2}{n_1 + n_2}\right)^2$$

Makes  
sense also.....

$\mu$  को बढ़ाने से  
reflectivity बढ़ेगी

$$\left|\frac{S_r}{S_i}\right| \propto \left(\frac{n-1}{n+1}\right) = 1 - \left(\frac{2}{n+1}\right)$$

$n \uparrow \Rightarrow \left(\frac{-2}{n+1}\right) \uparrow \Rightarrow \left(\frac{S_r}{S_i}\right) \uparrow$

$S$ : intensity

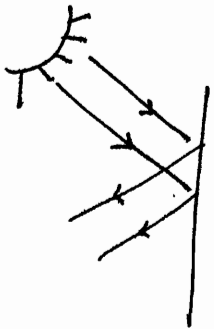

light reflected =  $\left(\frac{0.5}{2.5}\right)^2 = \underline{4\%}$

$\Rightarrow$  light entering the car = 96%

We can play with  $n_2$  to increase/decrease reflectivity.

### Non-Reflecting Films

① To make non-reflecting  $n_2 \downarrow$

$I^2 \Rightarrow (0.5)^2$  ~~is~~  
 $\Rightarrow$  latter is non-reflecting

We put a film over glass

$MgF_2$  (magnesium fluoride)

Coating  $\mu_{MgF_2} = 1.3 \Rightarrow \left(\frac{S_r}{S_i}\right) = \left(\frac{0.3}{2.3}\right)^2 = \underline{1.7\%}$

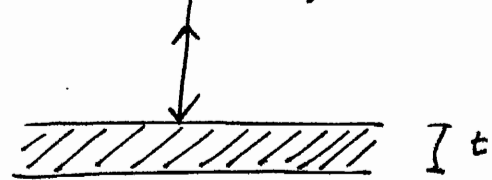

We also have to choose  $t$ .

✓  $\lambda/2$  path difference for both

→  $\Delta = 2n_1 t \cos r$

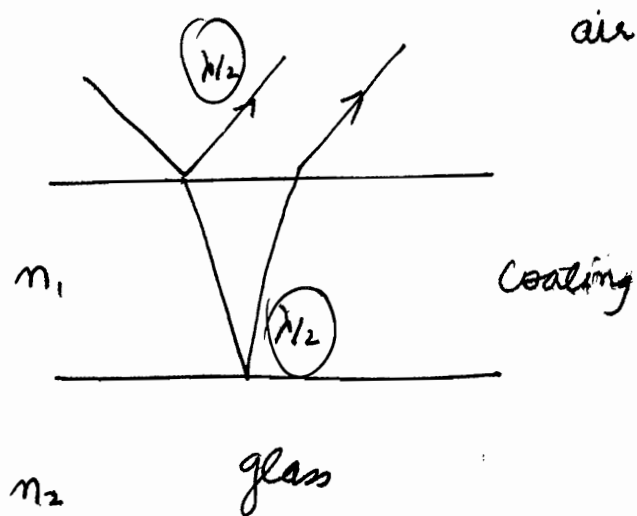

For non-reflecting

$2n_1 t \cos r = (n - \frac{1}{2}) \lambda$  : Condition for dark spot

$t = \frac{(n - \frac{1}{2}) \lambda}{2\mu_1 \cos r}$

$= \frac{(n - \frac{1}{2}) \lambda}{2\mu_1}$

for normal incidence

⇒  $t = \frac{\lambda}{4\mu_1}, \frac{3\lambda}{4\mu_1}, \frac{5\lambda}{4\mu_1}, \dots$

$t = \frac{(2n-1) \lambda}{4\mu}$

Q | light:  $5200 \text{ \AA}$

MgF<sub>2</sub>:  $\mu = 1.3$

$t_{\text{sheet minimum}} = 4500 \text{ \AA}$

⊛ Reducing reflectivity is called Blooming.

AI  $t = (n - \frac{1}{2}) \cdot \frac{5200}{2 \cdot 1.3} = (n - \frac{1}{2}) \cdot 2000$

⇒  $t$  can be = 1000, 3000, 5000

Now  $t_{\text{minimum}} = \underline{\underline{5000 \text{ \AA}}}$

# Reflecting Films

To increase reflectivity,  $n \uparrow$  (Titanium Dioxide)  
 $n = 2.4$

air

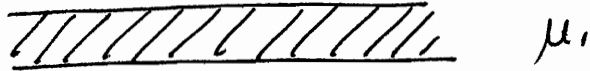

$$\mu_1 > \mu_{\text{glass}}$$

glass

$$\mu_1 = 2.62$$

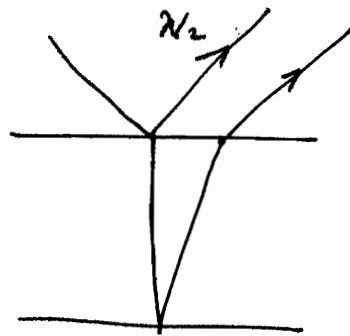

$$\Delta = 2n_1 t \cos r - \frac{\lambda}{2}$$

For increasing reflectivity, spot should be bright ★

$$\Rightarrow 2n_1 t \cos r - \frac{\lambda}{2} = n\lambda$$

$$\Rightarrow 2n_1 t \cos r = \left(n + \frac{1}{2}\right) \lambda$$

For  $t_{\text{minimum}}$ ,  $\cos r = 1$

$$\Rightarrow t = \frac{\left(n + \frac{1}{2}\right) \lambda}{2\mu_1}$$

$n = 0, 1, 2, \dots$

$$t = \frac{\lambda}{4\mu_1}, \frac{3\lambda}{4\mu_1}, \dots$$

$$t = \frac{(2m-1)\lambda}{4\mu_1} \quad m = 1, 2, 3, \dots$$

# Fringes of constant thickness

- $r$  fixed
- $t$  variable

Variable thickness films are used.

## Wedge Shaped Films

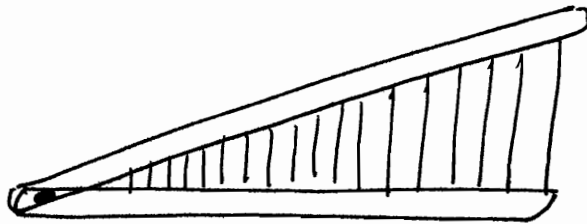

eg. 2 wooden planks: Film in between.....

$t=0$  at edge of the wedge

⊙ Wooden planks are placed just to demonstrate the shape of film.

Actually

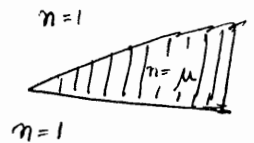

Let us have normal incidence

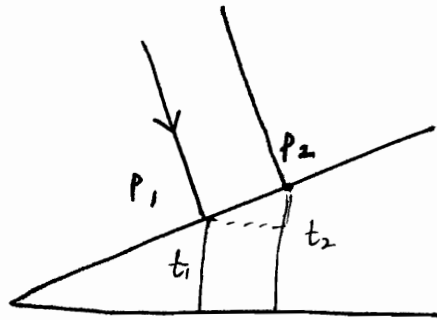

Locus is straight fringes parallel to edge of the wedge.

Let at  $t_1, t_2$ : 2 bright fringes

$$\theta = \left( \frac{t_2 - t_1}{\beta} \right)$$

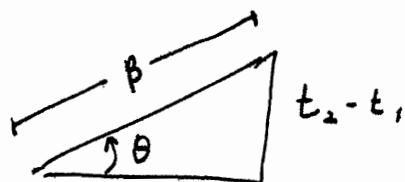

@ P<sub>1</sub> : bright fringe  $\Rightarrow \Delta = n\lambda$

$$\boxed{2\mu t_1 - \frac{\lambda}{2}} = n\lambda$$



reflection from hard surface

$$\Rightarrow 2\mu t_1 = \left(n + \frac{1}{2}\right)\lambda$$

For next bright fringe at P<sub>2</sub>

$$2\mu t_2 = \left(n + \frac{3}{2}\right)\lambda$$

$$\Rightarrow \boxed{t_2 - t_1 = \frac{\lambda}{2\mu}}$$

$$\boxed{\theta = \frac{\lambda}{2\mu\beta}}$$

Beautifully explained on P-15.15 of Ghatak

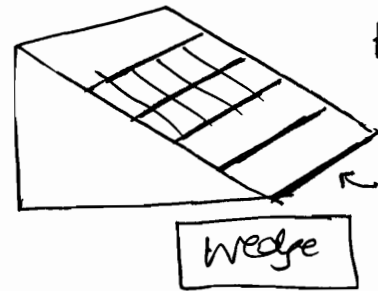

Fringes are || to edge of wedge

← edge of wedge

< Refer end of notes for Wedge shaped Films > Also

Q12) 2004 / 20 marks

$$\lambda_{\text{light}} = 500 \text{ nm}$$

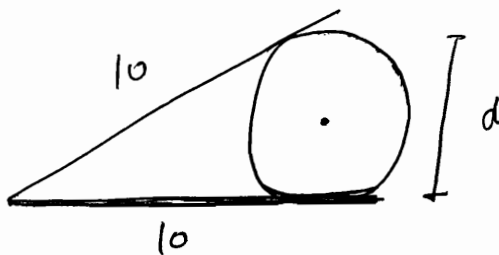

$$\theta = \frac{\lambda}{2\mu\beta} = \frac{\lambda}{2\beta} \quad (\mu=1)$$

$$\Rightarrow \frac{d}{10} = \frac{500 \text{ nm}}{2 \cdot 1.25 \text{ mm}} = \frac{5000 \times 10^{-10}}{2 \times 1.25 \times 10^{-3}} = \frac{5000 \times 10^{-7}}{2.5}$$

$$\Rightarrow d = \frac{50000 \times 10^{-6}}{25} = 2 \times 10^{-3} = \underline{\underline{2 \text{ mm}}}$$

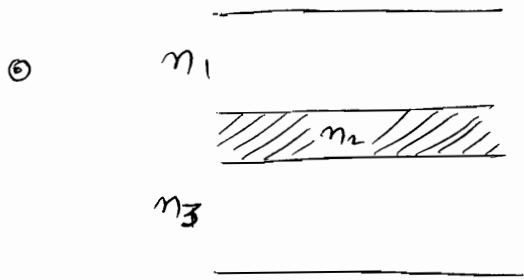

if  $n_1 < n_2 < n_3$   
बीच का  $\Rightarrow$  Anti Reflecting Film

if  $n_2 > n_1$  and  $n_2 > n_3$   
or  
सबसे छोटा  $n_2 < n_1$  and  $n_2 < n_3$   
या  
सबसे बड़ा  $\Rightarrow$  More reflecting film

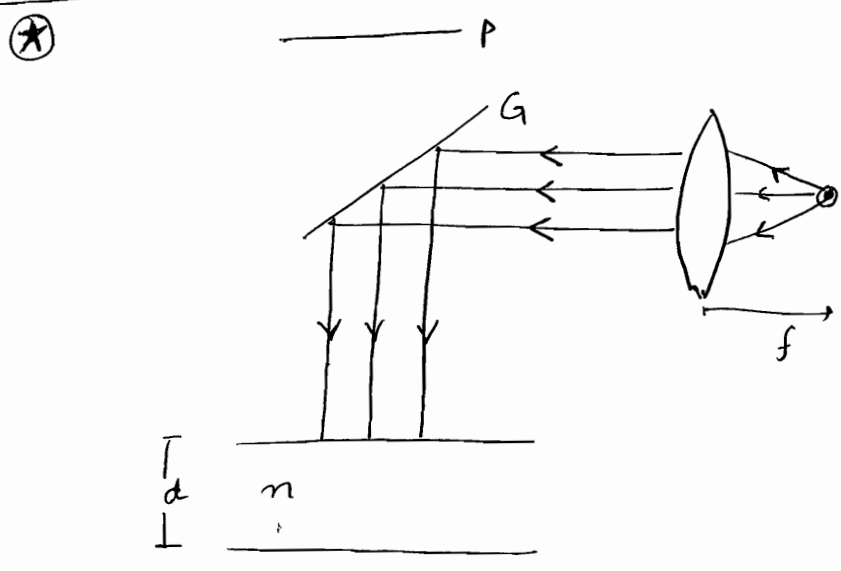

In order to observe the interference pattern w/o obstructing the incident beam, we use a partially reflecting plate G. Such an arrangement also enables us to eliminate the direct beam from reaching the eye or photographic plate P. Besides, it gives normal incidence.

The applications of thin film interference phenomenon in reducing the reflectivity of lens surface is very known. In many optical instruments, like telescope, there are many interfaces and loss of intensity due to reflections can be severe.

The technique of reducing the reflectivity is called BLOOMING

To develop anti reflecting film for  $\lambda = 6000 \text{ \AA}$ , the thickness could be  $(2n-1) \frac{\lambda}{4\mu}$   
 $= 1224.7 \text{ \AA}$ ,  $3674.2 \text{ \AA}$ , .....  
 $(t_1)$   $(t_2)$

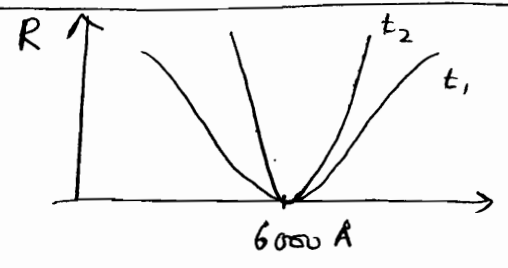

As shown in graph, for least  $t$ , minimum is broad and reflectivity small for entire range of visible spectrum. Thus for anti reflecting coating, smallest film thickness is preferred.



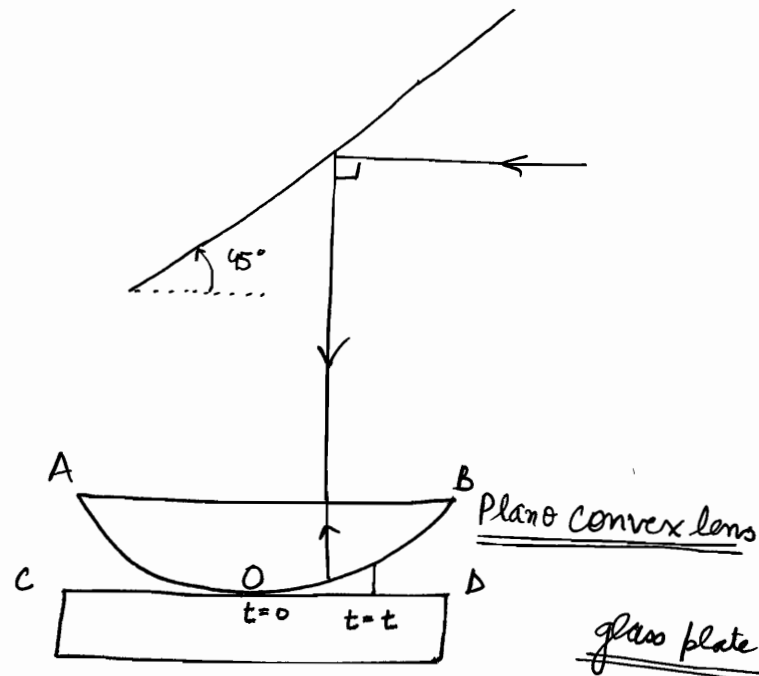
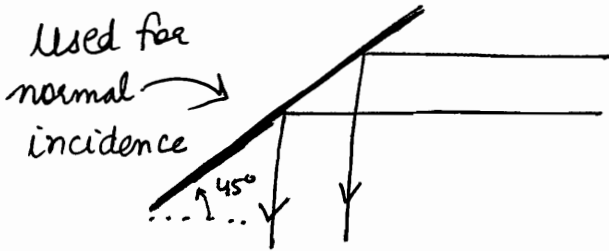

## Newton's Rings

○ We are interested in interference between reflection from AOB and reflection from COD

1<sup>st</sup> Reflection: no shift

2<sup>nd</sup> Reflection: air to glass to air  $\Rightarrow \pi$  shift or  $(\frac{\lambda}{2})$  shift

○ Corresponding to the edge of the wedge, here we have got circular periphery for a constant  $t$ ... hence rings formed... called Newton's Rings

$$\Delta = 2\mu t \cos r + \frac{\lambda}{2}$$

Note that  $\mu$  is refractive index of film

For maxima :  $2\mu t \cos r + \frac{\lambda}{2} = n\lambda$

$$\Rightarrow 2\mu t \cos r = (2n-1) \frac{\lambda}{2} \quad n=1,2,3,\dots$$

$$\Rightarrow t = \frac{(2n-1)\lambda}{4\mu}$$

For dark fringe :  $2\mu t \cos r = n\lambda \quad n=0,1,2,\dots$

$$\Rightarrow t = \frac{n\lambda}{2\mu}$$

At  $t=0, n=0 \Rightarrow$  Central ~~fringe~~ spot is dark

Fringes are circular in shape

Central spot is not considered a ring. 1<sup>st</sup> dark ring comes after that.

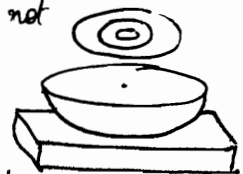

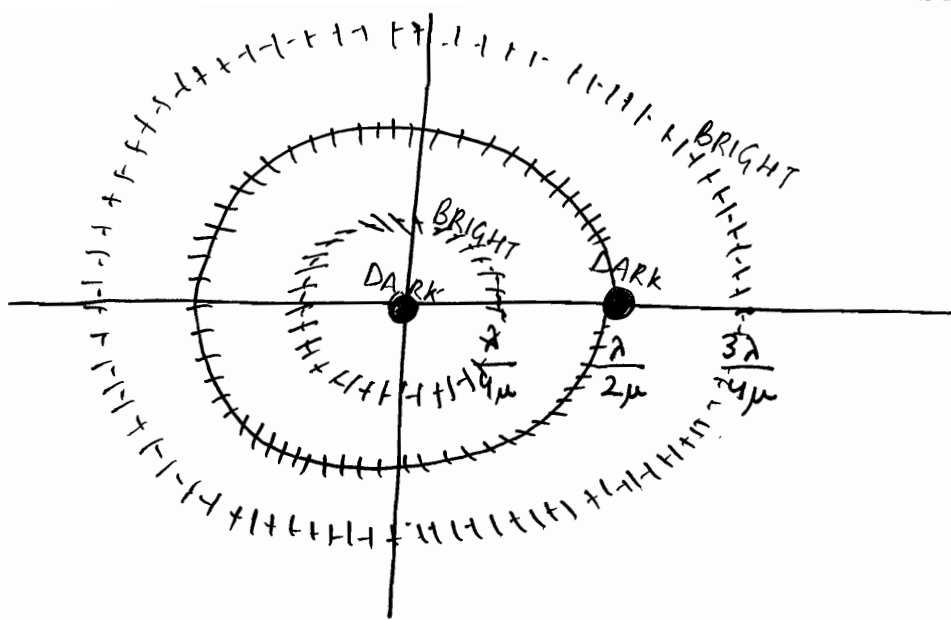

We have to find out diameter of fringes at  $n^{\text{th}}$  bright or dark.

Using segment theorem of geometry :-

$$t(2R-t) = \left(\frac{d_n}{2}\right)^2$$

$$\Rightarrow t = \left(\frac{d_n^2}{8R}\right)$$

where  $d_n$ : diameter of  $n^{\text{th}}$  fringe

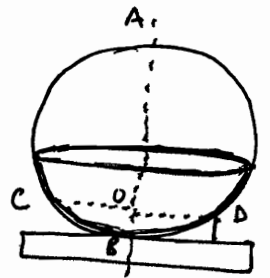
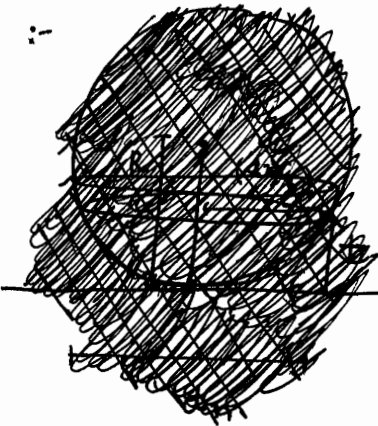

$$AO * OB = CO * OD$$

$$\Rightarrow (2R-t)t = \frac{d_n}{2} \times \frac{d_n}{2}$$

$$\Rightarrow t(2R-t) = \frac{d_n^2}{4}$$

Dark rings

$$2\mu t = n\lambda$$

$$2\mu \cdot \frac{D_n^2}{8R} = n\lambda$$

$$\Rightarrow \boxed{D_n^2 = \left(\frac{4n\lambda R}{\mu}\right)}$$

air :  $D_n^2 = \frac{4n\lambda R}{\mu} = (4\lambda R n)$

$\mu$  :  $(D_n)_{\text{med}}^2 = \frac{4n\lambda R}{\mu} = \left[\frac{D_n^2}{\mu}\right]_{\text{air}}$

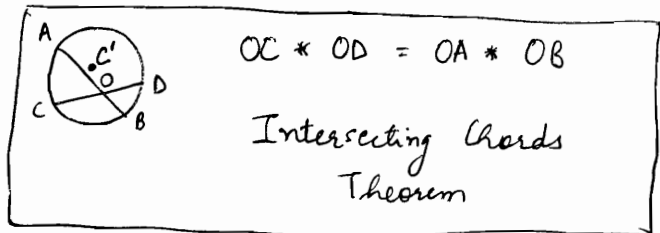

$$OC * OD = OA * OB$$

Intersecting Chords Theorem

$$n=0, 1, 2, 3, \dots$$

$D_n$ : diameter of fringe

$$D_n \text{ medium} = \frac{D_n \text{ air}}{\sqrt{\mu}}$$

Remember  $\mu=1$  in Newton rings

$\Rightarrow$  diameters of fringes are reduced in other medium of film.

Fixed a cross wire on dark ring.

$$D_n^2 = 4n\lambda R \quad \text{in air}$$

$$D_{n+p}^2 = 4(n+p)\lambda R$$

$$D_{n+p}^2 - D_n^2 = 4\lambda R p$$

$$\lambda = \frac{D_{n+p}^2 - D_n^2}{4pR}$$

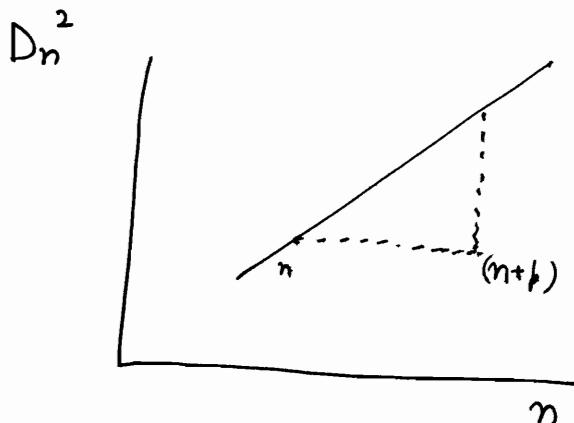

Even with Newton rings we can have spectral width determination

$$2\mu t = (n - \frac{1}{2})\lambda_1 = n\lambda_2$$

(Condition of disappearance)

$$\Rightarrow \frac{2\mu t}{\lambda_2} - \frac{2\mu t}{\lambda_1} = \frac{1}{2}$$

$$\Rightarrow \Delta\lambda = \frac{\lambda^2}{4\mu t}$$

For Bright Ring

$$2\mu t = (n - \frac{1}{2})\lambda$$

$$(D_n^2)_{\text{bright}} = \frac{4(n - \frac{1}{2})\lambda R}{\mu}$$

$n=1, 2, 3, \dots$

Extended source is used to view larger area of the film.

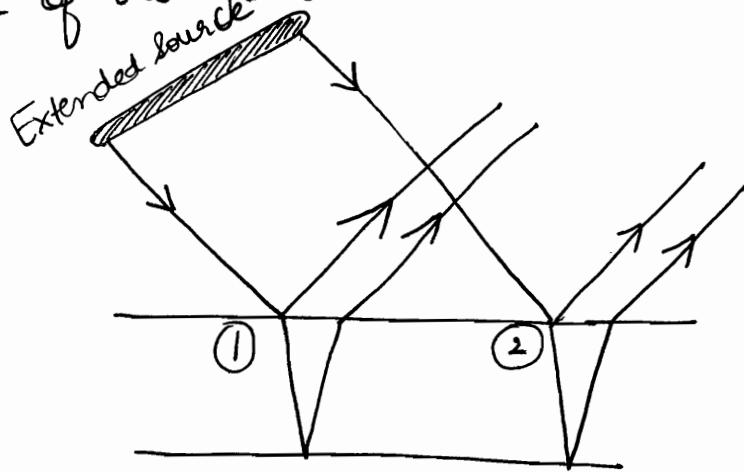

$$\frac{a}{b} = \frac{k}{1}$$

$$\frac{a+b}{a-b}$$

$$= \frac{kb+b}{kb-b} = \frac{(k+1)}{(k-1)}$$

If we had used single point source,  $A$  reduces in  $(2)^{\text{nd}}$  interference and hence not proper fringes are observed.

Q16)  $E_1 = 2 \cos \left( \vec{R}_1 \cdot \vec{\partial} - \omega t + \frac{\pi}{3} \right)$

$$E_2 = 5 \cos \left( \vec{R}_2 \cdot \vec{\partial} - \omega t + \frac{\pi}{4} \right)$$

Intensity  
 $I_{\text{max}}$

$$= \frac{1}{2} C \epsilon_0 A^2 \Rightarrow I_1 = \frac{1}{2} C \epsilon_0 (4)$$

$$I_2 = \frac{1}{2} C \epsilon_0 (25)$$

$$I_{12} = I_1 + I_2 = 2\sqrt{I_1 I_2} \cos(\phi)$$

$$\phi = \frac{2\pi}{\lambda} \cdot \Delta$$

$$V = \frac{I_{\text{max}} - I_{\text{min}}}{I_{\text{max}} + I_{\text{min}}}$$

$$I_{\text{max}} = (\sqrt{I_1} + \sqrt{I_2})^2$$

$$I_{\text{min}} = (\sqrt{I_1} - \sqrt{I_2})^2$$

$$\text{Visibility Parameter} = \frac{I_{\max} - I_{\min}}{I_{\max} + I_{\min}}$$

$$\Rightarrow V = \frac{(\sqrt{I_1} + \sqrt{I_2})^2 - (\sqrt{I_1} - \sqrt{I_2})^2}{(\sqrt{I_1} + \sqrt{I_2})^2 + (\sqrt{I_1} - \sqrt{I_2})^2}$$

$$V = \frac{2\sqrt{I_1 I_2}}{I_1 + I_2}$$

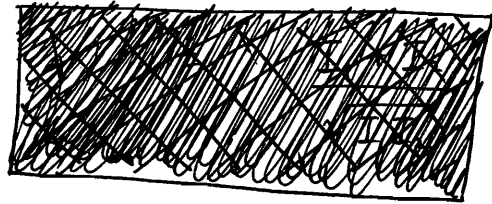

$$V = \frac{2\sqrt{I_1 I_2}}{I_1 + I_2}$$

Michelson's Interferometer :- Fringes of Constant Inclination (1887)

$\mu, \lambda, t$  are const.

1 angle of incidence will give 1 particular order fringes.

The locus is called Haidinger Rings.

### Applications

- 1) determination of  $\lambda$
- 2) determination of  $\mu$
- 3) Spectral width of light source
- 4) Standardization of meter scale
- 5) determination of purity of spectral line : (Coherence length)

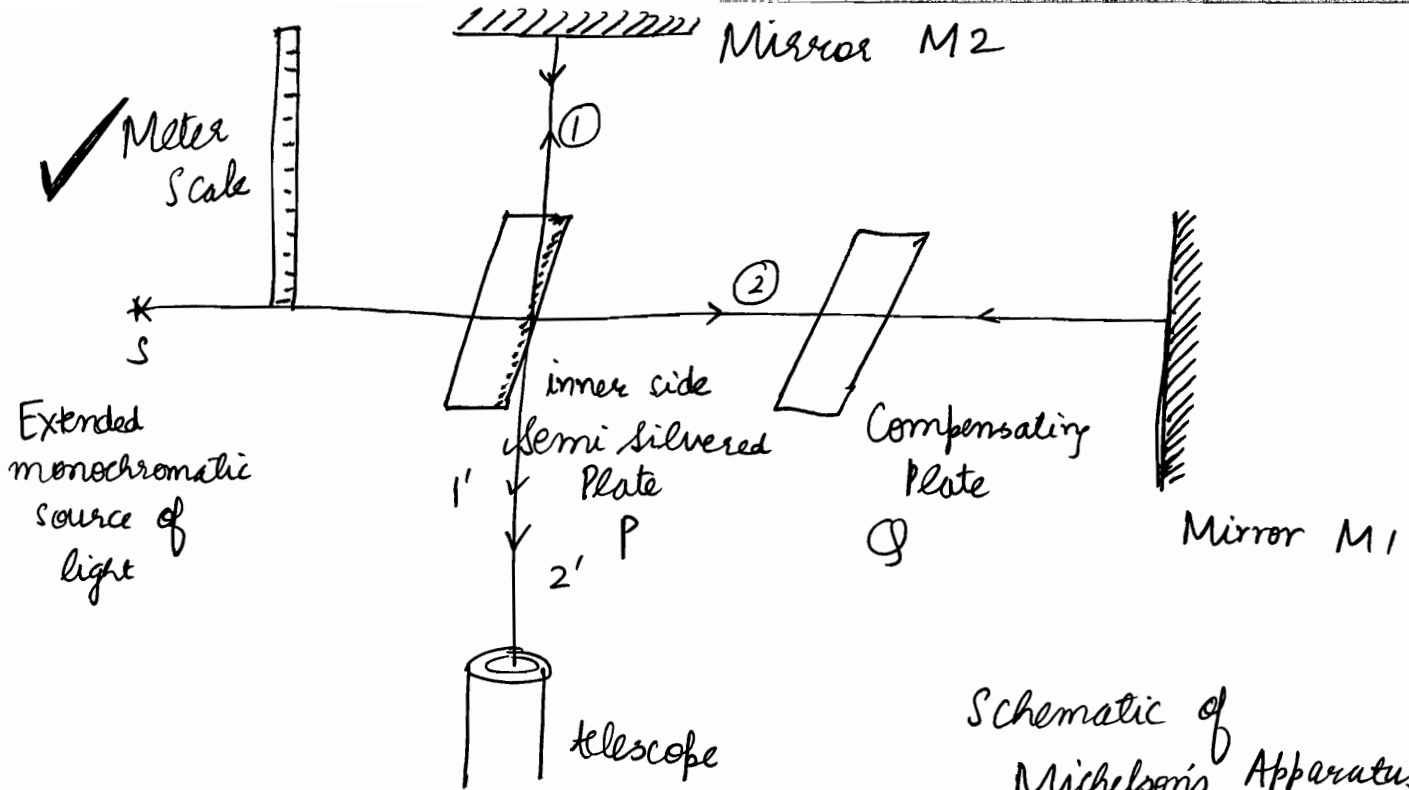

Schematic of Michelson's Apparatus

$M_1$  is fixed  
 $M_2$  is movable

⊕ Since extended source is used, no pattern is observed on photographic plate but circular patterns corresponding to different inclinations are seen with a camera focussed at  $\infty$ .

- Haidinger's rings are observed when viewed from telescope.
- $M_1'$  is  $\perp$  to  $M_1$  which is fixed.

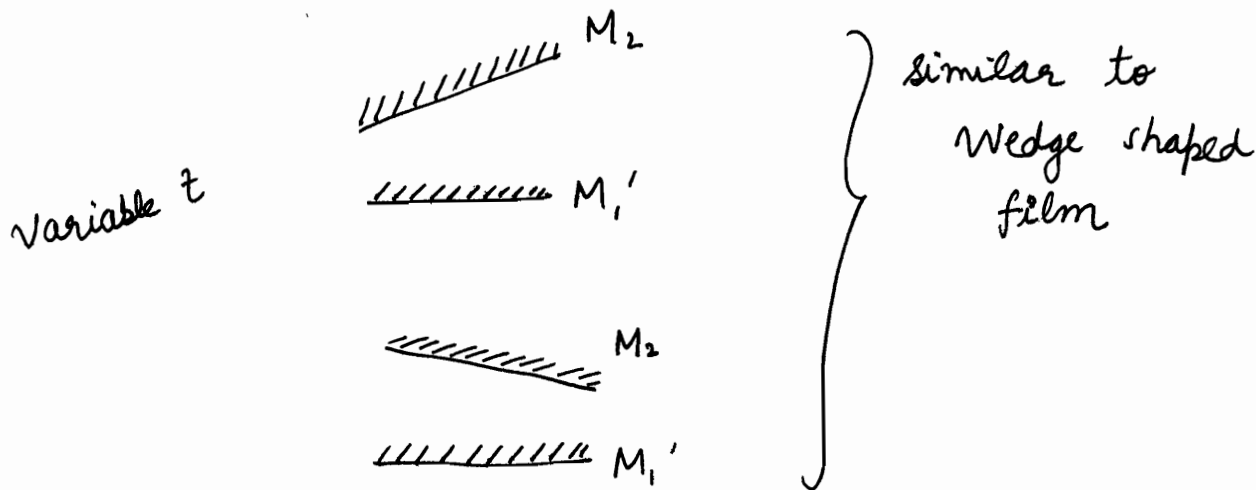
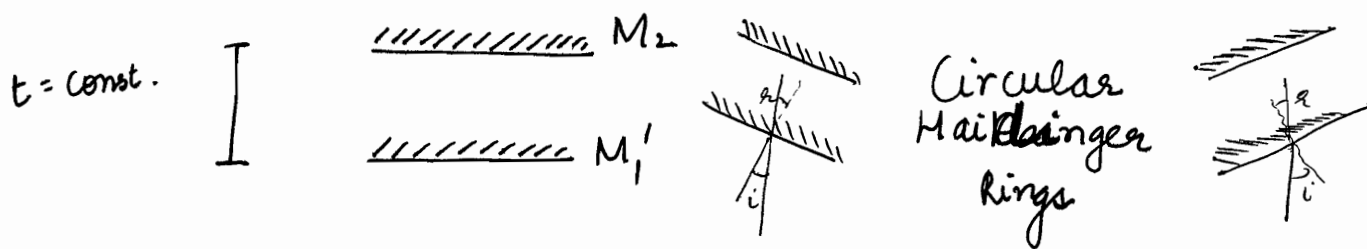

$$\Delta = 2\mu t - \frac{\lambda}{2} \quad (\text{for normal incidence})$$

$$\delta = 2\mu t \cos \theta - \frac{\lambda}{2} \quad (\text{for oblique incidence})$$

Note that  $r = i$  due to same dielectric

①  $2\mu t \cos r = n\lambda$

$\mu=1, r=0$

$2t = n\lambda$

Its like interference by the film in between  $M_2$  and  $M_1$ ,

$\Delta = 2\mu t \pm \frac{\lambda}{2} \Rightarrow$  Central spot dark among Haidinger's Rings

[last ~~dark~~ at semi-transparent slab]

② If  $M_1$  and  $M_2$  are  $\perp$ , only then ~~perpendicular~~ circular rings.

$\Rightarrow$  If  $t$  is fixed,  $\cos r$  will determine  $n$ .

③ If  $M_1$  and  $M_2$  are not  $\perp \Rightarrow$  wedge shaped film  $\Rightarrow$  straight fringes parallel to edge of the wedge.

[approximation of hyperbola]

$t$  is variable  $\Rightarrow$  fringes of const. width

Circular Rings when  $2t = n\lambda$

Move  $t$  by  $(\lambda/2) \Rightarrow 2t$  shifts by  $\lambda \Rightarrow$  next bright.

Move by distance  $x$ , count the shifts.

$2\Delta t = \Delta n\lambda$

$\Rightarrow 2x = N\lambda$  (1)

meter determined  $\Rightarrow$

$x = \left(\frac{N\lambda}{2}\right)$

$\Rightarrow$

$\lambda = \left(\frac{2x}{N}\right)$  (2)

$\lambda$  determined

① hence  $x$  is determined  $\Rightarrow$  meter standardized

② hence  $\lambda$  is determined !!

$N = \frac{2x}{\lambda}$

Now we put a small sheet of thickness  $l$

$\Rightarrow$  optical path moved =  $(\mu - 1)l$  in 1 direction

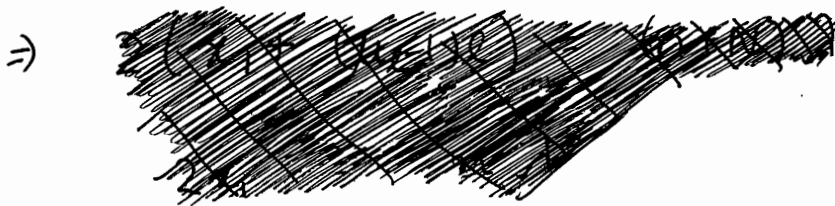

if  $N$  bright spot shifted on placing the sheet

$\Rightarrow$   $(\mu - 1)l = N \left( \frac{\lambda}{2} \right)$  (3)

$\mu$  determined

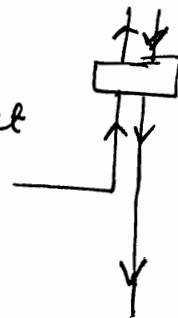

$\Rightarrow$  Extra Optical Path =  $2(\mu - 1)t$

$\Rightarrow 2(\mu - 1)t = N\lambda$   
for other bright pattern

To determine spectral width of light source:

This device does not have good resolving power.

eg. Sodium lamp :  $5890 \text{ \AA}$  &  $5896 \text{ \AA}$

It cannot form separate rings for  $\lambda_1$  and  $\lambda_2$

⊙ If Maxima of  $\lambda_1$  coincides with maxima of  $\lambda_2$   
 $\Rightarrow$  Fringes are distinct, visible

⊙ If Maxima of  $\lambda_1$  coincides with minima of  $\lambda_2$   
 $\Rightarrow$  Fringe pattern disappears

$t_1$ : width<sub>1</sub>  
 $t_2$ : width<sub>2</sub>  
 $t$ : width changed

$$2t_1 = n_1 \lambda_1 = n_2 \lambda_2$$

$$- 2t_2 = n_3 \lambda_1 = n_4 \lambda_2$$

$$\Rightarrow 2t = n \lambda_1 = (n+1) \lambda_2$$

Condition for appearance of fringes :

$$2t = n \lambda_1 = (n+1) \lambda_2 \quad \leftarrow \text{Visible}$$

Condition for disappearance of fringe pattern

$$2t' = n \lambda_1 = \left( n + \frac{1}{2} \right) \lambda_2 \quad \leftarrow \text{Invisible}$$



⊛ By any of these 2 methods, we can find spectral length  $[\lambda_2 - \lambda_1]$  .....

$$2t \left[ \frac{1}{\lambda_2} - \frac{1}{\lambda_1} \right] = \frac{1}{2}$$

$$2t \frac{\Delta\lambda}{\lambda_1 \lambda_2} = \frac{1}{2}$$

$$\Delta\lambda = \frac{\lambda_1 \lambda_2}{4t} \approx \frac{\lambda^2}{4t}$$

$$\Rightarrow \boxed{\Delta\lambda = \frac{\lambda^2}{4t}}$$

$t$  is the distance moved for disappearance after initial appearance

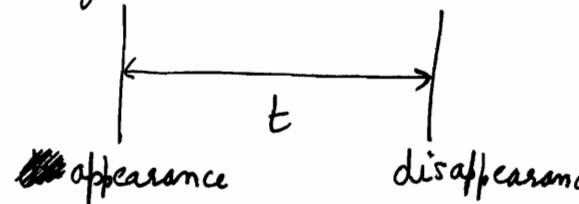

2 discrete wavelengths



$$\boxed{\text{Resolving power} = \left( \frac{\lambda}{\Delta\lambda} \right)}$$

$$\boxed{\text{Spectral Purity} = \frac{\lambda}{\Delta\lambda}}$$

$$\boxed{\text{Coherence length} = \frac{\lambda^2}{\Delta\lambda}}$$

$$2t = n\lambda_1 = (n+1)\lambda_2$$

$$\frac{2t}{\lambda_1} = n$$

$$\frac{2t}{\lambda_2} = n+1$$

$$\Rightarrow 2t \left[ \frac{1}{\lambda_1} - \frac{1}{\lambda_2} \right] = 1$$

$$\Rightarrow \boxed{\Delta\lambda = \frac{\lambda^2}{2t}}$$

$t$  is the distance moved for appearance again.

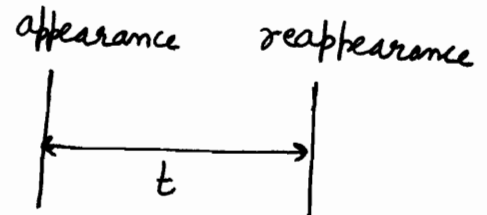

★ For a continuous spectra of michelson experiment, once interference pattern disappears, it won't reappear again

$$\Rightarrow \frac{2d}{\lambda} - \frac{2d}{\left(\lambda + \frac{\Delta\lambda}{2}\right)} \geq \frac{1}{2} \Rightarrow \text{again it will not appear}$$

$$\Rightarrow \frac{2d}{\lambda} - \frac{2d}{\lambda} \left[1 + \frac{\Delta\lambda}{2\lambda}\right]^{-1} \geq \frac{1}{2}$$

$$\Rightarrow \frac{2d}{\lambda} \cdot \frac{\Delta\lambda}{2\lambda} \geq \frac{1}{2}$$

$$\Rightarrow 2d \geq \left[\frac{\lambda^2}{\Delta\lambda}\right]$$

Can't be ignored  
Wavelengths Continuum

Spectral Purity 5

Basically in limiting case  
 $2d = n\lambda = \left(n + \frac{1}{2}\right) \left(\lambda + \frac{\Delta\lambda}{2}\right)$   
 $\Rightarrow \frac{2d}{\lambda} - \frac{2d}{\lambda + \frac{\Delta\lambda}{2}} \geq \frac{1}{2}$

★ In order to observe the Newton's rings, the microscope or the eye should be focussed on the upper surface of the film.

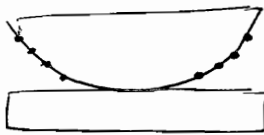

In Newton Rings, Diameter  $d \propto \sqrt{n} \Rightarrow$  spacing between second & third dark ring will be smaller than spacing between first and second dark ring.

★ For Michelson interferometer, remember that as we start reducing value of  $d$ , fringes will ~~start collapsing at~~ ~~become less closely packed~~ become less closely packed.  $\beta \propto \left(\frac{1}{d}\right)$

In Michelson Interferometer, central fringe is dark. i.e.  $\Delta = 2ut \cos \theta - \frac{\lambda}{2}$

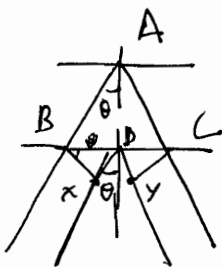
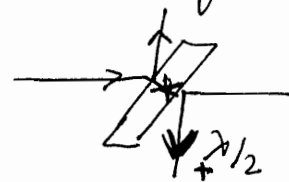

$$\Delta = 2AB - 2\lambda D$$

$$= \frac{2t}{\cos \theta} - \frac{2t}{\cos \theta} \sin^2 \theta = 2t \cos \theta$$

Also we have  $(\lambda/2)$  due to (shown as above) reason.

# OPTICS (10)

15/12/2011

## Fabry Perot Interferometer Multiple Beam Interference

this ray is not allowed

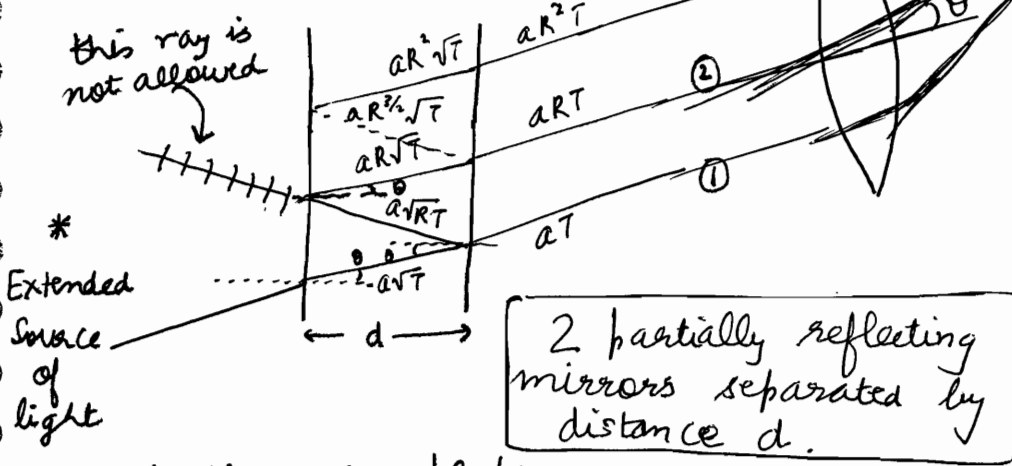

Haidinger rings!!

Interference of Transmitted light

• 2 similar glass plates

• d can be varied

let reflection coefficient = r &

$$r^2 = R \Rightarrow a_r = \sqrt{R} a_i$$

where  $R = \left(\frac{a_r}{a_i}\right)^2$

let transmission coefficient = t &

$$t^2 = T \Rightarrow a_t = \sqrt{T} a_i$$

where  $T = \left(\frac{a_t}{a_i}\right)^2$

Note that

• Hence we can see transmitted beams of amplitude  $a_i T, a_i R T, a_i R^2 T, \dots, a_i R^\infty T$  from a single ray of light.

$$\Delta_{(1)(2)} = 2\mu d \cos \theta$$

$$\Phi_{(1)(2)} = \frac{2\pi}{\lambda} \cdot \Delta_{(1)(2)}$$

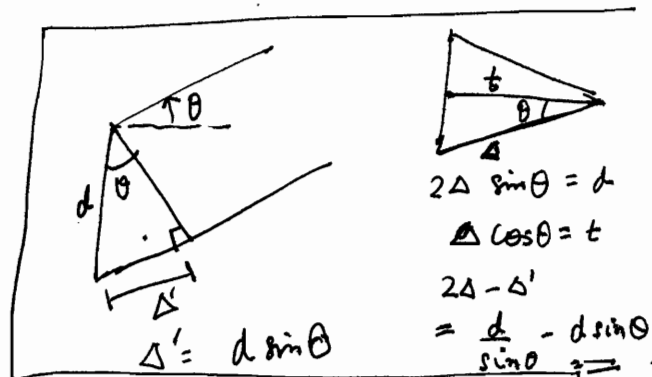

if ① :  $a_T e^{-i\omega t}$   
 $\Rightarrow$  ② :  $a_{RT} e^{-i(\omega t + \phi)}$

⊗ Till now we were discussing interference between two beams, derived either from division of wavefront or division of Amplitude. In Fabry Perot interference, we discuss interference of Many beams derived from a single beam by multiple reflections.

$$y_1 = aT e^{-i\omega t}$$

$$y_2 = aR T e^{-i(\omega t + \phi)}$$

$$y_3 = aR^2 T e^{-i(\omega t + 2\phi)}$$

$$y = y_1 + y_2 + y_3 + \dots$$

$$\Rightarrow y = aT e^{-i\omega t} [1 + R e^{-i\phi} + R^2 e^{-i2\phi} + \dots]$$

$$= aT e^{-i\omega t} \left[ \frac{1}{1 - R e^{-i\phi}} \right]$$

$$\begin{aligned} \text{Intensity} = y y^* &= \frac{a^2 T^2}{(1 - R e^{-i\phi})(1 - R e^{i\phi})} \\ &= \frac{a^2 T^2}{1 + R^2 - R[e^{-i\phi} + e^{i\phi}]} \\ &= \frac{a^2 T^2}{1 + R^2 - 2R \cos \phi} \\ &= \frac{a^2 T^2}{1 + R^2 - 2R \cos \phi - 2R + 2R} \\ &= \frac{a^2 T^2}{(1 - R)^2 + 2R(1 - \cos \phi)} \\ &= \frac{a^2 T^2}{(1 - R)^2 + 4R \sin^2\left(\frac{\phi}{2}\right)} \\ &= \frac{a^2 T^2}{(1 - R)^2 \left[ 1 + \frac{4R}{(1 - R)^2} \sin^2\left(\frac{\phi}{2}\right) \right]} \end{aligned}$$

★ Fringes formed in Multi-beam spectroscopy are much sharper than those of 2-beam interference.  $\therefore$  Fabry Perot Interferometer has high resolving power and used in high resolution spectroscopy.

$$I_{\max} \text{ for } \sin^2\left(\frac{\phi}{2}\right) = 0$$

$$I_0 \text{ or } I_{\max} = \frac{a^2 I^2}{(1-R)^2}$$

$$\Rightarrow \left(\frac{\phi}{2}\right) = \pm n\pi$$

$$\Rightarrow \boxed{\phi = \pm 2n\pi}$$

$$\phi = \frac{2\pi}{\lambda} \cdot \Delta = \pm 2n\pi$$

$$\Rightarrow \boxed{\Delta = n\lambda}$$

MAXIMAS...

$$\Rightarrow \boxed{\cos \theta = \frac{n\lambda}{2\mu d}}$$

$$2\mu d \cos \theta = n\lambda$$

For air  $\mu=1$   
 $\theta = 0^\circ$

$$\Rightarrow \boxed{2d = n\lambda}$$

$$\checkmark \frac{4R}{(1-R)^2} : \text{Coefficient of fineness} : F$$

More F, more will be the sharpness of fringes, more will be resolving power

$$\Rightarrow \boxed{I = \frac{I_0}{1 + F \sin^2\left(\frac{\phi}{2}\right)}$$

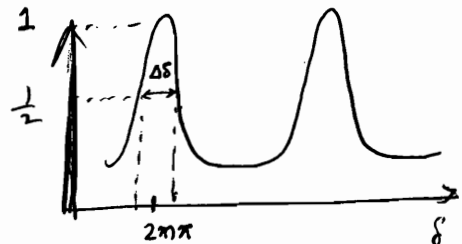

$$I = \frac{1}{2} \text{ for } \delta = 2m\pi \pm \delta_s$$

$$\delta (= \phi) F \sin^2\left(\frac{\Delta\delta}{4}\right) = \frac{1}{2}$$

$$\Delta\delta = \frac{\sqrt{16}}{\sqrt{F}}$$

$$\text{If } R = 0.9 \Rightarrow F = \frac{4 \cdot 0.9}{(0.1)^2} = \frac{0.36 \times 100}{0.01} = 360$$

= Full width at Half Maximum

$$\text{If } \boxed{I = \frac{I_0}{2}} \Rightarrow \frac{1}{2} = \frac{1}{1 + F \sin^2\left(\frac{\phi}{2}\right)} \Rightarrow \sin^2\left(\frac{\phi}{2}\right) = \frac{1}{F} = \frac{(1-R)}{4R}$$

$$\Rightarrow \frac{\phi}{2} = \frac{1-R}{2\sqrt{R}} \Rightarrow \boxed{\phi = \frac{1-R}{\sqrt{R}}} : \text{Half Frequency Angle.}$$

→ This device has high resolving power i.e. separate rings for different wavelengths.

When  $d$  is moved by  $\lambda/2$

⇒  $2d$  moves by  $\lambda$

i.e. if  $x = \left[ \frac{N\lambda}{2} \right]$

and  $2d = n\lambda$

⇒  $2d' = (N+n)\lambda$

⇒  $2x = N\lambda$

⇒  $x = \left( \frac{N\lambda}{2} \right)$

⇒  $\lambda = \left( \frac{2x}{N} \right)$  if  $x$  known

$x = \left( \frac{N\lambda}{2} \right)$  if  $\lambda$  known

Everything same as  
Michelsons Interferometer.....

$\lambda$  determined

'm' standardized

To determine  $\mu$

Similarly,

$2(\mu-1)d = N\lambda$  [  $N$  fringes shifted ]

⇒  $\mu = \left( 1 + \frac{N\lambda}{2d} \right)$

To determine Spectral Width

Similarly,

~~$2d' = n_1 \lambda_1 = n_2 \lambda_2$~~  : appearance  
 ~~$2d' = n_1 \lambda_1 = \left( n_2 + \frac{1}{2} \right) \lambda_2$~~  : disappearance

$$2d_1'' \left( \frac{1}{\lambda_1} - \frac{1}{\lambda_2} \right) = \frac{1}{2}$$

$$\Rightarrow \lambda_1 - \lambda_2 = \frac{\lambda^2}{4d_1''}$$

$$2d'' = n_1 \lambda_1 = (n_2 + 1) \lambda_2$$

~~reappearance~~

$$2d_1' = n_1 \lambda_1 = \left( n_2 + \frac{1}{2} \right) \lambda_2$$

$$2d_2' = n_2 \lambda_1 = \left( n_2 + \frac{1}{2} \right) \lambda_2$$

$$\Rightarrow \frac{2d_1'}{\lambda_1} - \frac{2d_2'}{\lambda_2} = \frac{1}{2}$$

$$\Rightarrow d_1'' =$$

→ Fabry Perot has high resolving power as compared to Michelson Interferometer

As done in Michelson Interferometer

$$\Delta \lambda = \frac{\lambda^2}{4d_1}$$

or

$$\Delta \lambda = \frac{\lambda^2}{2d_2}$$

appearance  $d_1$  disappearance

$d_1$ : width moved by  $d_1$

appearance  $d_2$  appearance

$d_2$ : width moved by  $d_2$

# Modes (Polychromatic source) similar to modes of laser

For maxima,  $\lambda = \frac{2d}{n}$

$$2d = m\lambda_m \Rightarrow \lambda_m = \frac{2d}{m}$$

$$\Rightarrow \nu_m = \left(\frac{c}{2d}\right)^m$$

$$\nu_{min} = \frac{c}{\lambda_{max}} = \frac{nc}{2d}$$

$$\Rightarrow \Delta\nu_m = \left(\frac{c}{2d}\right)$$

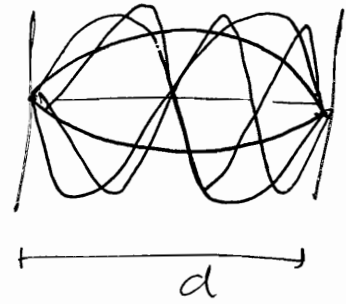

Longitudinal Modes defined as :-

$$\nu_0, \nu_0 \pm \Delta\nu, \nu_0 \pm 2\Delta\nu$$

it can be 1 or 3 or 5 or 7 depending upon spectral width available.

$$\Delta\nu = \frac{(n+\Delta n)c}{2d} - \frac{nc}{2d} = \Delta n \left(\frac{c}{2d}\right)$$

$$\Delta\nu < W$$

$\Rightarrow \left(\frac{c}{2d}\right)$  से separated सारी frequencies के लिए, particular d, पर, interference maxima मिलेंगी !!

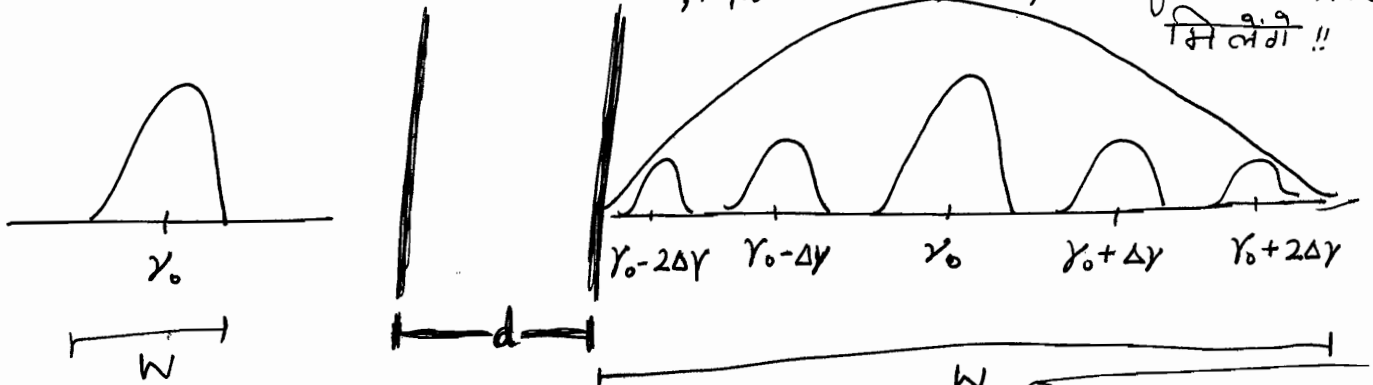

$W$ : Spectral Width

For a given spectrum and given d, we have 4 freq. around central frequency for which intensity resonance is there

$$\nu = \frac{c}{\lambda}$$

$$d\nu = -\frac{c}{\lambda^2} d\lambda$$

$$\Rightarrow |\Delta\nu| = \frac{c}{\lambda^2} |\Delta\lambda|$$

$$\Rightarrow \left(\frac{d\nu}{\nu}\right) = -\left(\frac{d\lambda}{\lambda}\right)$$

21  $\nu_0 \pm \Delta\nu n \Rightarrow \text{shift} = \text{spectral width} = 2n \Delta\nu$

$$\Delta\nu = \frac{c}{2d} \Rightarrow \underline{SW} = \frac{2nc}{2d} = \left(\frac{nc}{d}\right)$$

$$\Rightarrow n = \frac{(SW) \times d}{c}$$



In Michelson Interferometer, condition of disappearance of rings :-

$$2d = n\lambda_1 = \left(n + \frac{1}{2}\right) \lambda_2$$

$$\frac{2d}{\lambda_2} = n + \frac{1}{2} \quad \frac{2d}{\lambda_1} = n$$

$$\Rightarrow 2d \frac{\lambda_1 - \lambda_2}{\lambda_1 \lambda_2} = \frac{1}{2}$$

$$\Rightarrow \boxed{\Delta\lambda = \frac{\lambda^2}{4d}}$$

We assumed 2 wavelengths, let us say continuous spectra

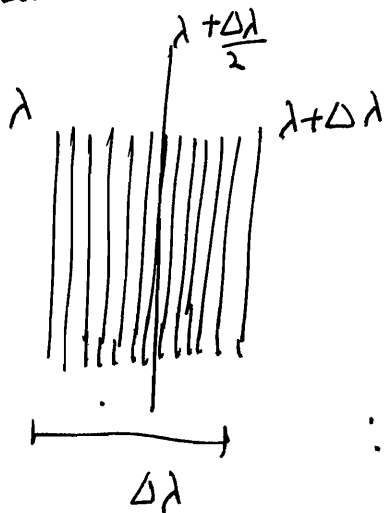

Now

$$\boxed{\Delta\lambda = \frac{\lambda^2}{2d}}$$

$$\therefore 2d = n\lambda = \left(n + \frac{1}{2}\right) \left(\lambda + \frac{\Delta\lambda}{2}\right)$$

Pattern appears when conditions of interference are met i.e. coherent sources.

## 2 Criteria for Coherence:

TEMPORAL COHERENCE  
Coherence wrt. time



definite phase relationship  
wrt. time

"Coherent Time" is a characteristic  
of light source :-

[Time Period for which light source  
oscillations are perfectly sinusoidal]

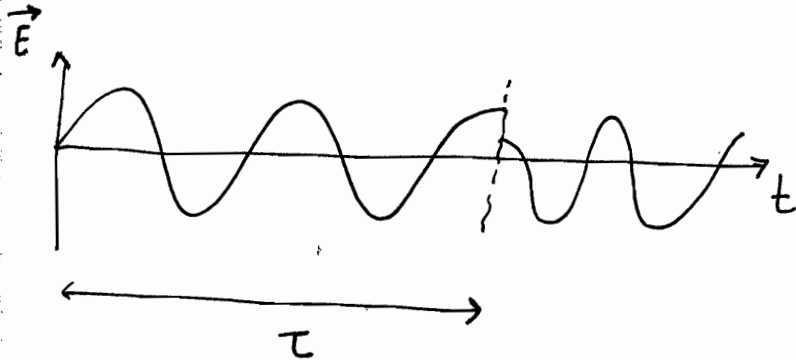

→ Standard light source have  $\tau$   
 $= 10^{-10}$  to  $10^{-8}$  seconds.

SPATIAL COHERENCE  
Coherence wrt. space



"Coherent length"

$$L = \tau * c$$

2 Points in space maintain  
const. phase relationship  
as long as the distance  
between them is less than  
coherent length

$$\text{ie. } d < L$$

Hence if criteria for coherence is not ~~specific~~ met,  
this implies interference will not take place  
⇒ pattern will disappear.

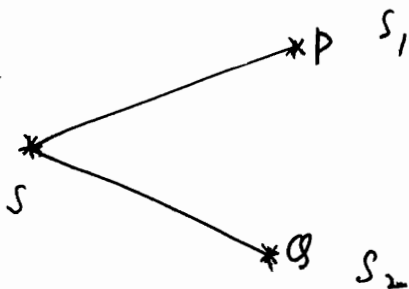

$$SP - SQ \leq L$$

In Michelson Interferometer, Pattern disappears

when  $2d = \left(\frac{\lambda^2}{\Delta\lambda}\right)$

→ We are "2d" as coherent length as that is the length that the wave has to travel extra. अगर इतने लम्बा में Phase shift हो गया, then coherence will break

We can take Coherent length as  $\left(\frac{\lambda^2}{\Delta\lambda}\right)$

i.e.  $l = \frac{\lambda^2}{\Delta\lambda}$

General definition of coherence length

$\left[\frac{\lambda^2}{\Delta\lambda}\right]$  is called  $\mathcal{Q}$

Purity of spectral line

when  $\Delta\lambda \rightarrow 0$ , Purity will becomes  $\infty$  i.e. fully pure

$l = \lambda \mathcal{Q}$

(\*) In the visible region of spectrum, silver is the best metal to coat. (reflectivity  $\approx 95\%$ )

(\*) Longitudinal Modes For polychromatic beam, incident normally on Fabry Perot etalon, with air ( $\mu=1$ )

For an incident beam having  $\nu = 6 \times 10^{14}$  Hz and spectral width of 7000 MHz. For  $d = 10$  cm,

$\therefore \lambda = \frac{2d}{n}$  &  $\left(\frac{c}{2d}\right) = 1500$  MHz

$\nu = \frac{nc}{2d}$

$\Rightarrow \Delta\nu = \left(\frac{c}{2d}\right)$

$\Rightarrow \Delta\nu = 1500$  MHz

$2\Delta\nu = 3000$  MHz

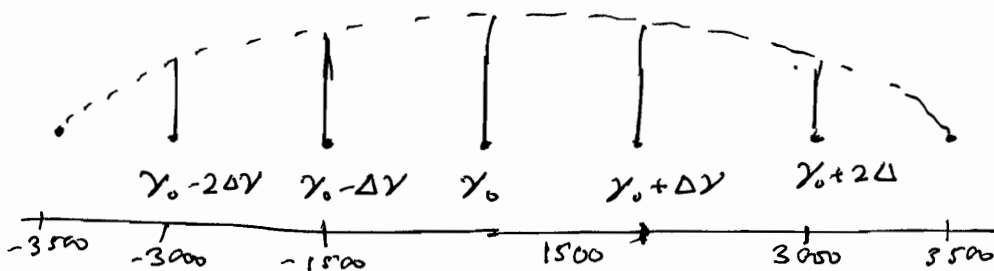

✓ (★) Fabry Perot Interferometer can resolve wavelengths differing by about  $10^{-3} \text{ \AA}$ . This is in contrast to that of a grating  $\approx 10^{-1} \text{ \AA}$  and that of prism  $\approx 1 \text{ \AA}$  @  $5000 \text{ \AA}$ .

✓ (★) If a plane wave is incident on an aperture, then according to geometrical optics, a sharp shadow will be cast

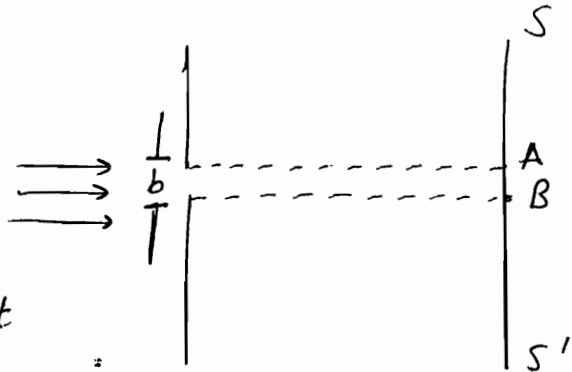

Around the region AB of the screen, and AB will be illuminated with sharp boundaries. However if width of slit is comparable to wavelength, then the intensity pattern varies and there is some intensity in the geometrical shadow. If the width of the slit is made smaller, larger amount of energy reaches the geometrical shadow. This spreading out of wave when it passes through a narrow opening is referred to as diffraction.

### (★) Graph of Fabry Perot

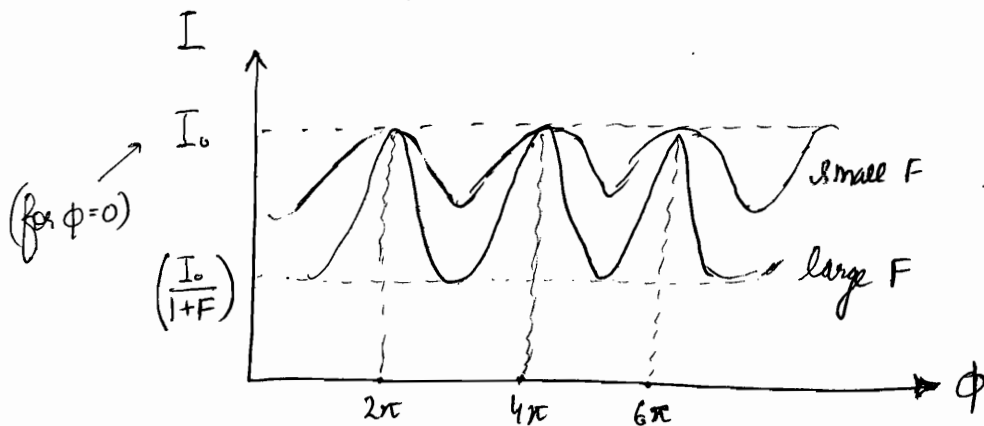

— high  $R \Rightarrow$  high fineness  
 — lower  $R \Rightarrow$  lower fineness

$$I = \frac{I_0}{1 + F \sin^2\left(\frac{\phi}{2}\right)}$$

$$F = \frac{4R}{(1-R)^2} \quad \begin{array}{l} \text{if } R \uparrow \approx 0.9 \Rightarrow F \upuparrow \\ \quad \quad \quad \Rightarrow I_{\text{dark}} \downarrow \\ \quad \quad \quad \Rightarrow \text{fine or sharp} \\ \text{if } R \downarrow \approx 0.1 \Rightarrow F \downarrow \Rightarrow I_{\text{dark}} \upuparrow \\ \quad \quad \quad \Rightarrow \text{not fine} \end{array}$$

# OPTICS (II)

16/12/2011

## DIFFRACTION

1765, diffraction discovered by

Grimaldi

Whenever 2 waves (monochromatic) simultaneously disturb a media, certain points shows maximum intensity while some show ~~some~~ minimum intensity.

The intensity of maxima keeps on decreasing & distance b/w maxima keeps on decreasing.

This is called Diffraction

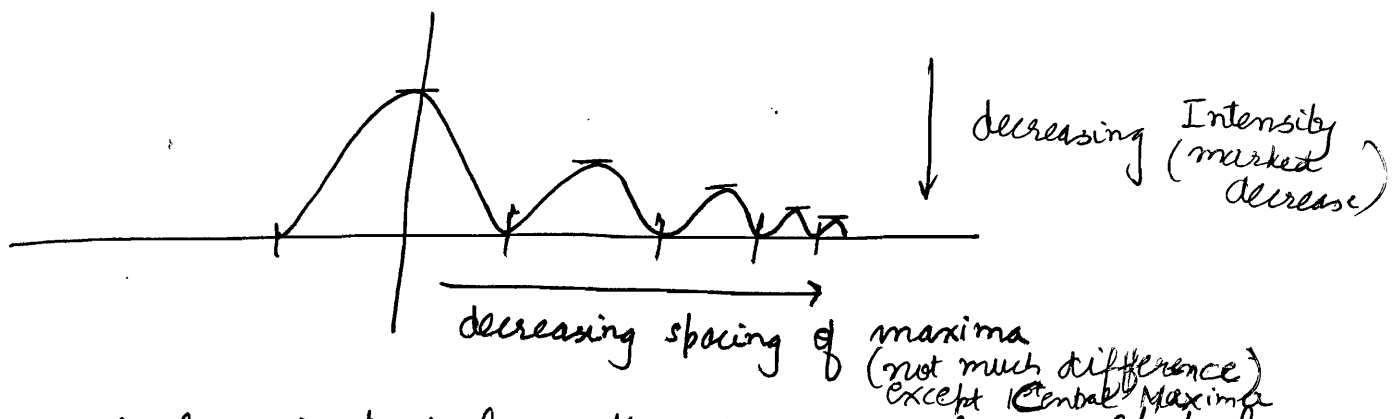

Beam of light is bent from the corners of an obstacle.

(Obstacle should be OPAQUE or non-transparent)

When it is brought into focus, diffraction pattern is observed.

I ↓ and (distance) ↓ are the 2 major differences in Interference & Diffraction

3<sup>rd</sup> major difference is Interference is superposition of secondary wavelets from point sources. while diffraction is superposition of waves coming out of an area like circular aperture.

→ For diffraction to occur, length of obstacle should be comparable to  $\lambda$  wave.

length of obstacle should be

→ जितना ज्यादा  $\lambda$ , उतने ज्यादा diffraction effects. eg.

1) sound : high diffraction

2) geometrical optics :  $\lambda$  assumed 0 for ignoring diffraction effects

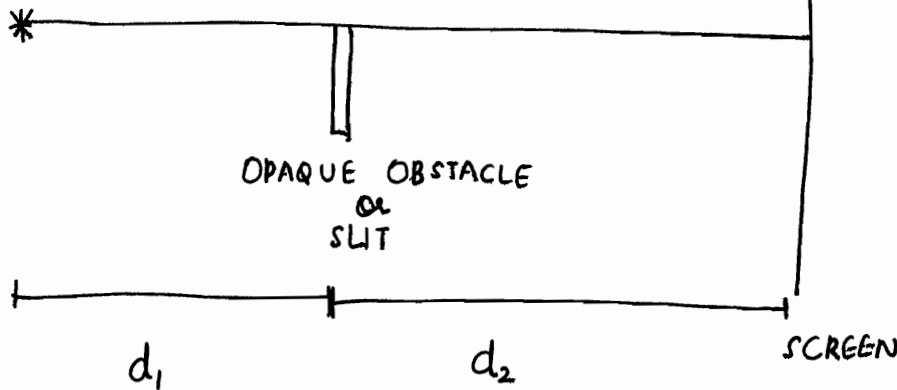

If  $d_1$  and  $d_2$  are finite  $\Rightarrow$  Fresnel diffraction

If either is infinite  $\Rightarrow$  Fraunhofer diffraction

### Fresnel Diffraction

- 1) distances are finite
- 2)  $\Rightarrow$  any kind of wavefront can be used  
Spherical or cylindrical or plane
- 3)  $\Rightarrow$  No lenses are required
- 4) In fresnel pattern, the pattern is the shadow of diffracting obstacle or aperture modified by diffraction.

### Fraunhofer Diffraction

- 1) distances are  $\infty$
- 2)  $\Rightarrow$  only plane wavefront can be used.
- 3)  $\Rightarrow$  Converging lens are reqd. to observe the patterns
- 4) In fraunhofer, pattern is image of source modified by diffraction and thereby needs diffraction screen to be placed in conjugate plane of object

# FRAUNHOFER DIFFRACTION

- ⊙ Single slit Diffraction
- ⊙ Double slit Diffraction
- ⊙ N-slit diffraction
- ⊙ Resolving Power
- ⊙ Circular Aperture

Diffraction Pattern due to single slit

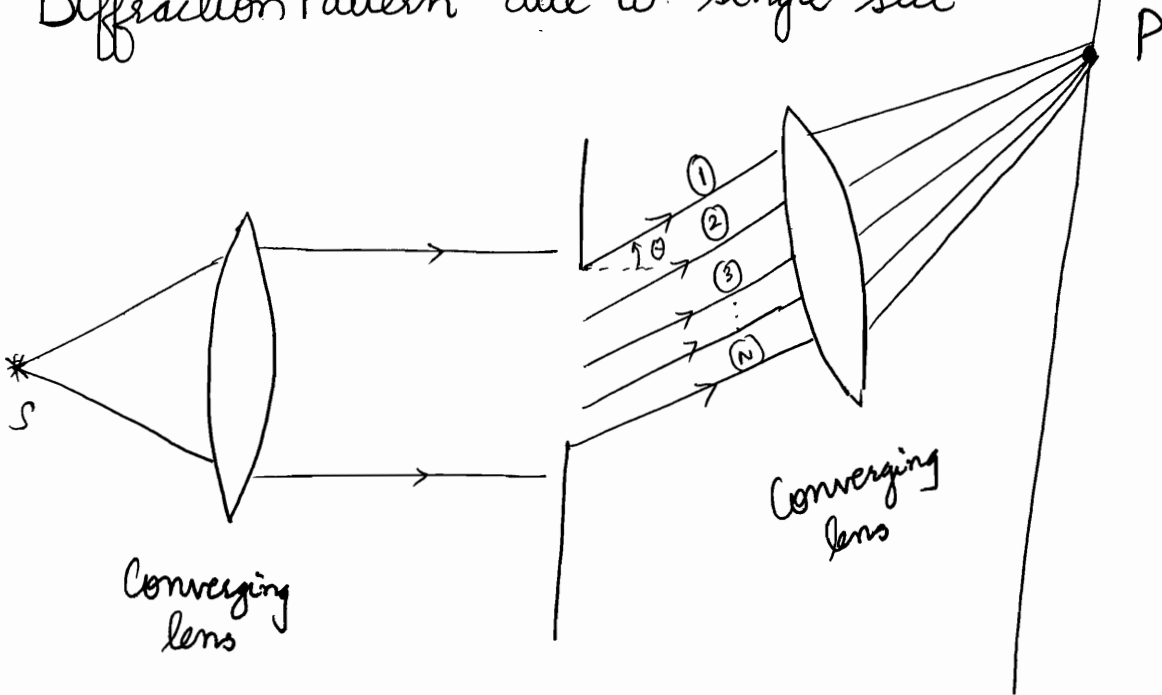

$\theta$ : angle of diffraction

Standard case is normal incidence.

Wavefront is divided into  $N$  wavelets

distance between wavelets =  $(d/N)$

Amplitude of wave =  $A = Na$

Amplitude of wavelet =  $(A/n) = a$  (say)

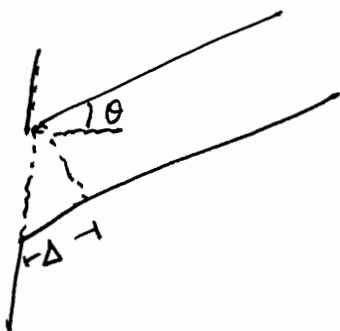
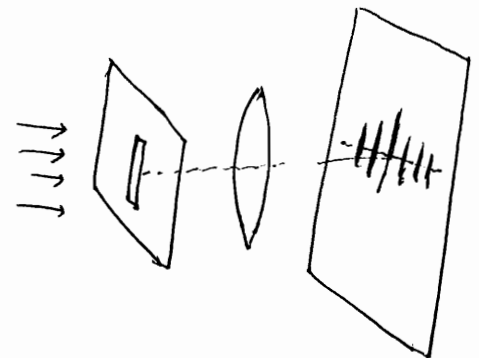

$\Delta$  b/w any 2 successive wavelets

$$= \frac{d}{N} \sin \theta$$

$$\Rightarrow \Delta \phi = \frac{2\pi}{\lambda} \left( \frac{d}{N} \right) \sin \theta$$

$$y_1 = a e^{-i\omega t}$$

$$y_2 = a e^{-i(\omega t + \phi)}$$

$$y_3 = a e^{-i(\omega t + 2\phi)}$$

$$y_N = a e^{-i(\omega t + (N-1)\phi)}$$

$$y = y_1 + y_2 + \dots + y_N$$

$$= a e^{-i\omega t} [1 + e^{-i\phi} + e^{-i2\phi} + \dots + e^{-i(N-1)\phi}]$$

$$= a e^{-i\omega t} \left[ \frac{1 \cdot (1 - e^{-i\phi N})}{(1 - e^{-i\phi})} \right]$$

$$= a e^{-i\omega t} \begin{matrix} e^{-iN\frac{\phi}{2}} \\ e^{-i\frac{\phi}{2}} \end{matrix} \left[ \frac{e^{iN\frac{\phi}{2}} - e^{-iN\frac{\phi}{2}}}{e^{i\frac{\phi}{2}} - e^{-i\frac{\phi}{2}}} \right]$$

$$= a e^{-i\omega t} e^{-i(N-1)\frac{\phi}{2}} \frac{\sin\left(\frac{N\phi}{2}\right)}{\sin\left(\frac{\phi}{2}\right)}$$

$$y = \left[ \frac{a \sin\left(\frac{N\phi}{2}\right)}{\sin\left(\frac{\phi}{2}\right)} \right] e^{-i\left[\omega t + (N-1)\frac{\phi}{2}\right]}$$

w/o loss of continuity

$$I = yy^*$$

$$I \propto R^2$$

$$I = k \frac{\sin^2\left(\frac{N\phi}{2}\right)}{\sin^2\left(\frac{\phi}{2}\right)}$$

$$\text{let } \frac{N\phi}{2} = \alpha$$

$$\Rightarrow \frac{\phi}{2} = \left(\frac{\alpha}{N}\right)$$

$$= k a^2 \left[ \frac{\sin\left(\frac{N\phi}{2}\right)}{\sin\left(\frac{\phi}{2}\right)} \right]^2 = k a^2 \left[ \frac{\sin \alpha}{\sin\left(\frac{\alpha}{N}\right)} \right]^2 \approx k a^2 \left[ \frac{\sin \alpha}{\left(\frac{\alpha}{N}\right)} \right]^2$$



$$R = \frac{a \sin\left(\frac{N\phi}{2}\right)}{\sin\left(\frac{\phi}{2}\right)}$$

$$R = Na \frac{\sin \alpha}{\alpha}$$

$$R = A \frac{\sin \alpha}{\alpha}$$

$$A = Na$$

$$\alpha = \frac{N\phi}{2} = N \frac{\pi}{\lambda} \cdot d \sin \theta$$

$$\alpha = \frac{\pi d \sin \theta}{\lambda}$$

$$I \propto R^2$$

$$I = k A^2 \frac{\sin^2 \alpha}{\alpha^2}$$

Central Maxima :  $\theta = 0 \Rightarrow \alpha = 0$

$$\Rightarrow I_{\text{Max}} = kA^2 \left[ \lim_{\alpha \rightarrow 0} \frac{\sin \alpha}{\alpha} \right]^2 = kA^2$$

$$\Rightarrow I = I_0 \frac{\sin^2 \alpha}{\alpha^2}$$

Minima

$I_{\text{min}}$  when  $\sin^2 \alpha = 0$  i.e.  $\alpha = \pm n\pi$   $n = 1, 2, 3, \dots$

All minima are perfectly dark....

$$\alpha = \frac{\pi d \sin \theta}{\lambda} = \pm n\pi \Rightarrow$$

$$d \sin \theta = \pm n\lambda$$

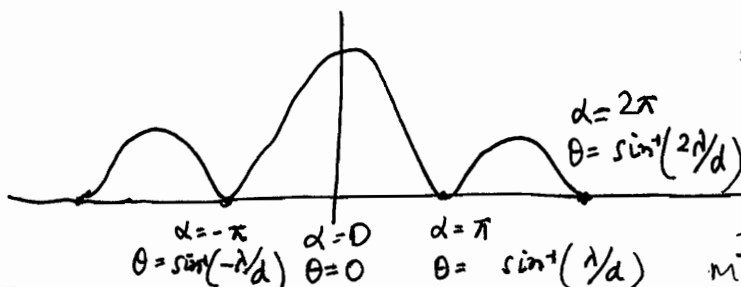

Note that if  $d < \lambda$   
 $\Rightarrow$  NO diffraction pattern  
 & slit acts as point  
 source with complete  
 illumination of screen.

It may be also seen as the  
 Maximum Possible Diffraction.

• Angular spread of Central Maxima

$$= 2 \sin^{-1} \left( \frac{\lambda}{d} \right)$$

• Half Angular spread of Central Maxima =  $\sin^{-1} \left( \frac{\lambda}{d} \right)$

(Note that angular spread of Central Maxima is around twice of that of other maxima)



• Angular spread of 1<sup>st</sup> maxima =  $\sin^{-1} \left( \frac{2\lambda}{d} \right) - \sin^{-1} \left( \frac{\lambda}{d} \right)$

## Maxima

To find out maxima,

$$\frac{d}{d\alpha} \left( \frac{\sin^2 \alpha}{\alpha^2} \right) = 0$$

$$\Rightarrow 2 \sin \alpha \cos \alpha \alpha^2 - 2\alpha \sin^2 \alpha = 0$$

$$\Rightarrow 2\alpha \sin \alpha [\alpha \cos \alpha - \sin \alpha] = 0$$

$$\Rightarrow \text{either } \frac{\alpha \sin \alpha = 0}{\text{or}} \quad \leftarrow \text{minima}$$

$$\boxed{\alpha = \tan \alpha} \quad \leftarrow \text{maxima}$$



transcendental equation : to be solved by graphical methods.

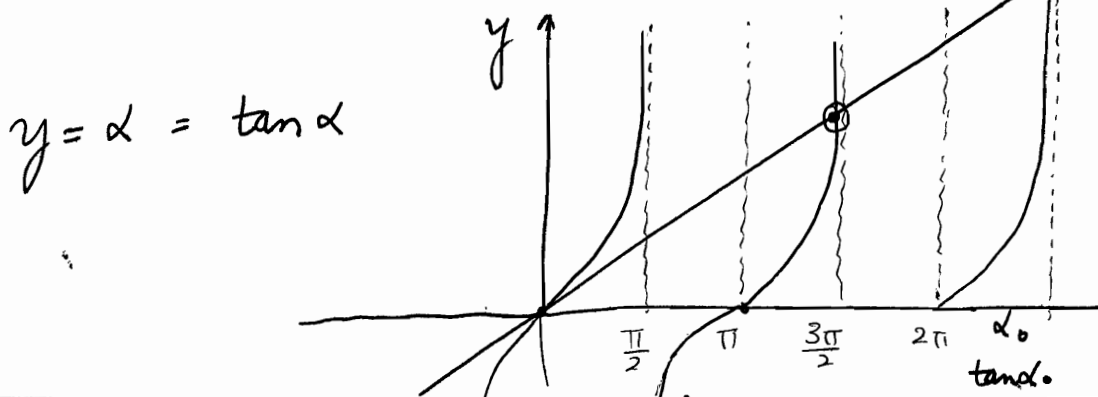

$$d : 1.46\pi, 2.43\pi, \leftarrow \text{Reducing spread of maximas...}$$

$$\approx \frac{3\pi}{2} \quad \approx \frac{5\pi}{2}$$

$$I_1 \approx I_0 \frac{\sin^2\left(\frac{3\pi}{2}\right)}{\left(\frac{3\pi}{2}\right)^2} \approx \boxed{\frac{I_0}{20}}$$

$$I_2 = \frac{I_0 \sin^2\left(\frac{5\pi}{2}\right)}{\left(\frac{5\pi}{2}\right)^2} = \boxed{\frac{I_0}{60}}$$

$$I_3 = \frac{I_0 \sin^2\left(\frac{7\pi}{2}\right)}{\left(\frac{7\pi}{2}\right)^2} = \boxed{\frac{I_0}{120}}$$

values  
verified  
from  
Ghatak

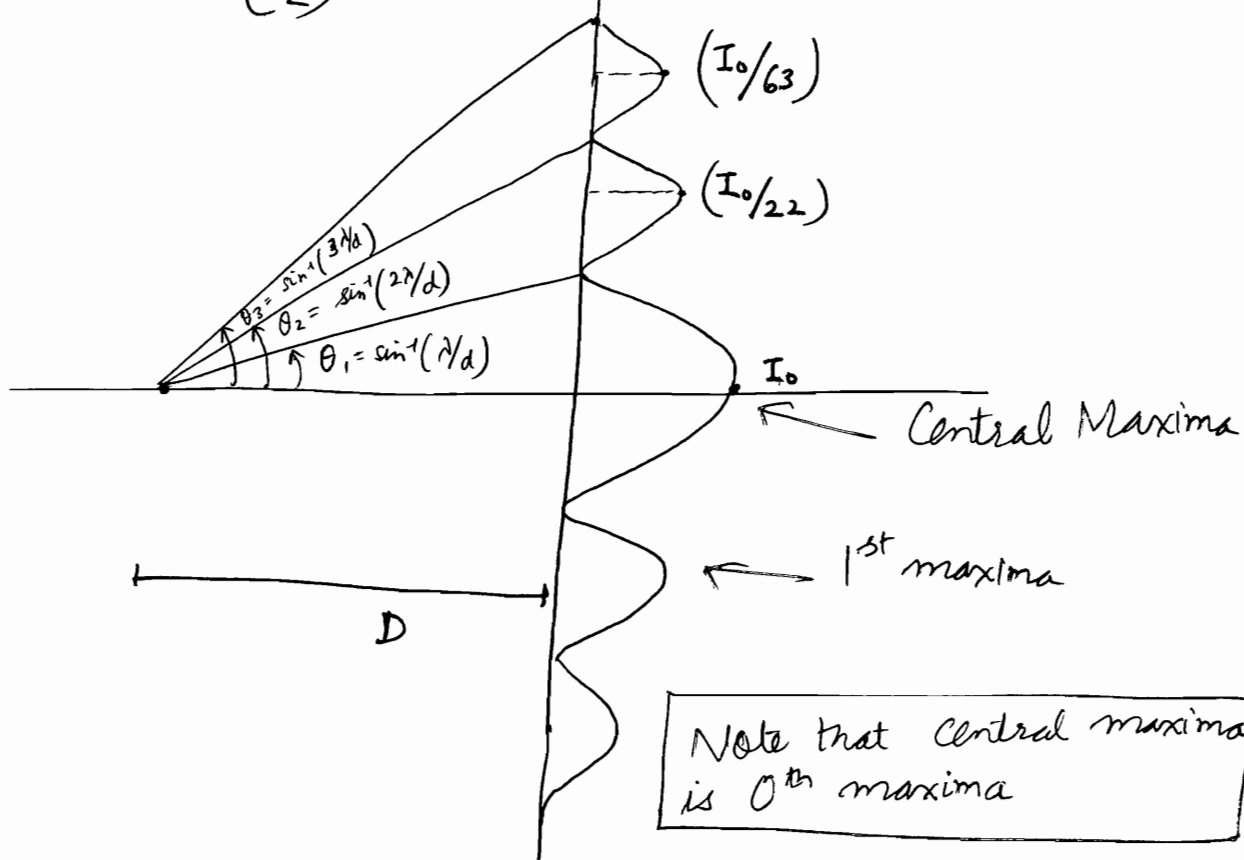

Note that central maxima is 0<sup>th</sup> maxima

# Linear Width of Central Maxima

Half linear spread  $\theta = \left( \frac{y_1}{D} \right) = \sin^{-1} \left( \frac{\lambda}{d} \right) \approx \left( \frac{\lambda}{d} \right)$

$$y_1 = \left( \frac{D \lambda}{d} \right)$$

# Linear Width of 1<sup>st</sup> Maxima

$$\alpha = \frac{3\lambda}{2} \Rightarrow \theta = \sin^{-1} \left( \frac{3\lambda}{2d} \right) \Rightarrow \frac{y_2}{D} = \sin^{-1} \left( \frac{3\lambda}{2d} \right) \approx \frac{3\lambda}{2d}$$

[ Minima are uniformly spaced  
while  
Maximas are not uniformly spaced ]

# Double Slit Diffraction

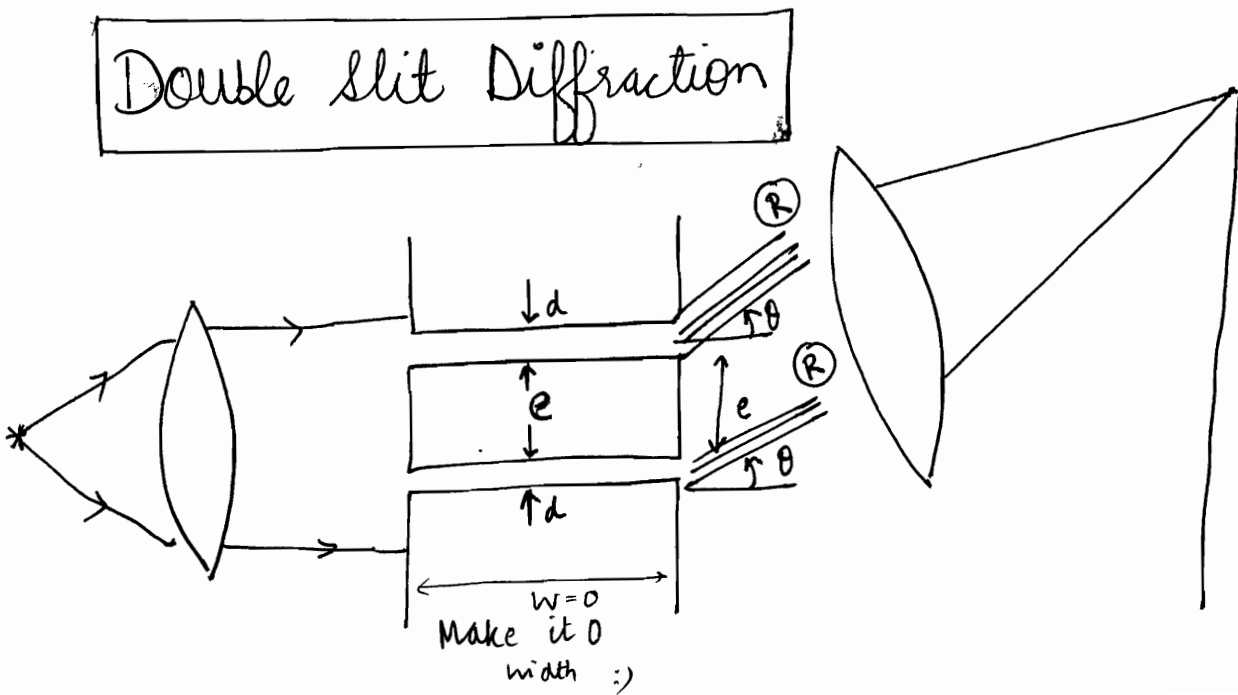

→ Centre to Centre spacing =  $(e+d)$

$$y_1 = R e^{-i(\omega t + \delta)}$$

$$y_2 = R e^{-i(\omega t + \delta + \frac{2\pi\Delta}{\lambda})}$$

$$\Delta = \frac{(e+d) \sin\theta}{\sin\theta}$$

$$\psi = \frac{2\pi}{\lambda} \Delta$$

$$R = A \left( \frac{\sin\alpha}{\alpha} \right)$$

$\{ y = y_1 + y_2 \}$  interference of 2 diffraction patterns

This is addition of 2 SHM

$$R'^2 = R^2 + R^2 + 2R^2 \cos\psi$$

$$= 4R^2 \cos^2\left(\frac{\psi}{2}\right)$$

$$I_p = R'^2 = 4R^2 \cos^2\left(\frac{\psi}{2}\right)$$

$$I_p = \underbrace{4A^2}_{I_0} \underbrace{\frac{\sin^2\alpha}{\alpha^2}}_{\text{diffraction term}} \underbrace{\cos^2\beta}_{\text{interference term}}$$

$$\alpha = \frac{\pi}{\lambda} d \sin\theta$$

$$\psi = \frac{2\pi}{\lambda} (e+d) \sin\theta$$

$$\beta = \frac{\psi}{2} = \frac{\pi}{\lambda} (e+d) \sin\theta$$

→ Its also called diffraction interference.

Central Maxima at  $\theta=0$

$$I_0 = 4A^2$$

Pattern will come via Multiplication of

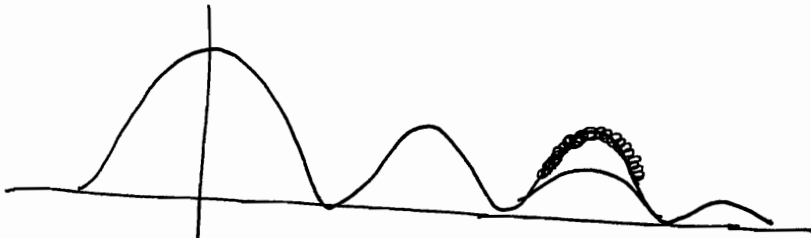

$$\left( \frac{\sin^2 \alpha}{\alpha^2} \right)$$

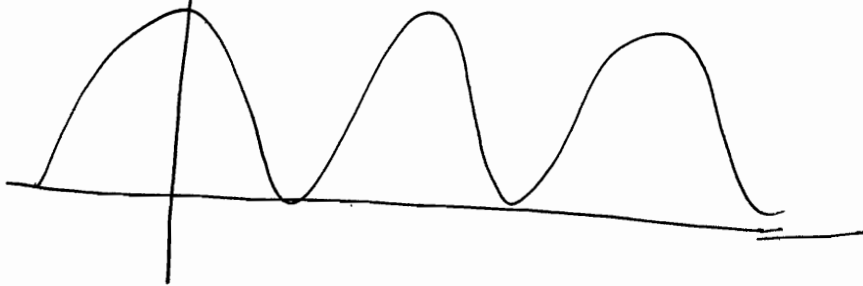

$$\cos^2 \beta$$

- ⊙  $\alpha : \frac{\pi d \sin \theta}{\lambda}$
- ⊙  $\beta : \frac{\pi (e+d) \sin \theta}{\lambda}$
- ⊙  $\sin \alpha :$
- ⊙  $\sin \beta :$

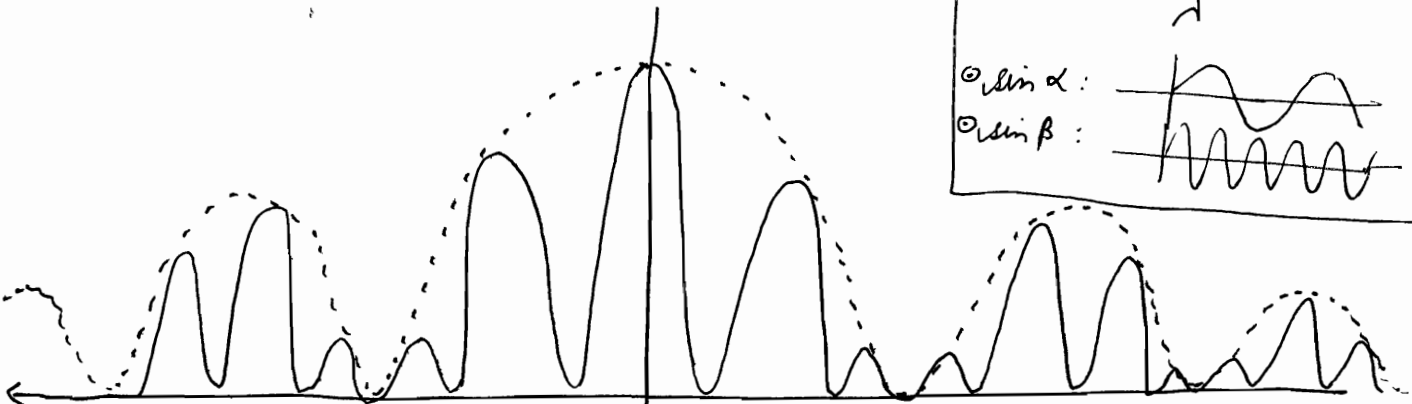

Central

→ No. of maxima within <sup>Central</sup> diffraction Maxima will depend upon  $(e+d/d)$  ratio.

# OPTICS (12)

17/12/2011

$$I_p = 4A^2 \frac{\sin^2 \alpha}{\alpha^2} \cos^2 \beta$$

Diffraction Minima

$$\alpha = n\pi \Rightarrow \frac{\pi}{\lambda} d \sin \theta = \pm n\pi \Rightarrow \boxed{d \sin \theta = \pm n\lambda}$$

$$n = \pm 1, \pm 2, \dots$$

Interference Maxima

$$\cos^2 \beta = 1$$

$$\beta = m\pi$$

$$\frac{\pi}{\lambda} (e+d) \sin \theta = \pm m\pi$$

$$\Rightarrow \boxed{(e+d) \sin \theta = \pm m\lambda}$$

$$m = \pm 0, \pm 1, \pm 2, \dots$$

How many interference maxima within central diffraction maxima

Condition of Missing Order

If  $n^{\text{th}}$  diffraction minima occurs at ~~at~~  $\theta_n$

$$\Rightarrow d \sin \theta_n = n\lambda$$

If  $m^{\text{th}}$  interference maxima occurs at  $\theta_m$

$$\Rightarrow (e+d) \sin \theta_m = m\lambda$$

If they coincide,  $m^{\text{th}}$  interference maxima will be missed.

i.e.  $\theta_n = \theta_m \Rightarrow m^{\text{th}}$  maxima is missing

$$\Rightarrow \frac{n\lambda}{d} = \frac{m\lambda}{(e+d)}$$

$$\text{i.e. } \boxed{\frac{e+d}{d} = \left(\frac{m}{n}\right)}$$

$m = 0, 1, 2, \dots$   
 $n = 1, 2, 3, \dots$

Q4)

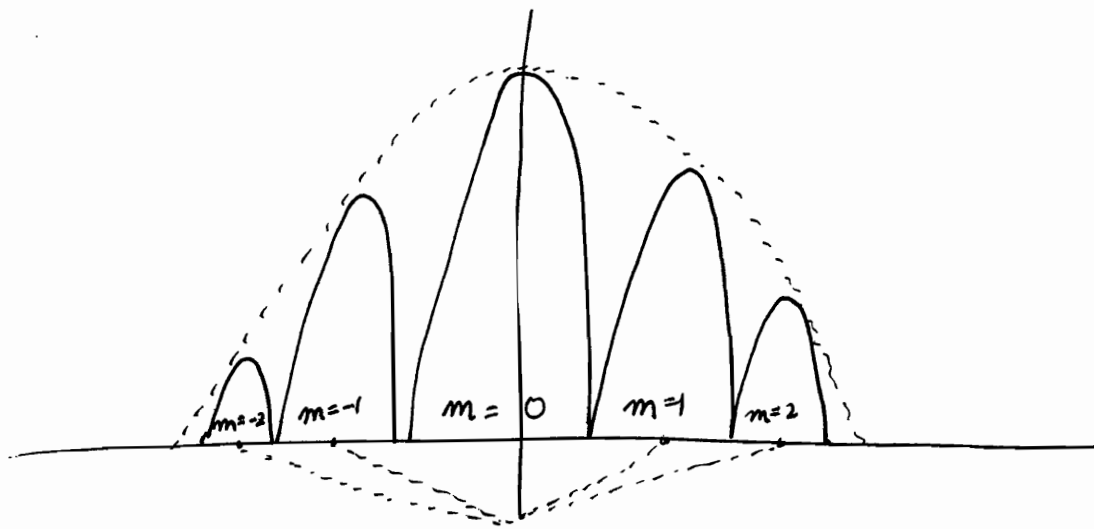

$$d = 2\lambda \quad e + d = 6\lambda \quad \frac{e+d}{d} = \left(\frac{3}{1}\right) = \left(\frac{m}{n}\right)$$

$\Rightarrow m = 3n$   $\leftarrow$  note that here  $n = (1, 2, 3, \dots)$   
 $m = (0, 1, 2, 3, \dots)$

$n=1$  for central bands  $\Rightarrow m=3$  is missing

$\Rightarrow m=1, 2$  are present.

$$(e+d) \sin \theta = m\lambda$$

$$\sin \theta_0 = 0 \Rightarrow \theta_0 = 0$$

$$(e+d) \sin \theta_1 = \pm 1 \cdot \lambda$$

$$\Rightarrow \sin \theta_1 = \pm \left(\frac{1}{6}\right) \Rightarrow \theta_1 = \pm \sin^{-1}\left(\frac{1}{6}\right)$$

$$(e+d) \sin \theta_2 = \pm 2 \cdot \lambda \Rightarrow \theta_2 = \pm \sin^{-1}\left(\frac{1}{3}\right)$$

3<sup>rd</sup> interference maxima

$$(e+d) \sin \theta_3 = \pm 3 \cdot \lambda \Rightarrow \theta_3 = \pm \sin^{-1}\left(\frac{1}{2}\right) \leftarrow \text{it goes missing}$$

1<sup>st</sup> diffraction minima

$$d \sin \theta_1 = \pm 1 \cdot \lambda \Rightarrow \theta_1 = \pm \sin^{-1}\left(\frac{1}{2}\right) \leftarrow$$



Also note fringe width of interference is const.

$$\beta = \frac{D\lambda}{(e+d)}$$

$$y_m = m \frac{D\lambda}{(e+d)}$$

$$y_{m+1} = (m+1) \frac{D\lambda}{(e+d)}$$

Note that  $\beta$  does not depend upon  
amplitude of the wave

## Multiple Slit Diffraction / Diffraction Grating

Arrangement of  $N$  equidistant parallel slits.

Based upon Fraunhofer Diffraction

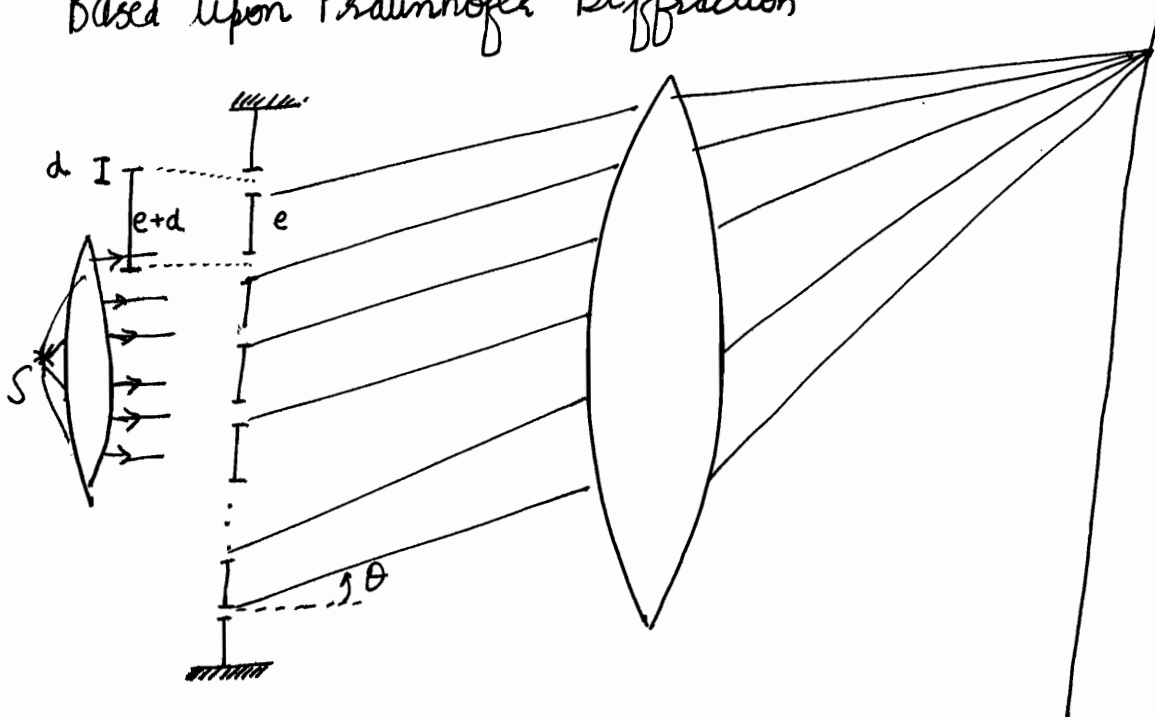

$$W = N(e+d)$$

$$\Rightarrow e+d = \left(\frac{W}{N}\right)$$

1 cm grating 5000 lines  
 $\Rightarrow e+d = \frac{1}{5 \times 10^5} \text{ m}$

Grating Element =  $e+d$  = Centre to Centre distance b/w any 2 slits

Interference of  $N$  diffracted rays.

$$R_i = \frac{A \sin \alpha}{\alpha}$$

$$\alpha = \frac{\pi}{\lambda} d \sin \theta$$

$$y_1 = R e^{-i\omega t}$$

$$y_2 = R e^{-i(\omega t + \phi)}$$

⋮

$$y_N = R e^{-i(\omega t + (N-1)\phi)}$$

$$\phi = \frac{(e+d) \sin \theta}{\lambda} \cdot 2\pi$$

$$\beta = \frac{\phi}{2} = \frac{\pi(e+d)}{\lambda} \sin \theta$$

$$\Rightarrow y = R e^{-i\omega t} \left[ \frac{1 - e^{-iN\phi}}{1 - e^{-i\phi}} \right]$$

$$= R e^{-i\omega t} \frac{e^{-i\frac{N\phi}{2}}}{e^{-i\frac{\phi}{2}}} \left[ \frac{\sin\left(\frac{N\phi}{2}\right)}{\sin\left(\frac{\phi}{2}\right)} \right]$$

$$= R e^{-i\left(\omega t + \frac{(N-1)\phi}{2}\right)} \frac{\sin\left(\frac{N\phi}{2}\right)}{\sin\left(\frac{\phi}{2}\right)}$$

$$= \left[ \frac{R \sin\left(\frac{N\phi}{2}\right)}{\sin\left(\frac{\phi}{2}\right)} \right] e^{-i\left(\omega t + \frac{(N-1)\phi}{2}\right)}$$

★ Remember that  $\beta$  is taken as  $\left(\frac{\phi}{2}\right)$

$$I = \dot{y} y^* = \frac{R^2 \sin^2\left(\frac{N\phi}{2}\right)}{\sin^2\left(\frac{\phi}{2}\right)}$$

and not  $\phi$

$$I = A^2 \frac{\sin^2 \alpha}{\alpha^2} \frac{\sin^2 (N\beta)}{\sin^2 \beta}$$

↑  
diffraction term

↑  
interference term

$$\alpha = \frac{\pi}{\lambda} d \sin \theta$$

$$\beta = \frac{\pi}{\lambda} (e+d) \sin \theta$$

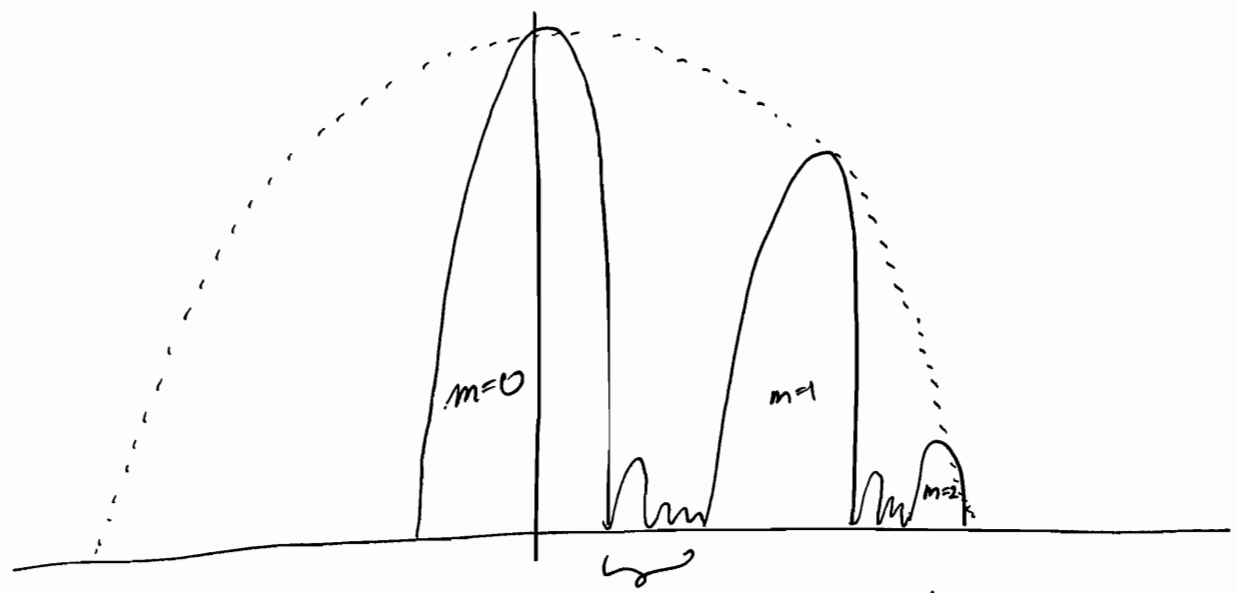

(N-1) minima b/w 2 successive

✓ PRINCIPAL interference maxima.....  
and

✓ SECONDARY (N-2) maxima b/w 2 successive principal interference maxima.

### Interference Maximas (Principal Maximas)

$$\beta = \pm n\pi ; n = 0, 1, 2, \dots$$

$$I_{max} = A^2 \frac{\sin^2 \alpha}{\alpha^2} \lim_{\beta \rightarrow \pm n\pi} \frac{\sin^2 N\beta}{\sin^2 \beta} = \frac{N^2 A^2 \sin^2 \alpha}{\alpha^2}$$

Grating Equation

$$(e+d) \sin \theta_n = n\lambda$$

$$n = 0, \pm 1, \pm 2, \dots$$

# Interference Minima

$$\sin^2 N\beta = 0$$

$$\Rightarrow N\beta = m\pi$$

For  $m=0$ : central interference maxima.

$m=N$ : 1<sup>st</sup> interference principal maxima

$\Rightarrow$  for  $m = (1, 2, 3, \dots, (N-1))$  : interference minima

$$\Rightarrow N\beta = m\pi$$

$$\Rightarrow N \frac{(e+d) \pi}{\lambda} \sin \theta = m\pi$$

$$\Rightarrow \boxed{(e+d) \sin \theta = \frac{m\lambda}{N}} \quad \text{for } m \in [1, N-1],$$

$[N+1, N+2, \dots, 2N-1],$   
 $[2N+1, 2N+2, \dots, 3N-1],$   
 $\vdots$

In between these  $(N-1)$  minimas, there will be  $(N-2)$  secondary interference maximas.

$\rightarrow$  In order to determine positions of secondary maximas, differentiate the intensity equation!!

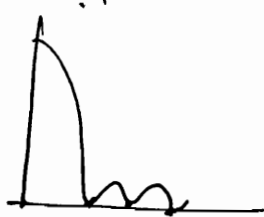

Find out position of 3<sup>rd</sup> interference minima adjacent to  $n^{\text{th}}$  order principal maxima...

$$\boxed{m = nN + 3}$$

$$(e+d) \sin \theta_m = n\lambda \quad ; \quad (e+d) \sin \theta_3 = \frac{3\lambda}{N}$$

$$\theta = \frac{3\lambda}{N(e+d)} + \frac{n\lambda}{(e+d)}$$

$$= \left( n + \frac{3}{N} \right) \left( \frac{\lambda}{e+d} \right)$$

## Secondary Maximas

$$I = \frac{A^2 \sin^2 \alpha}{\alpha^2} \frac{\sin^2 N\beta}{\sin^2 \beta}$$

$$\left. \frac{dI}{d\beta} \right|_{\beta=\beta_0} = 0$$

$$\left. \frac{d^2 I}{d\beta^2} \right|_{\beta=\beta_0} < 0$$

$$\sin^2 \beta \cdot \frac{d}{d\beta} (\sin(N\beta) \cos(N\beta) N) - \sin^2 N\beta \cdot \frac{d}{d\beta} (\sin \beta \cos \beta) = 0$$

Principal minima  
 $\frac{\sin N\beta = 0}{\sin \beta = 0}$   
 maxima

$$\Rightarrow N \sin \beta \cos N\beta = \cos \beta \sin N\beta$$

$$\Rightarrow N \left( \frac{\sin \beta_0}{\cos \beta_0} \right) = \left( \frac{\sin N\beta_0}{\cos N\beta_0} \right)$$

$$\Rightarrow \boxed{N \tan \beta_0 = \tan N\beta_0} \quad \checkmark$$

$\Leftrightarrow$

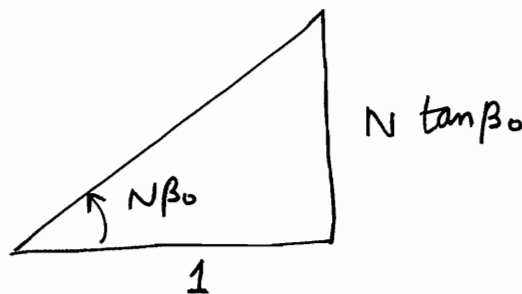

$$\Rightarrow \tan N\beta_0 = N \tan \beta_0$$

$$\frac{\sin^2 N\beta_0}{\sin^2 \beta_0} = \frac{N^2 \tan^2 \beta_0}{N^2 \tan^2 \beta_0 + 1} \cdot \frac{1}{(\sin^2 \beta_0)} = \frac{N^2}{(N^2 \sin^2 \beta_0 + \cos^2 \beta_0)}$$

$$\Rightarrow I_{\max} = \frac{N^2 A^2 \sin^2 \alpha}{\alpha^2 (\cos^2 \beta + N^2 \sin^2 \beta)}$$

$$= \frac{N^2 A^2 \sin^2 \alpha}{\alpha^2 (1 + (N^2 - 1) \sin^2 \beta)}$$

$$= \left[ \frac{I_{\text{Principal Max.}}}{1 + (N^2 - 1) \sin^2 \beta_0} \right] \leftarrow I_{\max} < I_{\text{Principal Max}}$$

$$I_{\text{Principal Max.}} = N^2 A^2 \left( \frac{\sin^2 \alpha}{\alpha^2} \right) \quad (\beta = m\pi)$$

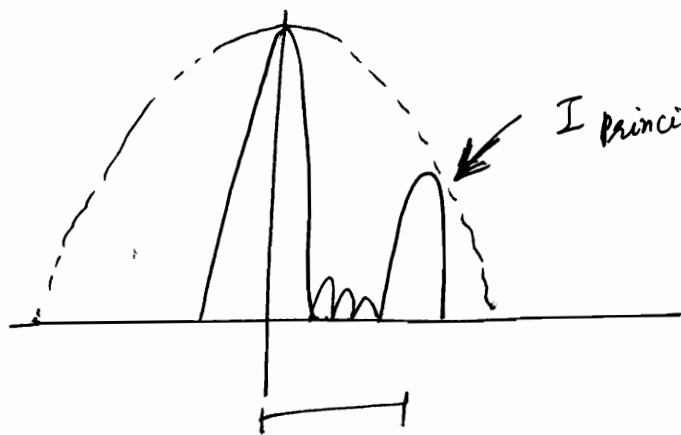

$I_{\text{Principle Max}}$  decreases due to change of  $\alpha$

Fringe Width can be found out

$$(e+d) \sin \theta = n\lambda$$

$$\Rightarrow \sin \theta = \frac{n\lambda}{e+d} = \left( \frac{y_n}{D} \right)$$

distance in between Principle maximas, hence comes out to be same as 2-slit diffraction.

$$\Rightarrow \boxed{\text{Fringe width} = \frac{D\lambda}{e+d}}$$

Q If used visible light, what is the maximum order that is seen distinctly.

Ans is 2

$$\lambda = 4000 - 7800 \text{ \AA}$$

$$(e+d) \sin \theta = n\lambda$$

⊛ Grating में यही equation लगानी है i.e. equation for Principal maxima.

1<sup>st</sup> order  $\theta = \frac{\lambda}{(e+d)}$  :  $\frac{4000}{e+d}$  to  $\frac{7800}{e+d}$  ✓

2<sup>nd</sup> order  $\theta = \frac{8500}{e+d}$  to  $\frac{15600}{e+d}$



3<sup>rd</sup> order  $\theta = \frac{12000}{e+d}$  to  $\frac{23400}{e+d}$  : Overlap

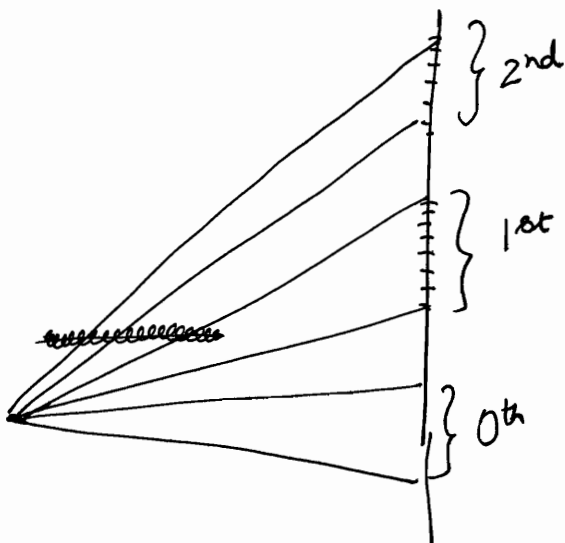

0<sup>th</sup>, 1<sup>st</sup>, 2<sup>nd</sup> : seen

3<sup>rd</sup> overlaps, hence not clear

ज्यादा दिमाग नहीं,  
Visible light range =  
4000 - 7000 \AA

⊛ In the double-slit diffraction experiment the angular spread of central diffraction maxima is  $2\sin^{-1}\left(\frac{\lambda}{d}\right)$

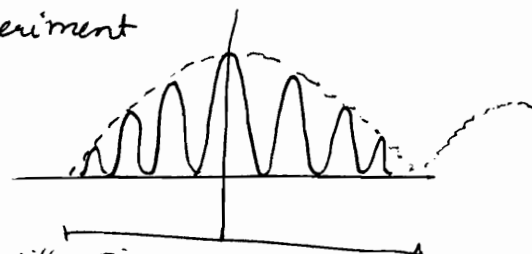

If  $d \ll \lambda \Rightarrow$  1 slit acts as point source of light & no diffraction  $\Delta\theta = 2\sin^{-1}\left(\frac{\lambda}{d}\right)$   
 $\Rightarrow$  one simply obtains Young's double slit experiment.

⊛ Plot of  $\frac{\sin^2 N\beta}{\sin^2 \beta}$

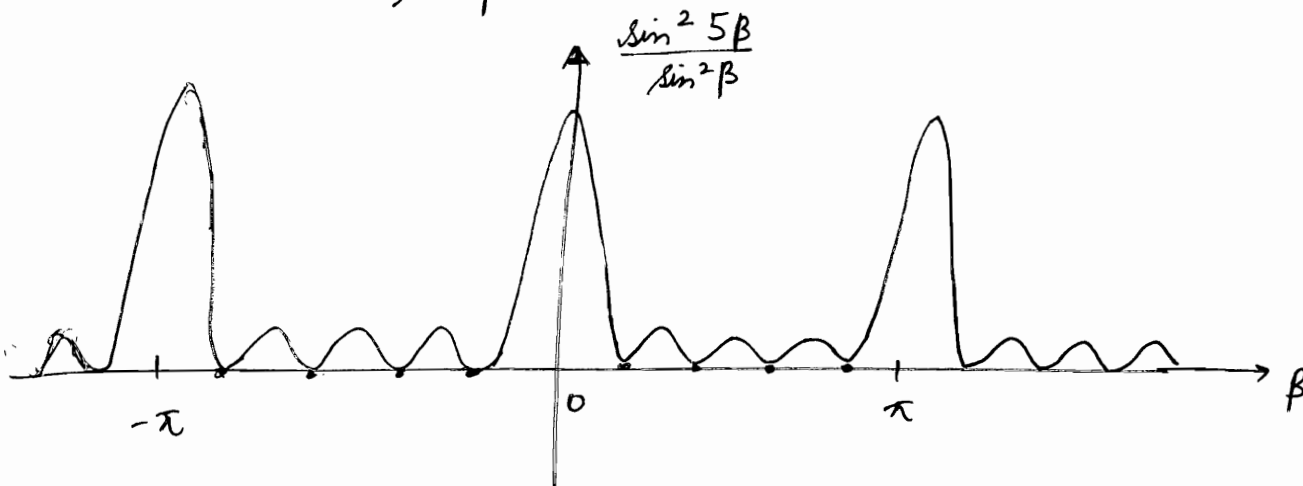

⊛ Principal Maximas at  $\beta = n\pi$  ( $n = 0, \pm 1, \pm 2, \dots$ )

$$\lim_{\beta \rightarrow m\pi} \frac{\sin N\beta}{\sin \beta} = \lim_{\beta \rightarrow m\pi} \frac{N \cdot \cos N\beta}{\cos \beta} = \pm N$$

⊛ Now Intensity = 0 when,  $\beta = \frac{m\pi}{N}$   $\begin{matrix} m \neq 0 \\ m \neq \pm N, \pm 2N \end{matrix}$

$\therefore$  between 2 principal maxima, we have  $(N-1)$  minima.

⊛ Between two such consecutive minima, we must have a maximum, these maximas are called secondary maximas.  $\therefore (N-2)$  secondary maximas.

A particular principal maximum may be absent if it corresponds to the angle which also determines the minimum of single-slit diffraction pattern.

$$\left. \begin{array}{l} \text{i.e. } d\sin\theta = m\lambda \\ (e+d)\sin\theta = \lambda, 2\lambda, 3\lambda, \dots \end{array} \right\} \text{ are satisfied simultaneously.}$$



# OPTICS (13)

19/12/2011

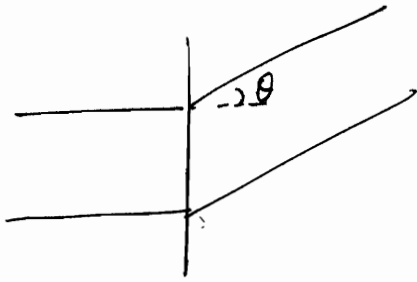

$$\Delta = (e+d) \sin \theta$$

If oblique incidence,

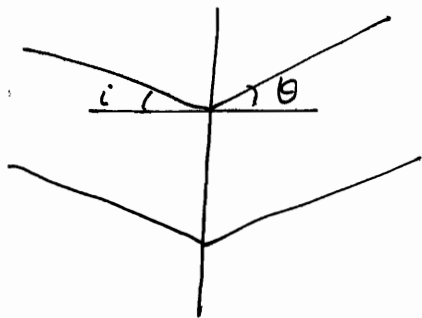

$$\Delta = (e+d)(\sin \theta + \sin i)$$

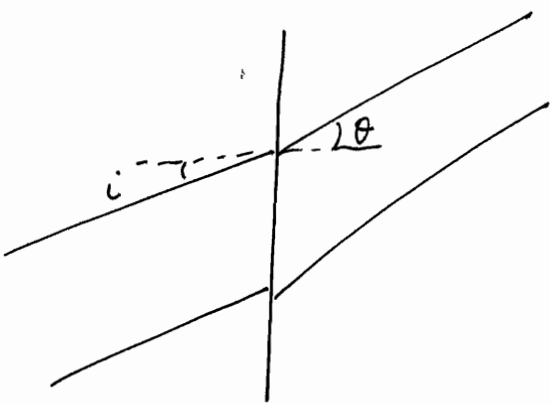

$$\Delta = (e+d)(\sin \theta - \sin i)$$

→ Generalized condition:

$$e+d(\sin \theta \pm \sin i) = n\lambda$$

for maxima condition !!

$$n = \frac{(e+d) \sin \theta}{\lambda}$$

## Resolving Power

Every source has some spectral width....

Ability of the optical instrument to discriminate  $\lambda/\Delta\lambda$  2 images of closely wavelengths, is called Resolving Power or Chromatic Resolving Power

$$\text{Resolving Power} = \left( \frac{\lambda}{\Delta\lambda} \right)$$

## Rayleigh's Criteria

"2 closely wavelengths,  $\lambda$  and  $\lambda + \Delta\lambda$  are said to be resolved if maxima of one corresponds to minima of other wavelength, and vice versa."

(If we have maxima & minima far apart, then we use another criteria of half intensities eg. Feby Perot Interferometer)

Resolvable

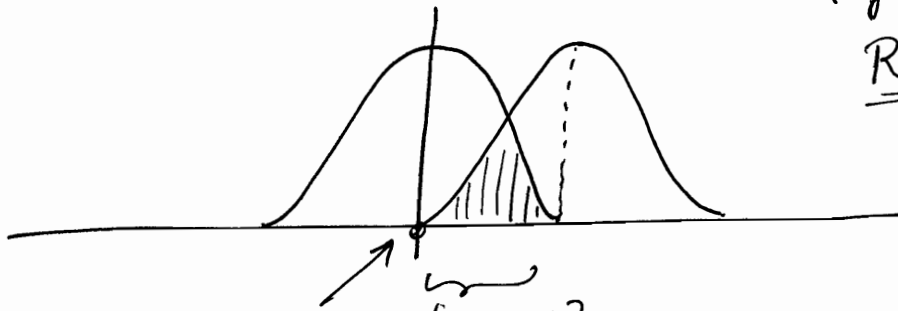

Maxima of  $\lambda$  corresponds [overlap] with minima of  $(\lambda + \Delta\lambda)$

If overlap is more, then no longer resolvable.

## Resolving Power of Grating

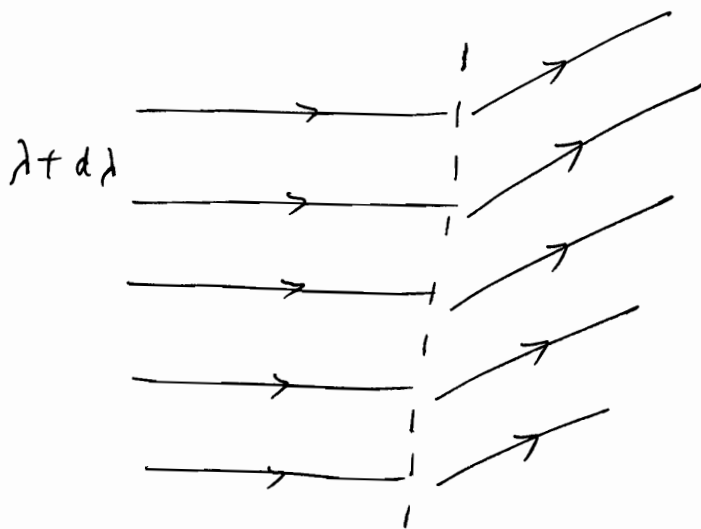

$$w = N(e+d)$$

## Diffraction Grating or Transmission Grating

Let us say,  $n^{\text{th}}$  order maxima of the grating occurs at angle  $\theta$  for wavelength  $\lambda$ .

$$\Rightarrow (e+d) \sin \theta = n\lambda$$

for wavelength  $(\lambda + d\lambda)$

$$(e+d) \sin(\theta + d\theta) = n(\lambda + d\lambda)$$

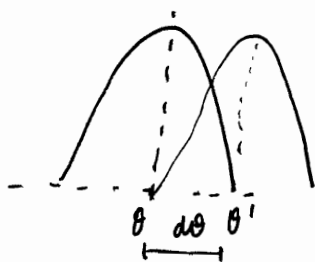

1<sup>st</sup> minima after  $n^{\text{th}}$  Principal Maxima

$$(e+d) \sin \theta' = n\lambda + \frac{\lambda}{N}$$

, for  $\lambda$  (minima)

Now applying Rayleigh's Criteria....

$$\Rightarrow (e+d) \sin \theta' = n\lambda + n d\lambda$$

(maxima)

$$\Rightarrow \frac{\lambda}{N} = n d\lambda \Rightarrow$$

$$\frac{\lambda}{d\lambda} = nN$$

Resolving Power, so obtained is called Geometrical Resolving Power. Its characteristic of device.

while

Chromatic Resolving Power is characteristic of source.

If Geometrical Resolving Power  $\geq$  Chromatic Resolving Power

$\Rightarrow$  Resolvable by the particular device.

101

1 cm width & 500 lines per cm.

illuminated by sodium source:  $5890 \text{ \AA}$   
 $5896 \text{ \AA}$

Minima Resolving Power reqd.  $\frac{\lambda}{\Delta\lambda} = \frac{5893}{6} = 981$

by device to form resolvable patterns.

In 1<sup>st</sup> order: R.P. =  $nN = 1.500 = 500$

2<sup>nd</sup> order: R.P. =  $2.500 = 1000$

Hence can be resolved in 2<sup>nd</sup> order.

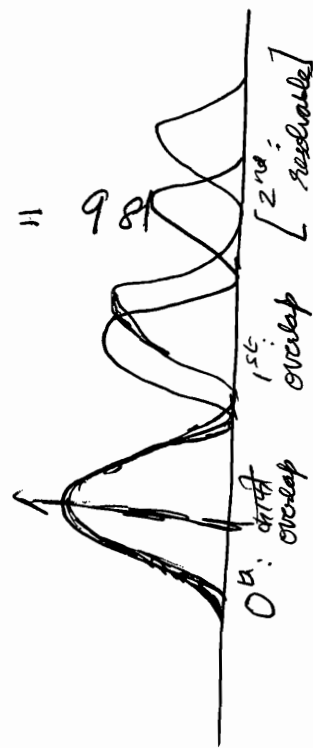

Limit of Resolution :- Angular separation  $1/w$  just resolvable images.

Limit of Resolution  $\propto \frac{1}{\text{Resolving Power}}$

$$\text{Resolving Power} = \frac{1}{\text{Limit of Resolution}}$$

## Fraunhofer Diffraction due to Circular Aperture

eg. lens of telescope.

defined by ~~radius~~ radius 'a'.

Till now we considered 1-d only.

It is 2-d now.

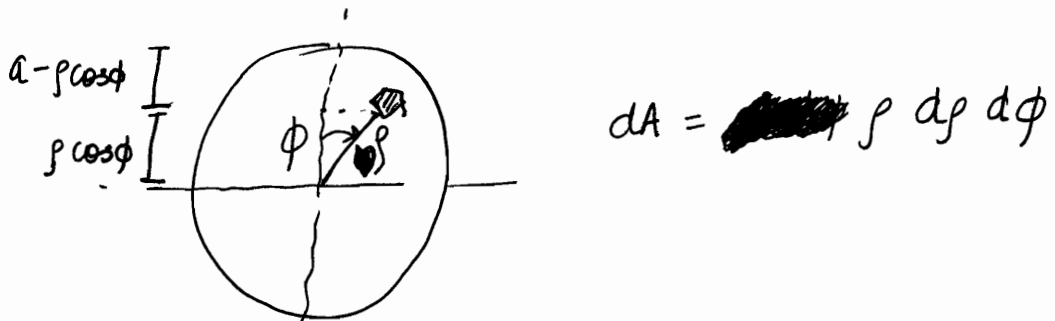
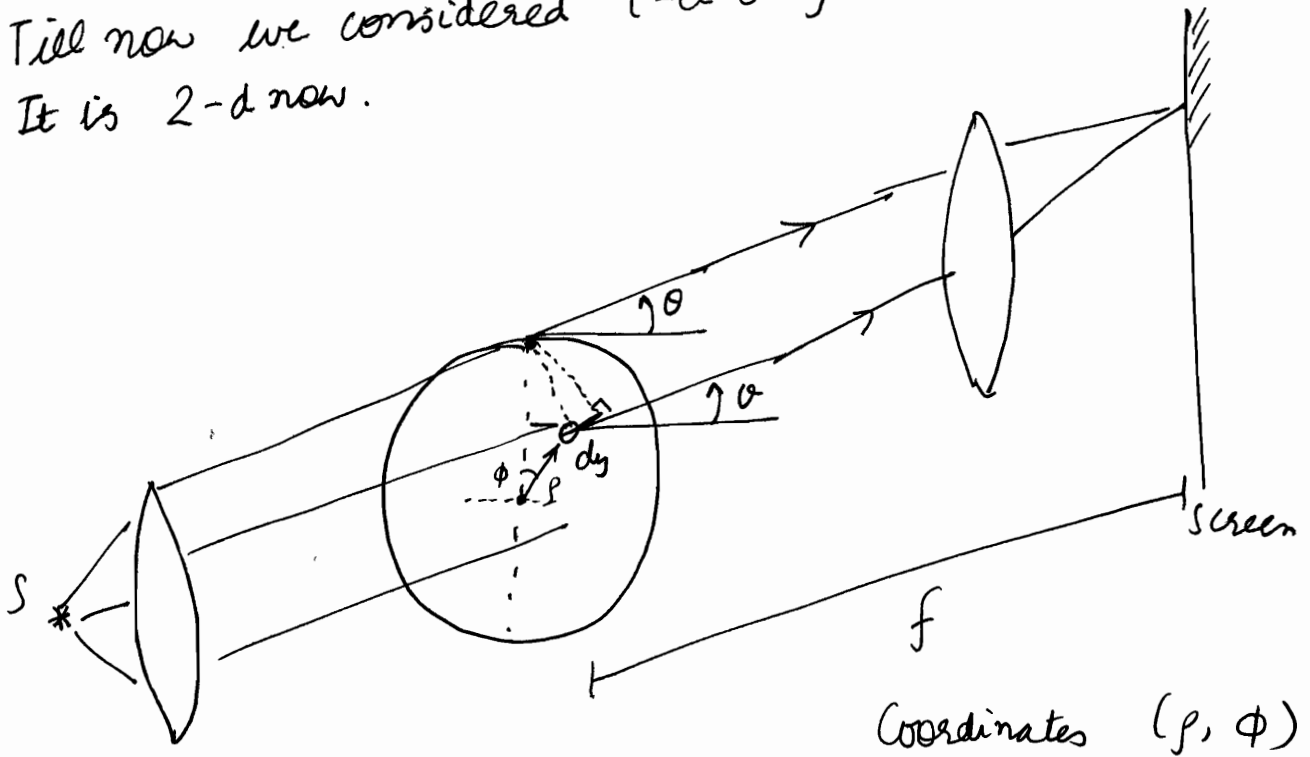

$$dA = \rho d\rho d\phi$$

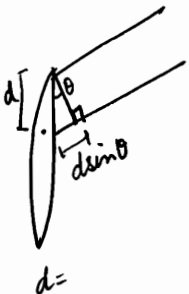

$$\Delta = (a - \rho \cos \phi) \sin \theta$$

[absolutely correct]

$$dy = (k e^{-i(\omega t + \phi)}) \left( \frac{p d\phi dp}{\lambda} \right) \quad [\phi \text{ w.r.t. periphery}]$$

$$y = A e^{-i\omega t}$$

Also we can write

$$y = A \sin \omega t$$

$$dy = k \sin(\omega t + \phi) \frac{p d\phi dp}{\lambda} = k \sin\left(\omega t + \frac{2\pi}{\lambda} (a - r \cos\phi) \sin\theta\right) \frac{p d\phi dp}{\lambda}$$

$$\Rightarrow dy = k \sin\left(\omega t - \frac{2\pi}{\lambda} a \sin\theta + \frac{2\pi}{\lambda} r \sin\theta \cos\phi\right) \frac{p d\phi dp}{\lambda}$$

$$= k \sin\left(\omega t - \frac{2\pi}{\lambda} a \sin\theta\right) \frac{p d\phi dp}{\lambda} \cos\left(\frac{2\pi}{\lambda} r \sin\theta \cos\phi\right)$$

$$+ \frac{p d\phi dp}{\lambda} \cos\left(\omega t - \frac{2\pi}{\lambda} a \sin\theta\right) \sin\left(\frac{2\pi}{\lambda} r \sin\theta \cos\phi\right)$$

$$y_{\text{Total}} = \int dy$$

$$= \int_0^{2\pi} \int_0^a dy$$

$$= k \sin\left(\omega t - \frac{2\pi}{\lambda} a \sin\theta\right) \int_0^{2\pi} \int_0^a \frac{p}{\lambda} \cos\left(\frac{2\pi}{\lambda} r \sin\theta \cos\phi\right) d\phi dr$$

$$+ k \cos\left(\omega t - \frac{2\pi}{\lambda} a \sin\theta\right) \int_0^{2\pi} \int_0^a \frac{p}{\lambda} \sin\left(\frac{2\pi}{\lambda} r \sin\theta \cos\phi\right) d\phi dr$$

Odd function of  $\phi \Rightarrow$  vanish

$$\Rightarrow y = k \sin \left( \underbrace{\omega t - \frac{2\pi}{\lambda} a \sin \theta}_{\text{phase}} \right) \underbrace{\int \int \rho \cos \left( \rho \frac{2\pi}{\lambda} \sin \theta \cos \phi \right) d\rho d\phi}_{\text{amplitude}}$$

$$A = k \int_0^{2\pi} \int_0^a \rho \cos \left( \rho \frac{2\pi}{\lambda} \sin \theta \cos \phi \right) d\rho d\phi$$

$$z = \frac{2\pi}{\lambda} \sin(\theta) \cdot a = \frac{\pi}{\lambda} d \sin \theta$$

$\uparrow$  radius                       $\uparrow$  diameter

$$A = \frac{J_1(z)}{z} \leftarrow [\text{Bessel Function}]$$

$$I_p = c_1 \left( \frac{J_1(z)}{z} \right)^2$$

where  $z = \frac{\pi}{\lambda} d \sin \theta$   
 $\rightarrow J_1(x)$  is a function whose ~~function~~ behaviour is similar to sine function....

$d$ : diameter of aperture

### Central Maxima:

$$\theta = 0 \text{ i.e. } z = 0 \Rightarrow I_0 = c_1 \left( \frac{J_1(0)}{0} \right)^2 = c_1 \cdot 1 = c_1$$

$$\Rightarrow I_p = I_0 \left( \frac{J_1(z)}{z} \right)^2$$

✓ Pattern due to circular aperture is concentric rings!!

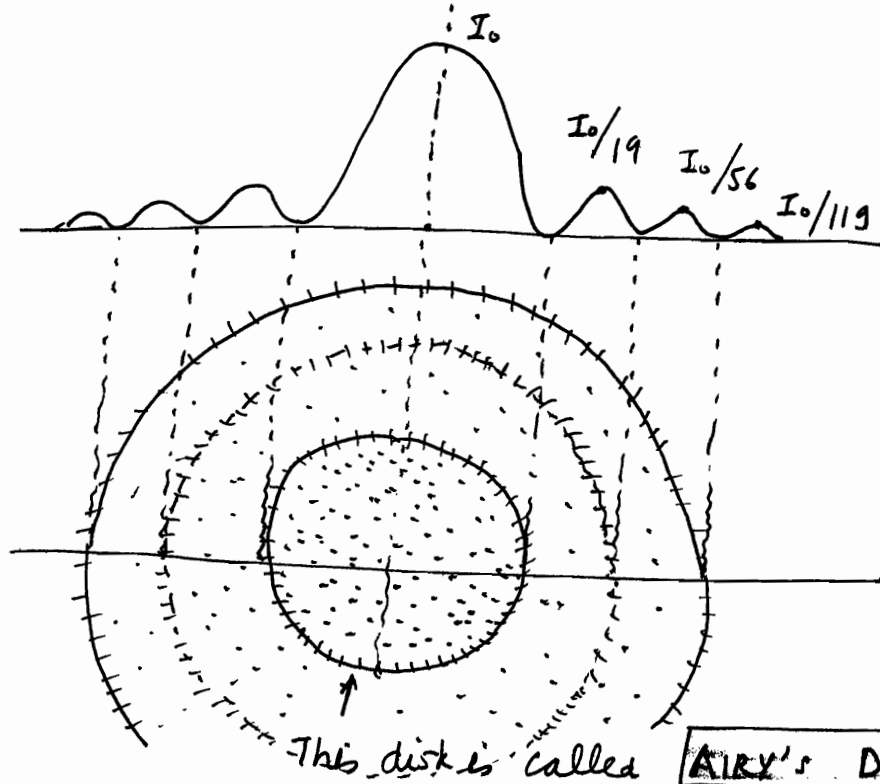

84% of light is concentrated here.  
 [total energy on screen]

$$\frac{dI_1(z)}{dz} = J_2(z)$$

verified from Ghatak all these values  
~~.....~~  
~~.....~~  
~~.....~~  
~~.....~~  
~~.....~~

For minima,

$$\frac{\pi}{\lambda} d \sin \theta = 1.22 \pi$$

$$\Rightarrow d \sin \theta = 1.22 \lambda$$

diameter of aperture

Half Angular Spread of Central Bright Fringe

$$= \sin^{-1} \left( 1.22 \frac{\lambda}{d} \right)$$

Radial Spread  $y_1 = 1.22 \frac{\lambda}{d} * f$

MINIMAS

$$z_1 = 1.22 \pi$$

$$z_2 = 2.238 \pi$$

$$z_3 = 3.23 \pi$$



2<sup>nd</sup> Minima

$$\underline{d \sin \theta_{m_2} = 2.233 \lambda}$$

3<sup>rd</sup> minima

$$d \sin \theta_{m_3} = 3.238 \lambda$$

Let us take Maximas as average of Minimas.

$$Z_{\text{Max}_1} = 1.635 \pi \quad \therefore \left( \frac{I_0}{56} \right)$$

$$Z_{\text{Max}_2} = 2.679 \pi \quad \therefore \left( \frac{I_0}{119} \right)$$

$$\underline{d \sin \theta_{M_1} = 1.635 \lambda}$$

$$\underline{d \sin \theta_{M_2} = 2.679 \lambda}$$

Telescope Objective lens : Resolving Power

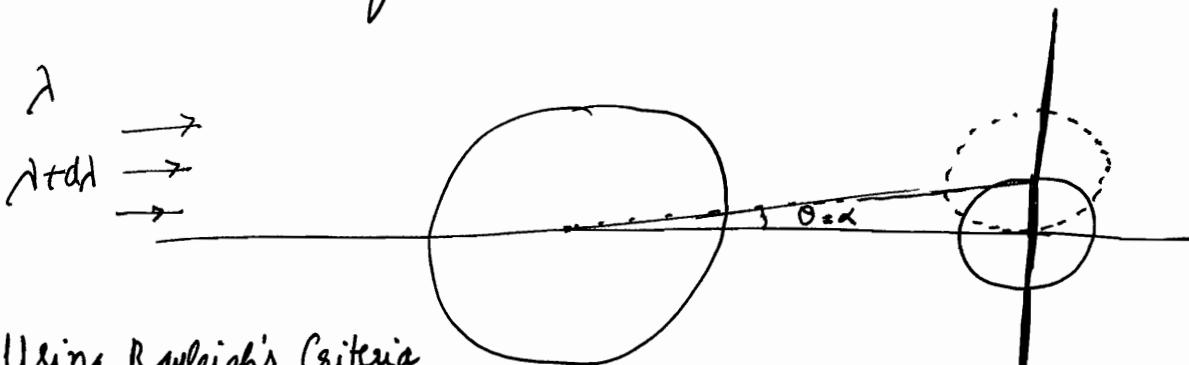

Using Rayleigh's Criteria,

$$\text{Limit of Resolution, } \alpha = \theta = \sin^{-1} \left( \frac{1.22 \lambda}{d} \right) \approx \frac{1.22 \lambda}{d}$$

$$\boxed{\text{Resolving Power} = \frac{1}{\alpha} = \left[ \frac{d}{1.22 \lambda} \right]}$$

# Laser beam : Focussing

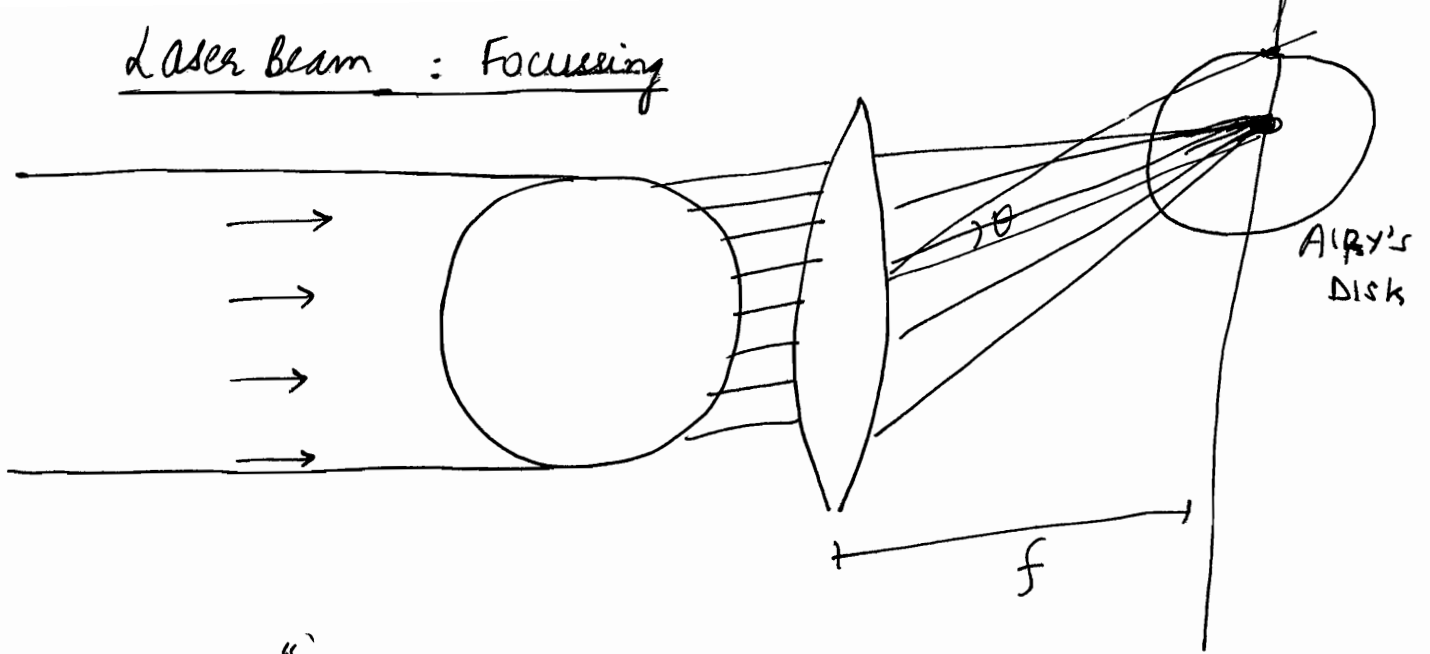

Laser is "diffraction limited"

For spread of Central Diffraction Maxima

|                |                                          |
|----------------|------------------------------------------|
| Angular Spread | $\sin \theta_c = \frac{1.22 \lambda}{d}$ |
|----------------|------------------------------------------|

Radial Spread =  $\frac{1.22 f \lambda}{d}$   
( $y_r$ )

Areal Spread =  $\pi y_r^2$

|                            |                                                   |
|----------------------------|---------------------------------------------------|
| Intensity at focussed spot | $I = \frac{0.84 P_{laser}}{\text{Radial Spread}}$ |
|----------------------------|---------------------------------------------------|

For focussing of laser, we usually do not use Airy disk

To calculate  $r_0$ , use



$$r_0 = \frac{\lambda f}{2 r_{beam}}$$

(ie. instead of '1.22', use '2')  
and forget 84%

$$\Rightarrow \text{Area} = \pi r_0^2$$

$$\Rightarrow \text{Intensity} = \left( \frac{P}{\text{Area}} \right)$$

★ Grating Equation  $\beta = m\pi$  for Principal Maxima

$$\frac{\pi(e+d)\sin\theta}{\lambda} = m\pi$$

$$\Rightarrow \boxed{(e+d)\sin\theta = m\lambda}$$

Hence  $m$  cannot be arbitrarily large, as  $\frac{m\lambda}{e+d} \leq 1 \Rightarrow m \leq \left(\frac{e+d}{\lambda}\right)$

★ Grating Spectrum

$(e+d)\sin\theta = m\lambda$ , [For principal maxima of  $m^{\text{th}}$  order]

Grating equation can be used to study the dependence of angle of diffraction  $\theta$  on wavelength  $\lambda$ . Zeroth order principal maxima occurs at  $\theta=0$  irrespective of wavelength.

However for  $m \neq 0$ , angles of diffraction are different for different wavelengths and therefore, various spectral components appear at different positions. Thus by measuring angle of diffraction for various colours, one can determine values of wavelengths.

Also  $\frac{\Delta\theta}{\Delta\lambda} = \frac{m}{(e+d)\cos\theta}$  (differential form of grating equation)

For small  $\theta$ ,  $\Delta\theta = \left[\frac{m}{e+d}\right] \Delta\lambda$

Also called dispersive power

$\Delta\theta \propto m$ , i.e. order of spectrum

$\Delta\theta \propto \frac{1}{e+d}$ , i.e. larger angular dispersion if less  $(e+d)$   
i.e. more  $N$

○ Basically, for different  $\lambda$ , principal maxima occur at different  $\theta$ . This is angular dispersion. Due to different location, we are able to distinguish between images.

★ Resolving Power of Grating

$$(e+d)\sin\theta' = m(\lambda + \Delta\lambda)$$

$$(e+d)\sin\theta' = m\lambda + \frac{\lambda}{N}$$

$$\Rightarrow R = \frac{\lambda}{\Delta\lambda} = \underline{\underline{mN}}$$

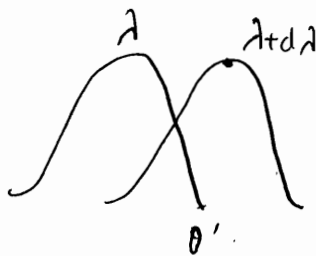

$\rightarrow \left(\frac{\Delta\theta}{\Delta\lambda}\right)$  is positive

i.e. ज्यादा  $\lambda$  के लिए Principal maxima का  $\theta$  ज्यादा होगा !!

which implies that the resolving power depends on total number of lines in the grating and order of spectrum.

Thus to resolve  $D_1$  and  $D_2$  lines of sodium in 1<sup>st</sup> order,

$$N = \frac{1}{m} \frac{\lambda}{\Delta\lambda} = \frac{1}{1} \frac{5893}{6} \approx 1000$$

Note that if  $N$  is increased, ( $\Delta\lambda$ ) reduces and upper bound of  $m_2$  drops. Hence Resolving Power can't be arbitrarily increased by increasing  $N$ .

⊛ Also note that  $N$  refers to those slits that are exposed to incident beam. Only a finite width  $W$  can be exposed to incident beam.

### ⊛ CIRCULAR APERTURE

$$\theta_m : \text{half angular spread} = \sin^{-1} \left( \frac{1.22 \lambda}{d} \right)$$

ie.  $\theta_{\text{spread}} \propto \left( \frac{1}{d} \right)$  (for all diffractions)

even in Heisenberg's experiment

This has an interesting application. A layman would think that in order to obtain more directionality of sound waves, one should use a loudspeaker of small aperture; however this will result in greater diffraction divergence. If one uses a loudspeaker of larger diameter, greater directionality is achieved.

### ⊛ Limit of Resolution for Telescope

Consider light coming from two stars being focussed by telescope objective

Each star will produce its own Airy pattern. Since radius of first

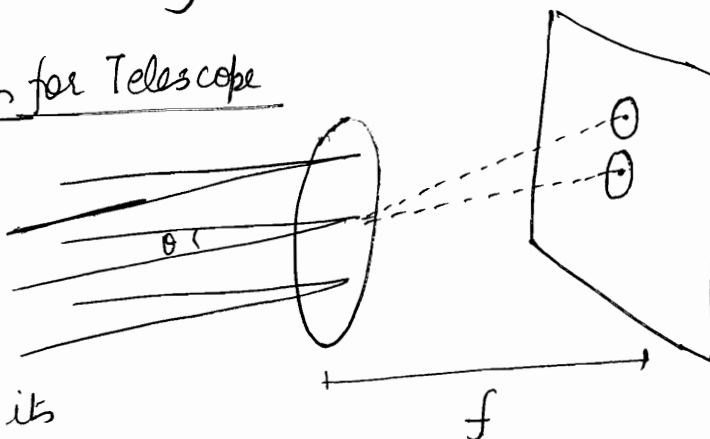

in each airy pattern is  $1.22 \frac{\lambda f}{D}$ , the airy patterns will overlap more for smaller values of  $D$  and hence for better resolution, one requires a larger diameter of the objective.  $\therefore$  better diameter  $\rightarrow$  better telescope. Also larger aperture provides a larger light gathering power and ability to see deeper into space.

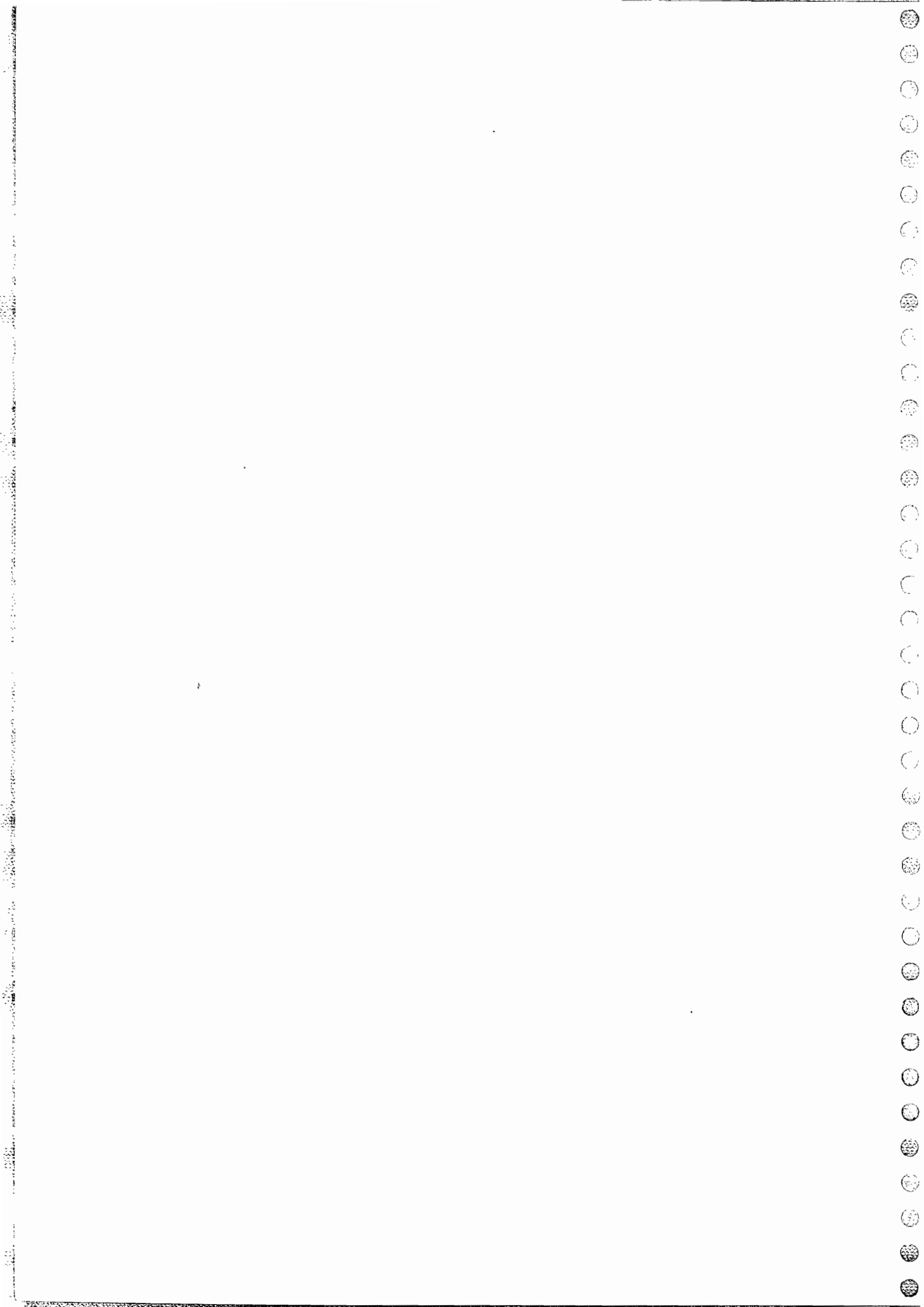

# ★ Airy Pattern

In the diffraction from circular aperture  
 Because of rotational symmetry of the system, the diffraction pattern will consist of concentric dark & bright rings

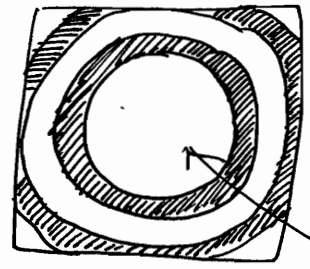

84%  
 of the  
 light power

$$I = I_0 \left( \frac{J(\alpha)}{\alpha} \right)^2$$

$$\alpha = \frac{\pi d \sin \theta}{\lambda}$$

where  $d$  is diameter of aperture  
 $\theta$  is angle of diffraction.

$J(\alpha)$  is Bessel function, variation of Bessel function is something like a damped sine wave.

Take the maxima angles at mid point point of minima angles.

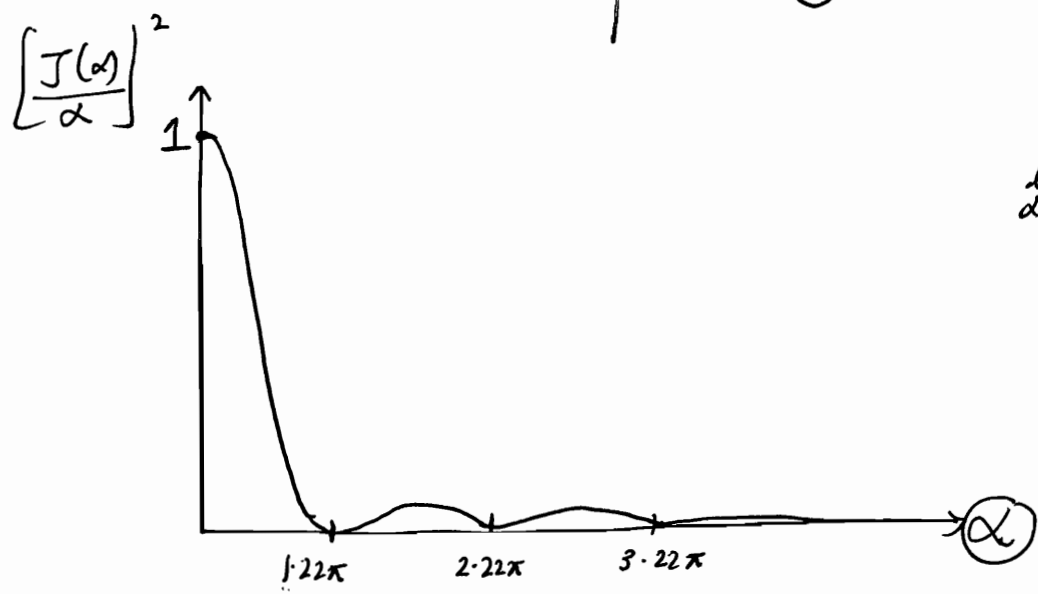
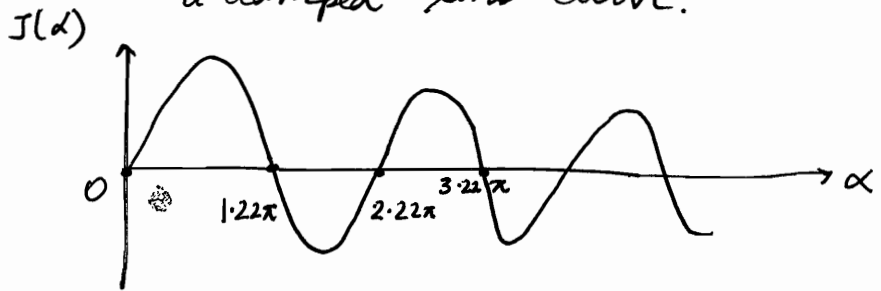

$$\lim_{\alpha \rightarrow 0} \left( \frac{J(\alpha)}{\alpha} \right) = 1$$

22



# OPTICS (14)

20/12/2011

- ⊙ HPZ
- ⊙ Zone Plate
- ⊙ Straight Edge

## Fresnel Diffraction

This diffraction is explained by Fresnel-Huygens Theory. Here the distances are finite. Hence any type of wavefront can be used. No lenses are required.

Modification of Huygens Theory by Fresnel :-

①  $\rightarrow y_n \propto$  Area of the corresponding (half period zone)

②  $\rightarrow$  There is no backward propagation. This is called  
OBLIQUITY FACTOR :  $(1 + \cos\theta)$

$\Rightarrow y_n \propto$  Obliquity factor

③  $\rightarrow y_n \propto \frac{1}{\text{(distance from zone where intensity is desired)}}$

④  $\rightarrow y = \sum y_n = \sum \frac{\text{(Area of zone)} * \text{(Obliquity factor)}}{\text{(distance from source)}}$

## Half Period Zones

Let us assume plane wavefront

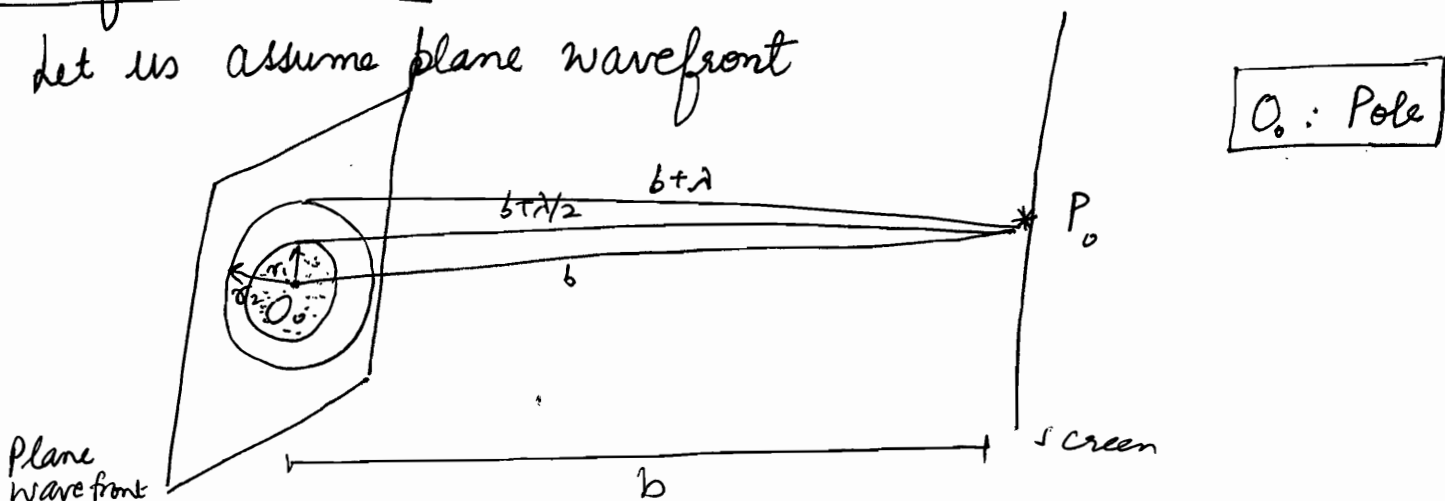

With  $P_0$  as centre, draw spheres of radius

$$b_n = b + n \frac{\lambda}{2}$$

$$n = 0, 1, 2, \dots$$

$$\Rightarrow S_n P = S_{n+1} P = \left(\frac{\lambda}{2}\right)$$

$$r_1 = \sqrt{\left(b + \frac{\lambda}{2}\right)^2 - b^2}$$

$$r_1 = \sqrt{b\lambda}$$

$$r_2 = \sqrt{(b + \lambda)^2 - b^2}$$

$$\Rightarrow r_i \propto \sqrt{i}$$

Where  $r_i$  is the radius as measured from Pole.

$$r_2 = \sqrt{2b\lambda}$$

$$r_n = \sqrt{nb\lambda}$$

$k^{\text{th}}$  half period zone = [Concentric or Annular] Area between  $k^{\text{th}}$  and  $(k-1)^{\text{th}}$  circle

$$\begin{aligned} \text{Area of } k^{\text{th}} \text{ half period zone} &= \pi r_k^2 - \pi r_{k-1}^2 \\ &= \pi [kb\lambda - (k-1)b\lambda] \end{aligned}$$

$$\boxed{A_{HPZ} = \pi b\lambda}$$

$\Rightarrow$  Area of all half period zones is same.....

[Since  $\Delta = \left(\frac{\lambda}{2}\right)$  between any 2 consecutive zones,  $\Rightarrow$   $\Delta\phi = \pi$ , hence called Half Period zones.]

$\therefore$  contribution of consecutive HPZ is opposite

 all contribute positively towards  $\rightarrow$

$$b_n = \frac{\left[ b + \frac{n\lambda}{2} \right] + \left[ b + \frac{(n-1)\lambda}{2} \right]}{2} = b + \frac{(2n-1)\lambda}{4}$$

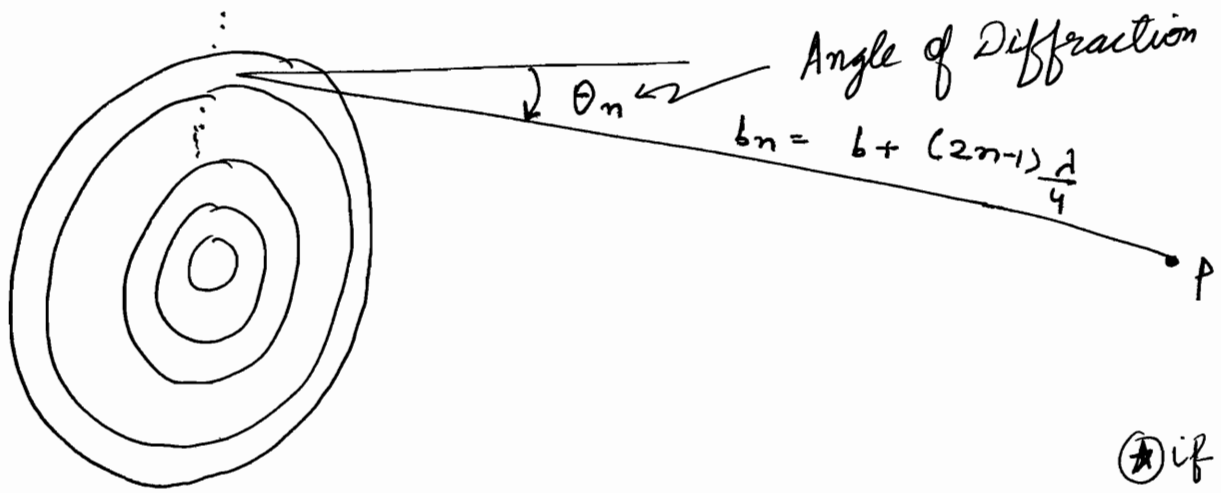

Contribution from half period zone

$$y_n = \frac{(\pi b \lambda) (1 + \cos \theta_n)}{b + \frac{(2n-1)\lambda}{4}}$$

⊛ if  $n \uparrow$   
 $\theta_n \uparrow$  &  $n \uparrow$   
 $\cos \theta_n \downarrow$   
 $\Rightarrow y_n \downarrow$

→ Wavelets starting from various HPZ are called Secondary wavelets.....

- Maximum Contribution from 1<sup>st</sup> HPZ  $\because n=1, \theta=0$
- Minimum Contribution from last HPZ.

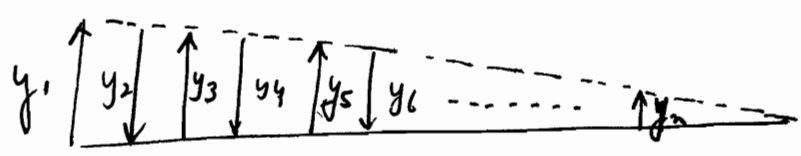

$$y = \sum_i y_i = (y_1 + y_3 + y_5 + \dots) - (y_2 + y_4 + y_6 + \dots)$$

$$y = \sum_{n=1}^N (-1)^{n-1} y_n$$

$$y_2 \approx \frac{y_1 + y_3}{2}$$

$$y_4 \approx \frac{y_3 + y_5}{2}$$

$$\Rightarrow y_n = \frac{y_1}{2} + \left( \frac{y_1}{2} - y_2 + \frac{y_3}{2} \right) + \left( \frac{y_3}{2} - y_4 + \frac{y_5}{2} \right) + \frac{y_5}{2} \dots$$

$$\Rightarrow \boxed{\begin{aligned} y &= \frac{y_1}{2} + \frac{y_n}{2} && \text{if } n: \text{ odd} \\ y &= \frac{y_1}{2} + \frac{y_{n-1}}{2} - y_n && \text{if } n: \text{ even} \end{aligned}}$$

At large  $n$ ,  $y_{n+1} \approx y_n$

$$\Rightarrow \boxed{\begin{aligned} y &= \frac{y_1}{2} + \frac{y_n}{2} && n: \text{ odd} \\ y &= \frac{y_1}{2} - \frac{y_n}{2} && n: \text{ even} \end{aligned}}$$

At extremely large  $n$ ,  $y_n \approx 0$

$$\Rightarrow \boxed{\begin{aligned} y &= \frac{y_1}{2} && n: \text{ odd} \\ y &= \frac{y_1}{2} && n: \text{ even} \end{aligned}}$$

$\frac{y_1}{2}$  corresponds to  $I_0$

..... Application in policy .....

Fresnel  
 Diffraction due to straight edge

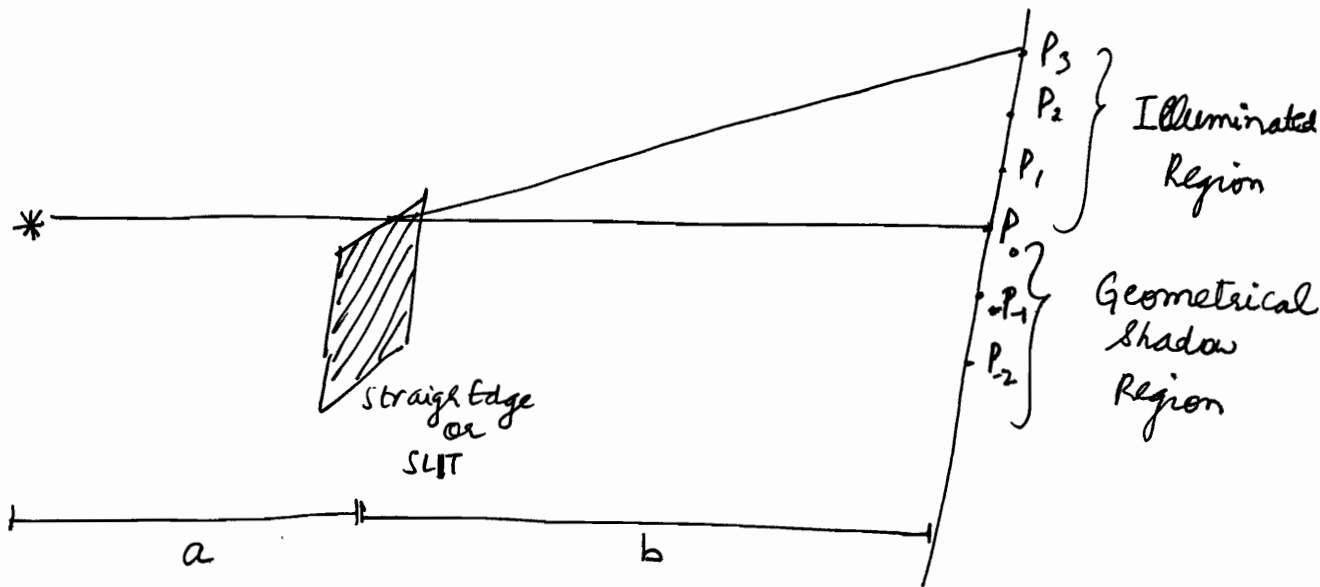

- ✓ Alternate maxima and minima in illuminated region.
- ✓ Intensity falls monotonously in geometrical shadow region.

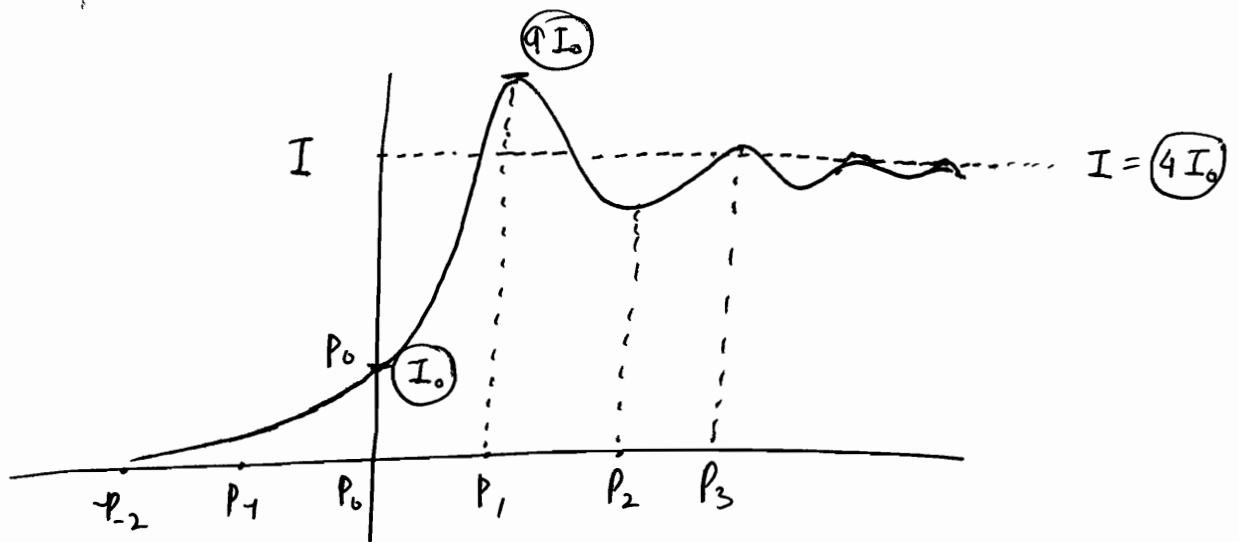

Distance between maxima in illuminated zone is non-uniform

This pattern is explained by Fresnel-Huygen Wave Theory.

Illuminated Region.

do from end of lecture

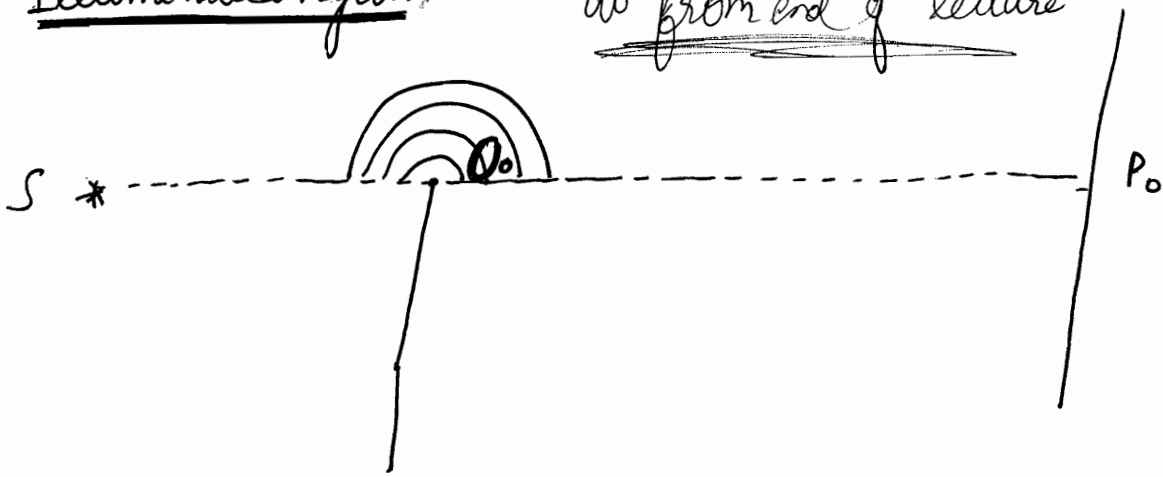

Actually  $(\frac{y_0}{4})$

let  $y_0 = (\frac{y_0}{2})$   
 $\Rightarrow (\frac{y_0}{2})$

$$y_{P_0} = \left(\frac{y_0}{2}\right)$$

$$\Rightarrow I_{P_0} = \left(\frac{y_0^2}{4}\right) = \left(\frac{I_0}{4}\right), \text{ let say } I_0 = y_0^2$$

(यही निकाल है)

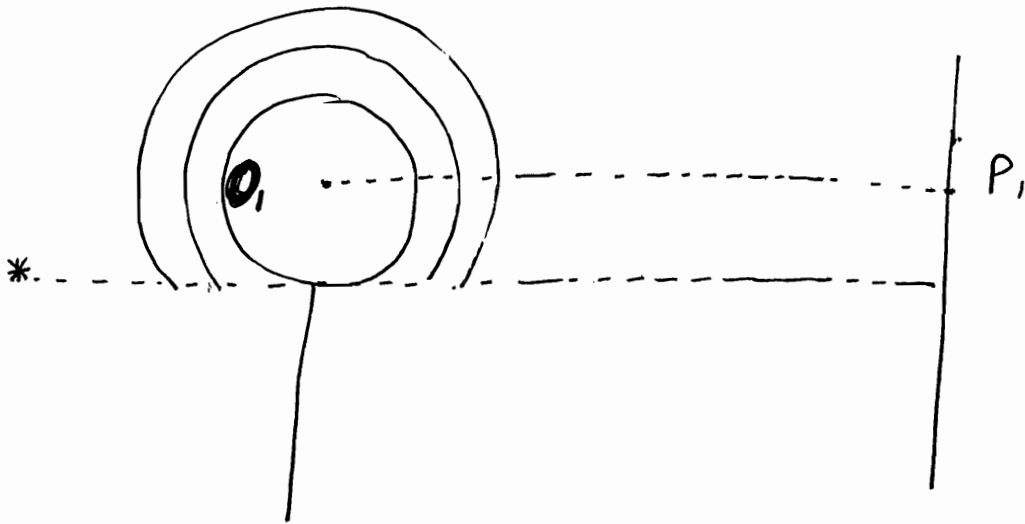

$$y_{P_1} = \left(\frac{y_1}{2}\right)_{\text{upper half}} + (y_1)_{\text{lower half}} = \left(\frac{3}{2}\right)y_1$$

brightest spot

$$\Rightarrow I_{P_1} = \frac{9}{4} y_1^2 = \frac{9}{4} I_0 = \underline{\underline{9 I_{P_0}}}$$

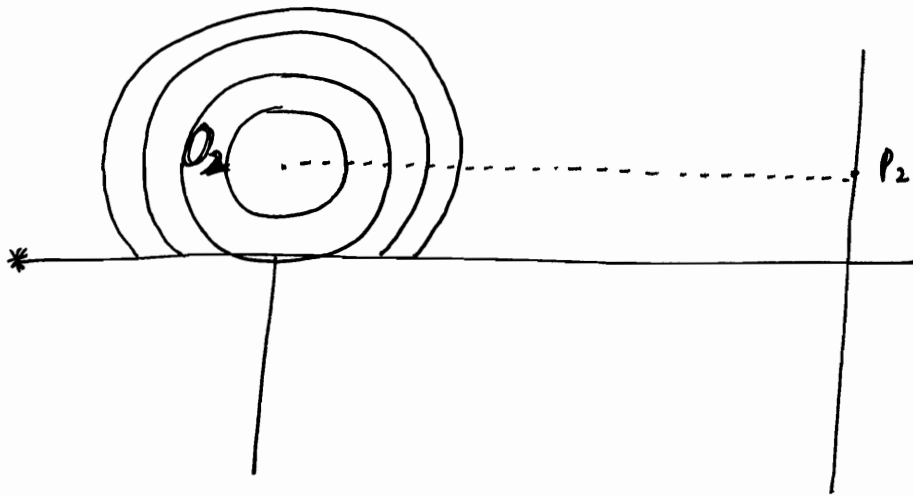

$$y_{P2} = \left(\frac{y_1}{f_2}\right) + (y_1 - y_2)$$

upper contribution      lower contribution

$$y_{P2} = \left(\frac{3}{2}y_1 - y_2\right)$$

If included odd no. of zones: BRIGHT  
 if included even no. of zones: DARK

~~Geometrical Optics~~

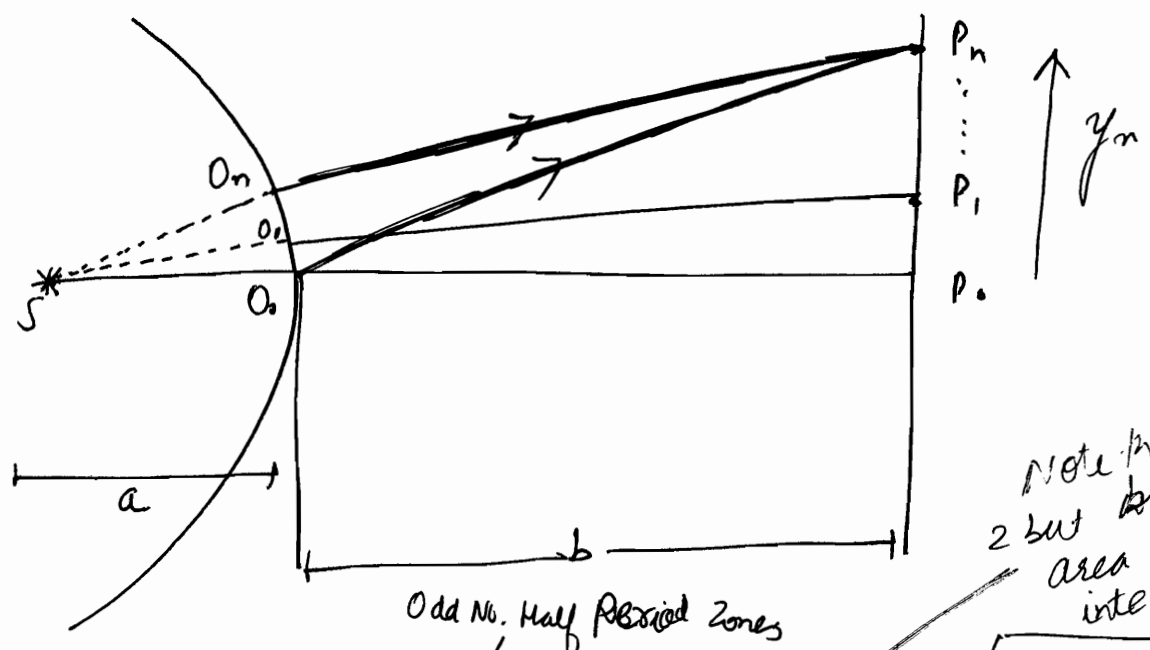

Note that ~~not~~ ~~but~~ whole area of waves interfere...

$$O_n P_n \approx O_0 P_n = (2n-1) \frac{\lambda}{2} \quad (\text{Bright})$$

$$O_n P_n \approx O_0 P_n = 2n \left(\frac{\lambda}{2}\right) \quad (\text{Dark})$$

$n$  : means absolute value of difference

→ Note that I am not interested in path difference per se but rather the number of HPZ that are getting included in this path difference

$$O_n P_n = \sqrt{y_n^2 + b^2} = b \left( 1 + \frac{y_n^2}{2b^2} \right) = b + \left( \frac{y_n^2}{2b} \right)$$

$$\begin{aligned} O_n P_n = S P_n - a &= \sqrt{(a+b)^2 + y_n^2} - a \\ &= (a+b) \left( 1 + \frac{y_n^2}{2(a+b)^2} \right) - a \\ &= (a+b) + \frac{y_n^2}{2(a+b)} - a \\ &= b + \frac{y_n^2}{2(a+b)} \end{aligned}$$

$$O_n P_n - O_n P_n = \frac{y_n^2}{2b} - \frac{y_n^2}{2(a+b)} = \frac{y_n^2}{2} \left[ \frac{1}{b} - \frac{1}{a+b} \right]$$

$$\Delta = \frac{a y_n^2}{2b} \frac{1}{(a+b)} = \frac{a}{2b(a+b)} y_n^2$$

Bright

When  $\Delta = (2n-1) \frac{\lambda}{2}$  :  $n^{\text{th}}$  bright

$$\Rightarrow \frac{a y_n^2}{b(a+b)} = (2n-1) \lambda$$

$$\Rightarrow y_n = \sqrt{\underbrace{\frac{b(a+b)\lambda}{a}}_k} \sqrt{2n-1}$$

$$\Rightarrow y_n = k \sqrt{2n-1} \quad : \text{bright}$$



$$\begin{aligned}
 y_1 &= k\sqrt{k \cdot 1 - 1} = k \\
 y_2 &= k\sqrt{2 \cdot 2 - 1} = \sqrt{3}k \\
 y_3 &= \sqrt{5}k
 \end{aligned}
 \left. \vphantom{\begin{aligned} y_1 \\ y_2 \\ y_3 \end{aligned}} \right\} \text{bright}$$

We can see, non-uniform distance....

**Dark**

$$\Delta = 2n \left( \frac{\lambda}{2} \right)$$

$$\Rightarrow \frac{a}{2b(a+b)} y_n^2 = n\lambda$$

$$\Rightarrow (y_n)_{\text{dark}} = \sqrt{\frac{2b(a+b)\lambda}{a}} \sqrt{n} = k\sqrt{2n}$$

$$\begin{aligned}
 y_0 &= 0 \\
 y_1 &= \sqrt{2}k \\
 y_2 &= \sqrt{4}k = 2k \\
 y_3 &= \sqrt{6}k
 \end{aligned}
 \left. \vphantom{\begin{aligned} y_0 \\ y_1 \\ y_2 \\ y_3 \end{aligned}} \right\} \text{dark}$$

Geometrically Shadow Region:

$$\checkmark y_{P_1} = y_2 - y_3 + y_4 - \dots$$

$$\checkmark y_{P_2} = y_3 - y_4 + y_5 - \dots$$

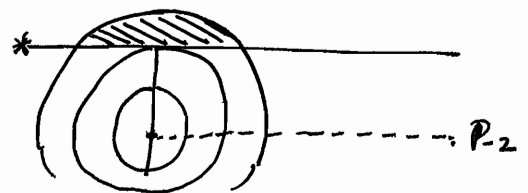
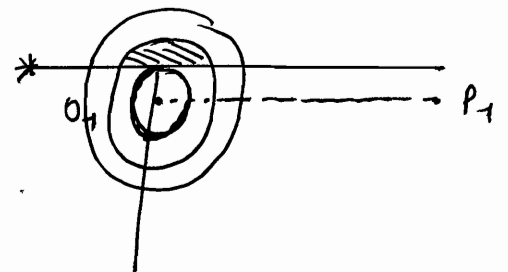

Continuously decreasing intensity

★ Entire Analysis of Fresnel diffraction is based upon Huygens - Fresnel Principle according to which:  
Each point on a wavefront is a source of secondary disturbance and the secondary wavelets emanating from different points mutually interfere.

★ We consider the incidence of a plane wave on a circular hole of diameter  $d$ .

Spreading due to diffraction is given as

$$\theta \approx \left(\frac{\lambda}{d}\right)$$

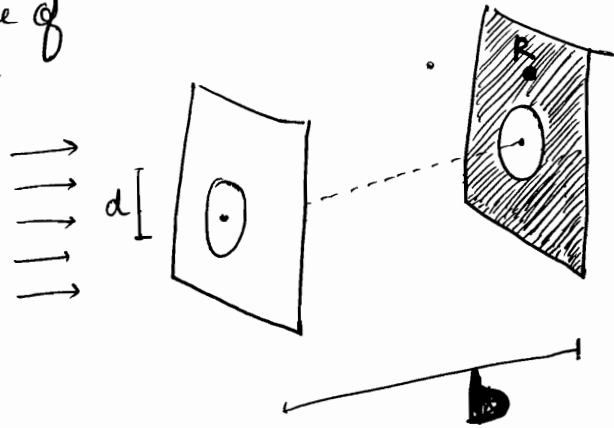

When  $d \gg \lambda$ , intensity at point R will be negligible, on the other hand if  $d \ll \lambda$ , there will almost be uniform spreading out of the beam resulting in an (almost) uniform illumination of the screen. Note that in Young's double slit experiment, point pin holes are used,  $d \ll \lambda$  is used.

When  $d \gg \lambda$ , the secondary wavelets emanating from different points of circular aperture, beautifully interfere to produce (almost) zero intensity in the geometrical shadow and large intensity in the circular region.

### Fresnel Half Period Zones

★ Let us consider a plane wavefront propagating in z direction and a point P on screen when intensity is to be found out. With P as centre and b as  $\perp$  distance between P and wavefront draw spheres of radius  $(b + \frac{n\lambda}{2})$ . These spheres will be intersected wavefront as circles of radius  $r_n$  such that

$$r_n = \sqrt{\left(b + \frac{n\lambda}{2}\right)^2 - b^2} \approx \sqrt{(2b)\left(\frac{n\lambda}{2}\right)} = \sqrt{n\lambda b}$$

The annular region between  $n^{\text{th}}$  circle and  $(n-1)^{\text{th}}$  circle is known as Half Period Zone ( $n^{\text{th}}$ ).

$$A_n = \pi R_n^2 - \pi R_{n-1}^2 = \pi [\lambda b^n] - \pi [\lambda b^{(n-1)}] = \pi \lambda b$$

Thus areas of all half period zones are approximately equal.

Now the resultant disturbance produced by the  $n^{\text{th}}$  zone will be  $\pi$  out of phase with disturbance produced by  $(n-1)^{\text{th}}$  or  $(n+1)^{\text{th}}$  zone. For infinitesimal area surround a point  $Q_n$  in the  $n^{\text{th}}$  HPZ, there is a corresponding infinitesimal area surrounding the point  $Q_{n-1}$  in  $(n-1)^{\text{th}}$  HPZ st.

$Q_n P - Q_{n-1} P = \frac{\lambda}{2}$ , which corresponds to a phase difference of  $\pi$ . Since areas are approximately equal, one can have a one-to-one correspondence between points in various zones.

The resultant amplitude at the point P can be written as,

$$u(P) = u_1 - u_2 + u_3 - u_4 + \dots$$

Where  $u_n$  represents the net amplitude produced by the secondary wavelets emanating from the  $n^{\text{th}}$  zone.

Amplitude,  $u(n)$ , produced by a particular zone is proportional to area of the zone, obliquity factor  $(1 + \cos \theta)$  and inversely proportional to the distance of the zone from the point P. Note that  $\theta$  is the angle that the normal to the zone makes with the line QP

The major reason for monotonic decrease in the amplitude of  $u_n$  is the obliquity factor.

$$u_1 > u_2 > u_3 \dots$$

Now, we get

$$u(P) = \begin{cases} \frac{u_1}{2} + \frac{u_n}{2} & n : \text{odd} \\ \frac{u_1}{2} - \frac{u_n}{2} & n : \text{even} \end{cases}$$

But  $u_n \ll u_1$  for large  $n$ .

$$\Rightarrow u(P) \approx \left(\frac{u_1}{2}\right)$$

ie. Resultant amplitude produced by the entire wavefront is only half of the amplitude produced by 1<sup>st</sup> HPZ.

### Fresnel Analysis of diffraction from circular Aperture

As the radius  $a$  ( $= \frac{d}{2}$ ) of the aperture increases from zero onwards, intensity at point P will also increase till the circular aperture contains the 1<sup>st</sup> h.p.z. i.e.  $a = \sqrt{\lambda b}$

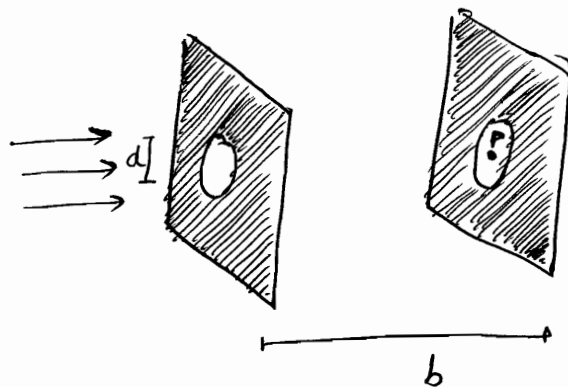

Resultant amplitude of P will be  $u_1$  which is twice the value of amplitude for unobstructed wavefront. Intensity would therefore be  $4I_0$  where  $I_0$  represents intensity at point P due to unobstructed wavefront.

If we further increase  $a$ , then  $u(P)$  drop and  $a \approx \sqrt{2\lambda b}$ , amplitude will be  $(u_1 - u_2) \approx 0$ . Thus by increasing the hole diameter, intensity at point P decreases almost to zero. Such results are valid for sound waves also.

In general, if  $a = \sqrt{(2n+1)\lambda b}$  i.e. aperture contains odd number of HPZs, intensity will be maximum.

On the other hand, if  $a = \sqrt{(2n) \lambda b}$  i.e. aperture contains even number of HPZs, intensity will be minimum.

For fixed  $a$ ,

$$b = \frac{a^2}{(2n-1)\lambda} \quad \text{maxima}$$

$$b = \frac{a^2}{2n\lambda} \quad \text{minima}$$

} intensity along the axis.

The analysis of intensity on off-axis points can be approximately calculated by HPZs but such a calculation is fairly cumbersome. (But we do Fraunhofer for them)

Diffraction due to Opaque Disk - Poisson Spot

If the circular disk obstructs the first  $p$  half period zones, then the amplitude at point P will be

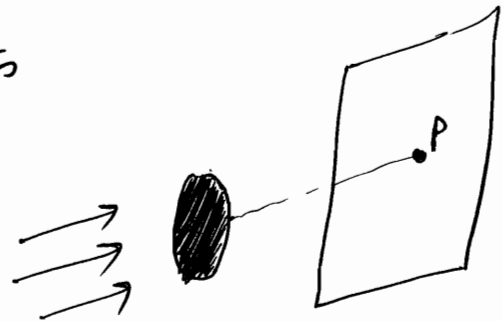

$$u(P) = u_{p+1} - u_{p+2} + u_{p+3} - \dots$$

$$\approx \frac{u_{p+1}}{2}$$

Therefore we should always obtain a bright spot on the axis behind an opaque circular disk. This ~~bright~~ spot is called POISSON SPOT.

## Zone Plate

Zone Plate is an application of Fresnel Diffraction via Half Period Zones. It consists of large number of concentric circles whose radii are proportional to square root of natural numbers and the alternate annular regions of which are blackened.

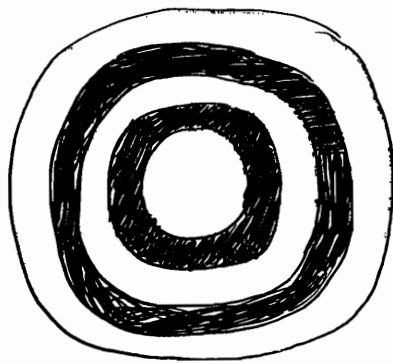

Let the radius of the circles be  $\sqrt{1}k, \sqrt{2}k, \sqrt{3}k, \sqrt{4}k, \dots$   
 where  $k$  is a constant having dimension of length.

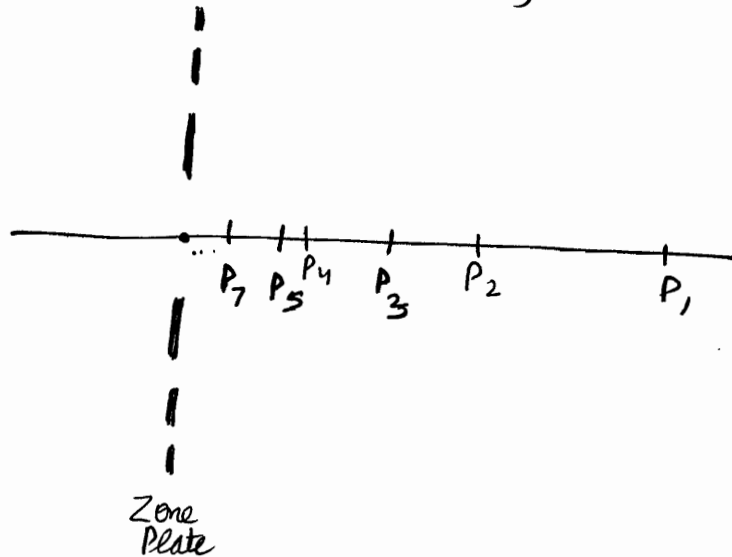

Consider a point  $P_1$  at distance  $(k^2/\lambda)$  and a plane wave incident upon the zone plate. For such a point  $P_1$ , the blackened rings correspond to 2<sup>nd</sup>, 4<sup>th</sup>, 6<sup>th</sup>... HPZ. Thus even zones are obstructed.

$$u(P_1) = u_1 + u_3 + u_5 + \dots$$

producing an intense maxima.

Note Consider point  $P_3$  at distance  $(k^2/3\lambda)$ , for such a point, 1<sup>st</sup> white ~~zone~~ will entail, 1<sup>st</sup>, 2<sup>nd</sup> and 3<sup>rd</sup> ~~HPZ~~ HPZ. 1<sup>st</sup> blackened region will have 4<sup>th</sup>, 5<sup>th</sup>, 6<sup>th</sup> HPZs are so on

$$\Rightarrow u(P_3) = (u_1 - u_2 + u_3) + (u_4 - u_5 + u_6) + \dots$$

Between  $P_1$  and  $P_3$  will lie a point  $P_2$  such that, 1<sup>st</sup> white ~~zone~~ will 1<sup>st</sup> entail 1<sup>st</sup>, 2<sup>nd</sup> HPZ .....

$$\Rightarrow u(P_2) = (u_1 - u_2) + (u_5 - u_6) + \dots$$

$P_2$  will correspond to a minima.

Therefore, if a plane wave is incident normally on a zone plate, then the corresponding focal points are at distances

$$\frac{k^2}{\lambda}, \frac{k^2}{3\lambda}, \frac{k^2}{5\lambda}, \dots, \frac{k^2}{(2p-1)\lambda} \quad (p=1, 2, 3, \dots)$$

from the zone plate.

### Image formation in Zone Plate

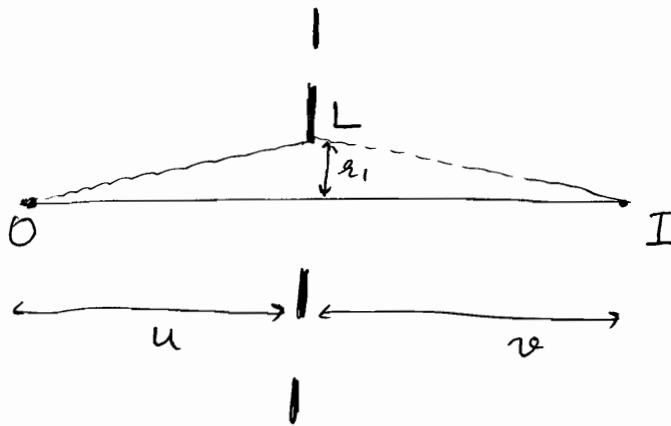

Zone plate can also be used for imaging points on the axis. A bright image of source O will be formed at I, if the first white zone of plate corresponds to 1<sup>st</sup> HPZ (or 3<sup>rd</sup> HPZs, 5 HPZs, 7 HPZs etc.)

$$\Rightarrow OL + LI - OI = \lambda/2$$

$$\Rightarrow \sqrt{u^2 + r_1^2} + \sqrt{v^2 + r_1^2} - (u+v) = \frac{\lambda}{2}$$

$$\Rightarrow \frac{r_1^2}{2u} + \frac{r_1^2}{2v} = \frac{\lambda}{2}$$

$$\Rightarrow \frac{1}{u} + \frac{1}{v} = \left( \frac{\lambda}{r_1^2} \right)$$

(remember, 1<sup>st</sup> focus point P<sub>1</sub> was having  $f = \frac{r_1^2}{\lambda}$ )

$$\Rightarrow \boxed{\frac{1}{u} + \frac{1}{v} = \frac{1}{f_1}}$$

$$\underline{\underline{f_1 = \frac{r_1^2}{\lambda}}}$$

Also another image will be formed at  $I_3$ , s.t.

$$\sqrt{u^2 + r_1^2} + \sqrt{u^2 + r_2^2} - (u+v) = \left(\frac{3\lambda}{2}\right) \quad [1^{st} \text{ 3 HPZs}]$$

$$\Rightarrow \frac{1}{2} \left(\frac{r_1^2}{u}\right) + \frac{1}{2} \left(\frac{r_2^2}{v}\right) = \frac{3\lambda}{2}$$

$$\Rightarrow \frac{1}{u} + \frac{1}{v} = \frac{1}{f_3} \quad \underline{\underline{f_3 = \frac{r_1^2}{3\lambda}}}$$

## Diffraction due to straight edge

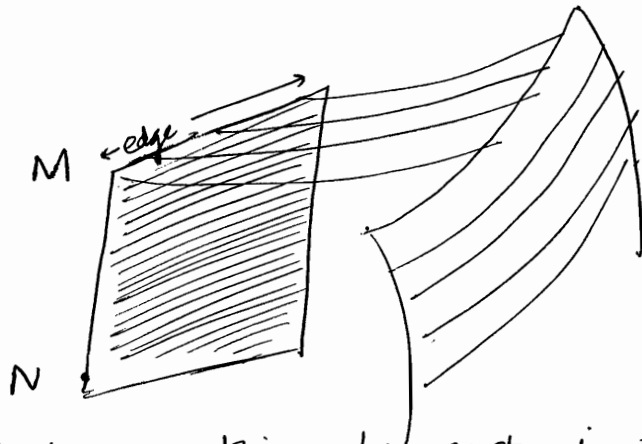

The most important thing to note is that the diffraction due to straight edge will give rise to a cylindrical wavefront

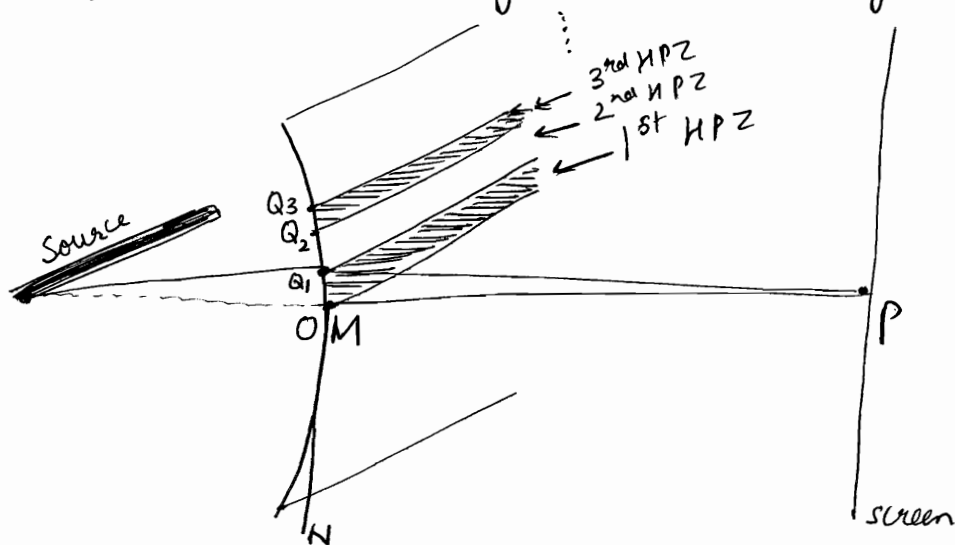

because the source is applied parallel to the length of the edge. From the geometry of the arrangement it's obvious that on screen there will be no intensity variation along the direction of the straight edge. Thus fringes will be straight lines parallel to



the edge

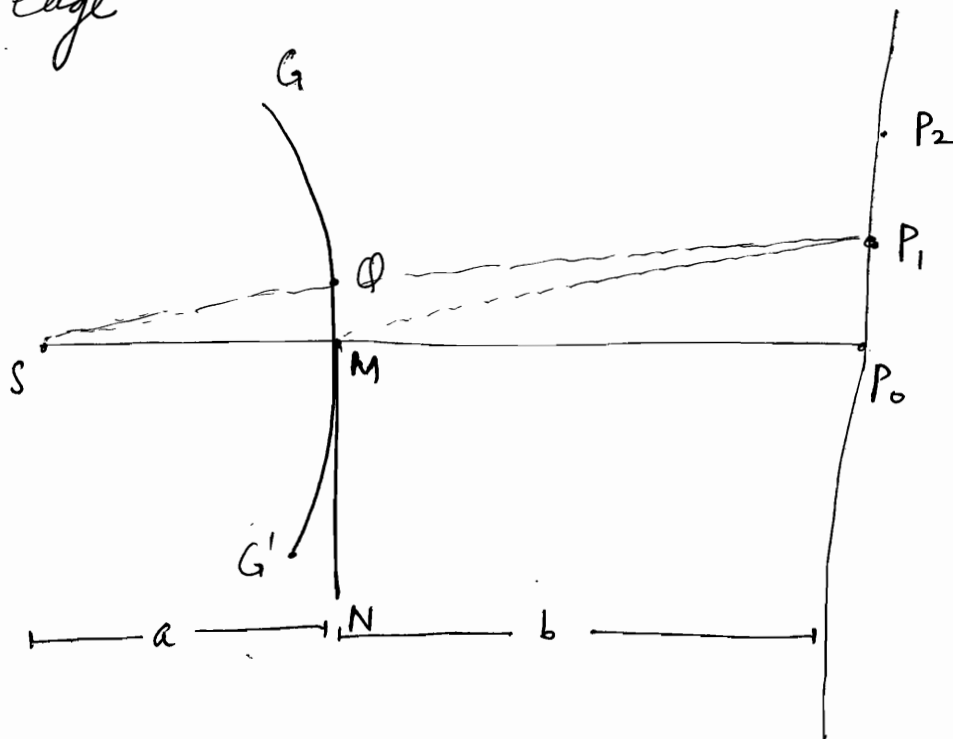

Let \$GQMG'\$ represent a section of the wavefront

- ① Corresponding to edge of geometrical shadow (point \$P\_0\$), half of the wavefront is obstructed by edge, hence amplitude will be

$$u(P_0) = \frac{u_0}{2}$$

Where \$u\_0\$ represents amplitude produced by unobstructed wave (\$u\_0 \approx \frac{u\_1}{2}\$)

$$\Rightarrow I(P_0) = \left(\frac{I_0}{4}\right)$$

- ② Let consider point \$P\_1\$ that satisfies,

$$SM + MP_1 - SQP_1 = \left(\frac{\lambda}{2}\right)$$

$$(PM - PQ)$$

\$\therefore\$ only the first half period zone of the lower part of wavefront contributes

$$\Rightarrow u(P_1) = \frac{u_1}{2} + \frac{u_0}{2} = \frac{3u_0}{2}$$

\$\uparrow\$ lower half contribution due to 1<sup>st</sup> HPZ - 1/2 strip

\$\uparrow\$ upper half

$$\Rightarrow I(P_1) = \left(\frac{9I_0}{4}\right)$$

③ Consider point  $P_2$  s.t.

$$SM + MP_2 - SQP_2 = \lambda \quad \Rightarrow \text{it corresponds to minima}$$

$$\Rightarrow u(P_2) = \frac{u_0}{2} + \left[ \left( \frac{u_1}{2} \right) - \left( \frac{u_2}{2} \right) \right]$$

$\uparrow$  upper half                       $\uparrow$  lower 2 HPZs

④ In general, an arbitrary point  $P$  will correspond to a maxima, if

$$SM + MP - SP = (2n-1) \frac{\lambda}{2}$$

$\Delta$  minima if  $SM + MP - SP = (2n) \frac{\lambda}{2}$  (binomial approximation)

Also  $SM + MP - SP \Rightarrow$

$$MP = \sqrt{b^2 + y_n^2} = b + \frac{y_n^2}{2b}$$

$$SP = \sqrt{(a+b)^2 + y_n^2} = a+b + \frac{y_n^2}{2(a+b)}$$

$$SM = a$$

$$\Rightarrow \Delta = SM + MP - SP$$

$$= \frac{y_n^2}{2b} - \frac{y_n^2}{2(a+b)} = \frac{a}{2b(a+b)} y_n^2$$

Hence Maxima  $y_n^2 = \frac{2b(a+b)}{a} \frac{\lambda}{2} (2n-1)$

$$y_n = \sqrt{(2n-1)} \left[ \frac{b(a+b)\lambda}{a} \right]^{1/2}$$

Minima  $y_n = \sqrt{2n} \left[ \frac{b(a+b)\lambda}{a} \right]^{1/2}$

# OPTICS (15)

21/12/11

## Zone Plate (s)

Zone Plate is a specially designed diffracting screen, which acts as a converging lens of multiple foci.

Draw circles with (radius)<sub>n</sub>  $\propto \sqrt{n}$  where  $n \in \mathbb{N}$

Paint alternate dark. Take the photograph

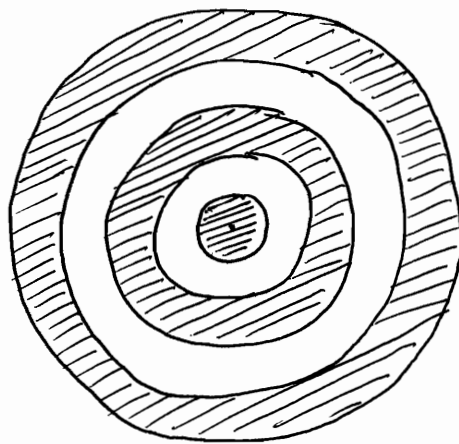

Negative Zone Plate

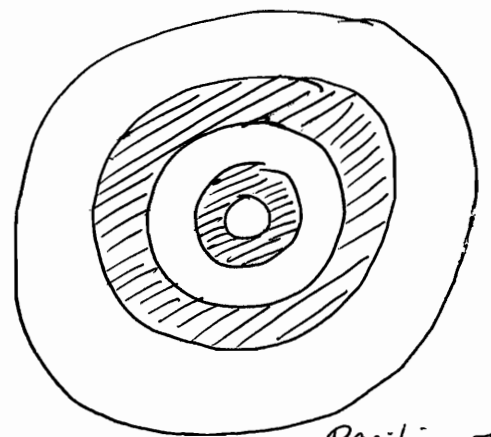

Positive Zone Plate

→ Annulara regions b/w circles become HPZs.

$$r_1 = r_0$$

$$r_2 = r_0 \sqrt{2}$$

$$r_3 = r_0 \sqrt{3}$$

⋮

$$A_n = \pi r_0^2 (n) - \pi r_0^2 (n-1)$$

$$\underline{A_n = \pi r_0^2 = \text{const.}}$$

## Sectional view of Zone Plate

$$OMI \sim ONI = \left(\frac{n\lambda}{2}\right)$$

$$(OM + MI) - (u+v) = \frac{n\lambda}{2}$$

$$\sqrt{u^2 + r_n^2} + \sqrt{v^2 + r_n^2} - (u+v) = n\lambda/2$$

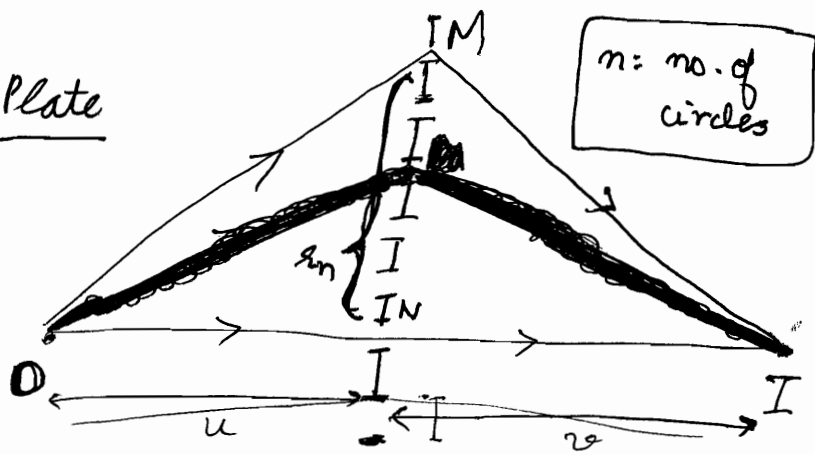

Note that no alternate maxima or minima  $\Rightarrow$  act as converging lens.

I = either   $(y_1 + y_3 + y_5 + \dots)^2 \rightarrow \oplus$ ve Zone Plate  
 or  $(y_2 + y_4 + y_6 + \dots)^2 \rightarrow \ominus$ ve Zone Plate

$$\Rightarrow u + \frac{r_n^2}{2u} + v + \frac{r_n^2}{2v} - u - v = \frac{n\lambda}{2}$$

$$\Rightarrow \left(\frac{r_n^2}{2}\right) \left[\frac{1}{u} + \frac{1}{v}\right] = \frac{n\lambda}{2}$$

$$\Rightarrow \boxed{\frac{1}{u} + \frac{1}{v} = \left(\frac{n\lambda}{r_n^2}\right)}$$

Note that

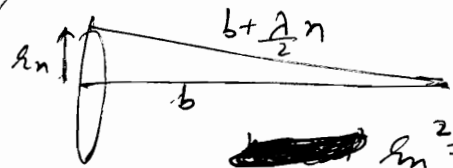

~~$r_n^2 = n\lambda b$~~   
 $\Rightarrow b = \left(\frac{r_n^2}{n\lambda}\right)$   
 This was for plane wave....  
 Now for generic v and u

If  $u \rightarrow \infty \Rightarrow v = f$

$$\Rightarrow \frac{1}{f} = \frac{n\lambda}{r_n^2} \Rightarrow$$

$$\boxed{f = \frac{r_n^2}{n\lambda}}$$

Main focus

For brightest image:  $f_1 = \left(\frac{r_n^2}{n\lambda}\right)$

$$r_n = \sqrt{n\lambda d}$$

$$\checkmark f = \frac{r_n^2}{n\lambda} = \underline{\underline{d}}$$

Since f dependent on  $\lambda$   
 $\Rightarrow$  it will suffer from chromatic aberrations

But here  $f \propto \frac{1}{\lambda}$

$\Rightarrow f_B > f_R$  for zone plate

At Inge, Intensity =  $(y_1 + y_3 + y_5 + \dots)^2$

# Multiple Focus

$$f = \frac{2n^2}{n\lambda}$$

There are other foci such that

$$f_p = \frac{2n^2}{n\lambda(2p-1)} = \left( \frac{f_1}{2p-1} \right)$$

∴ even if we add odd multiples, we get positive value...

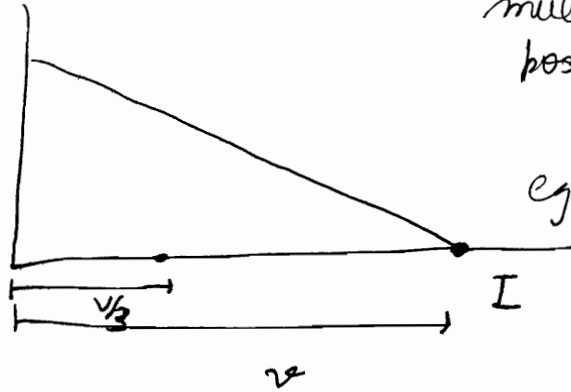

eg.  $u(f/3)$

$$= (u_1 + u_2 + u_3) + (u_7 - u_8 + u_9)$$

If Image I is formed at distance  $v$ .  
@  $d = (v/3)$

$$+ (u_{13} - u_{14} + u_{15})$$

$$y_{3v} = (\pi v \lambda)$$

$$y_{v/3} = \left( \frac{\pi v \lambda}{3} \right)$$

✓ Note that this is  $2\lambda z$   
OMI ~ ONI =  $(2p-1)\frac{n\lambda}{2}$   
for positive interference

⇒ 1 HPZ is divided into 3 HPZs

$$\frac{v}{3}, \frac{v}{5}, \frac{v}{7}, \dots, \frac{v}{(2p-1)}$$

$p=1, 2, 3, \dots$

@  $d = \frac{v}{(2p-1)}$  : 1 HPZ is divided into  $(2p-1)$  HPZs

$$\Rightarrow \underbrace{s_1, s_2, s_3}_{y_1}, \quad \underbrace{s_7, s_8, s_9}_{y_3}, \quad \underbrace{s_{13}, s_{14}, s_{15}}_{y_5}$$

$$\begin{aligned}
 y_{I_3} &= (s_1 - s_2 + s_3) + (s_7 - s_8 + s_9) + (s_{13} - s_{14} + s_{15}) \\
 &= \left[ \frac{s_1}{2} + \left( \frac{s_1}{2} - s_2 + \frac{s_3}{2} \right) + \frac{s_3}{2} \right] + \dots \\
 &= \frac{(s_1 + s_3)}{2} + \dots = \left( \frac{u_1 + u_3}{2} \right) + \left( \frac{u_7 + u_9}{2} \right) \\
 s_1 \approx s_3 &\approx \left( \frac{y_1}{3} \right) \approx \frac{u_1 + u_3 + u_5}{3} + \frac{u_7 + u_9 + u_{11}}{3}
 \end{aligned}$$

$$\begin{aligned}
 &= \frac{u_1 + u_2 + u_5 + u_{11} \dots}{3} \\
 &= \frac{y_1}{3} + \frac{y_3}{3} + \frac{y_5}{3} + \dots = \left[ \frac{I(f)}{3} \right]
 \end{aligned}$$

$$= \frac{1}{3} (y_1 + y_3 + y_5 + \dots)$$

$$= \left( \frac{1}{3} \right) y_I$$

$$I(3f) = \frac{I(f)}{9}$$

→ similarly we write

$$\left( \frac{u_1}{2} + \frac{u_5}{2} \right) \approx \left( \frac{u_1 + u_3 + u_5 + u_7 + u_9}{5} \right)$$

$$\Rightarrow I(5f) = \frac{I(f)}{25}$$

$$I_{(2p-1)} = \frac{I_0}{(2p-1)^2}$$

$$f_p = \frac{r_n^2}{n\lambda (2p-1)}$$

$$\text{i.e. } \frac{1}{u} + \frac{1}{v} = \frac{n\lambda (2p-1)}{r_n^2}$$

$n$ : no. of zones exposed  
Brightest image for  $p=1$

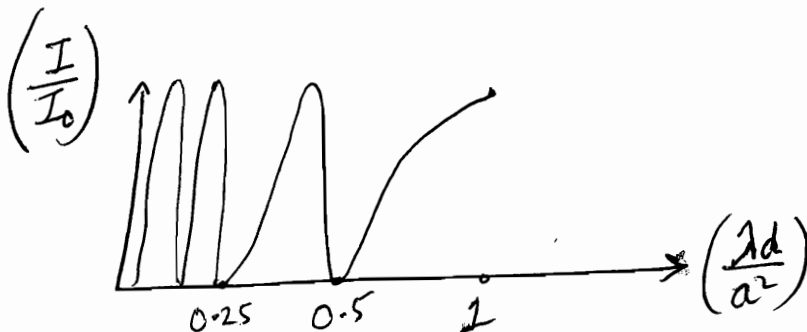

$$d = \frac{a^2}{\lambda(2p-1)}$$

# POLARISATION

## AND MODERN OPTICS

- Methods of Polarization
- Nicol Prism Polarizer
- Half-wave Plates (HWP)
- Nicol Prism Analyzer
- Optical rotation

Light is an EM wave.

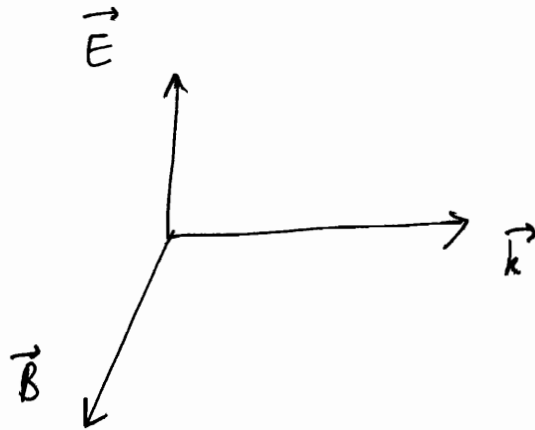

$(\vec{E}, \vec{B}, \vec{k})$ : right handed triad

$\vec{B}$  is negligible as  $B = \left(\frac{E}{c}\right)$

$\Rightarrow$  all optical phenomenon are manifestation of  $\vec{E}$  vector mainly

**WAVE PROPAGATION is  $\perp$  to  $\vec{E}$**   $\Leftarrow$  NO DOUBTING.

Plane of Polarization: Plane in which  $\vec{E}$  lies.

if  $\vec{k}$  along z axis  $\Rightarrow \vec{E}$  ~~along~~ <sup>in</sup> xy ~~is~~ plane

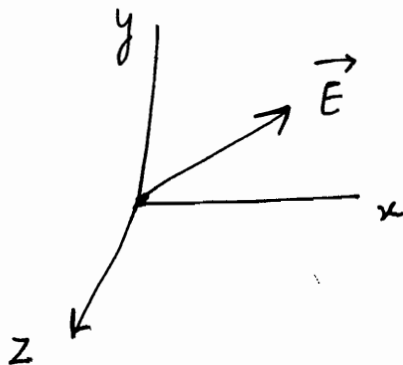

$\vec{E}$  is linearly polarized:  
 $E_x$  and  $E_y$  are having SHM

If  $\vec{E}$  is random in xy plane  $\Rightarrow$  Unpolarized light

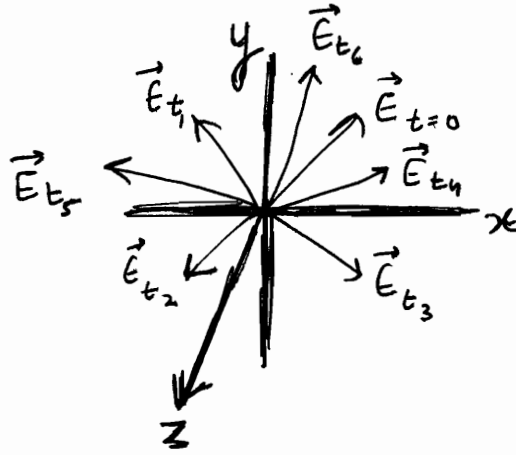

← note that all  $\vec{E}$  in xy plane

✓ If tip of  $\vec{E}$  traces circle  $\Rightarrow$  Circular Polarized light

✓ If tip of  $\vec{E}$  traces ellipse  $\Rightarrow$  Elliptically Polarized light.

### 6 methods to produce Polarization [Linear]

Reflection, Refraction, Scattering, Selective Absorption, Double Refraction, Optical Activity !!

#### Reflection ✓

$$\theta + r = 90^\circ$$

$$\frac{\sin i}{\sin r} = \frac{n_2}{n_1}$$

$$\frac{\sin i}{\sin (90-i)} = \frac{n_2}{n_1}$$

$$\Rightarrow \tan i = \left( \frac{n_2}{n_1} \right)$$

$$\Rightarrow i = \tan^{-1} \left( \frac{n_2}{n_1} \right)$$

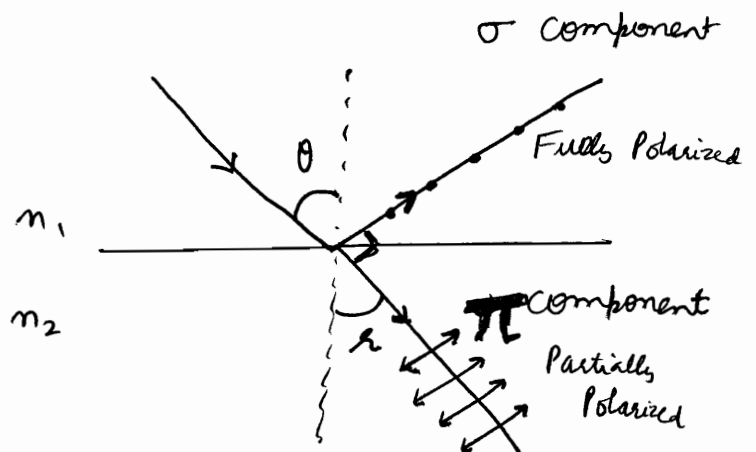

$\theta$ : Brewster Angle

~~Method is not preferred~~

(Method is not preferred as intensity of light is less as much is wasted in refraction)



## 2) Polarization by Reflection ✓

Using Pile of refracting Plates.

Used in Biot's Polariscope

If we use  $m$  plates, each of index  $\mu$ , then degree of Polarization is defined as

$$P = \left( \frac{I_{\pi} - I_{\sigma}}{I_{\pi} + I_{\sigma}} \right) = \frac{m}{m + \left( \frac{2\mu}{1-\mu^2} \right)^2}$$

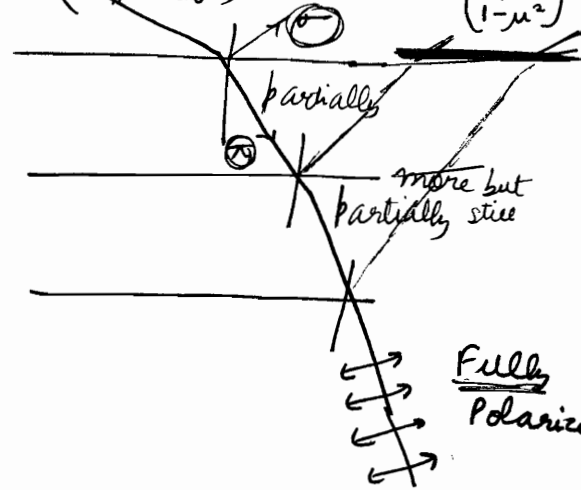

★ Note that in the reflection method, the transmitted wave is partially polarized and if ~~we~~ uses a large number of reflecting surfaces, one would obtain an almost plane polarized transmitted beam.

## 3) Scattering ✓

(करी इतना ही !!)

## 4) Selective Absorption

Certain crystals selectively absorb the light along particular direction  $\therefore$  Polaroid

~~Component wise~~

Component wise

$$E = E_0 \cos \theta$$

$$\Rightarrow I = I_0 \cos^2 \theta$$

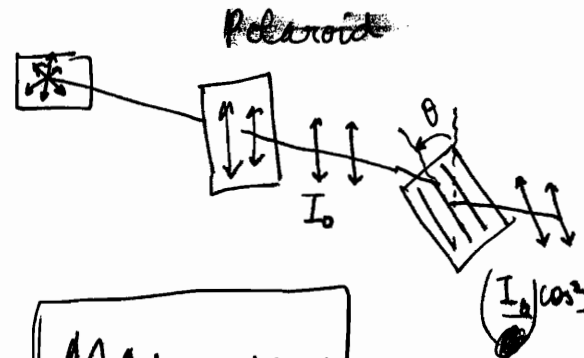

**MALUS LAW**

For incident unpolarized light, Taking average value

$$I = I_0 \langle \cos^2 \theta \rangle = \underline{\underline{\left( \frac{I_0}{2} \right)}}$$

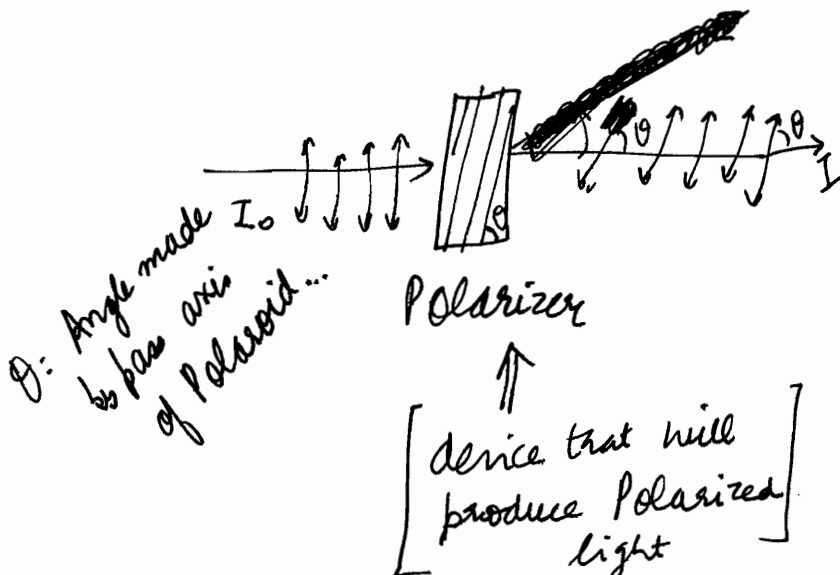

## 5) Double Refraction or Birefringence

It can produce circularly polarized light,  
elliptically polarized light

and of course linearly polarized light

## (6) Optical Activity

★ Plane Polarized: Confined to a plane  
Linearly Polarized: moving along a straight line

★ Polarization is solely a property of transverse waves

### ★ Theory of Double Refraction

When an unpolarized beam enters an anisotropic crystal, it splits up into two beams, each of them being characterized by a certain state of polarization. If by some method, we could eliminate one beam, we would get a linearly polarized beam.

2 common ways to eliminate a beam:

#### (a) Selective Absorption

This property is called DICHROISM. A crystal called Tourmaline has different coefficients of absorption for two linearly polarized beams. Correspondingly one gets absorbed and other passes without much attenuation.

#### (b) Total Internal Reflection

$\mu_o$  and  $\mu_e$  are different. One can sandwich a layer of a material whose  $\mu$  lies between the two. Thus one of the beams is totally internally reflected & eliminated. eg. Canada Balsam layer in Calcite Crystal. Such a structure is called NICOLE PRISM.

# OPTICS (16)

22/12/2011

## Polarization by double refraction

double refraction produces 2 images for an image. Only some crystals have property of double refraction.

Out of the 2 refracted rays, 1 ray obeys the law of refraction (Snell's law). Its called Ordinary Ray. 2<sup>nd</sup> Ray does not obey Snell's law. Its called Extra Ordinary Ray.

2<sup>st</sup> ray is polarized parallel to plane ... ⊕ Ray ⊖ Ray  
 1<sup>st</sup> ray is polarized perpendicular to plane ... ⊙ Ray

Their velocities are different ... i.e.  $\mu_1 \neq \mu_2$

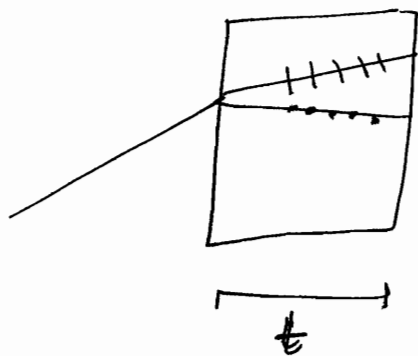

(Quartz)  
 If Ordinary Ray travels ( $v_o > v_e$ ) faster: POSITIVE CRYSTAL

If Extra Ordinary Ray travel ( $v_e > v_o$ ) faster: NEGATIVE CRYSTAL (Calcite)

अगर बाधा तेज दंडेगा, तो धुरी होगी... hence ⊕ve from frame of man

$$\Delta = (\mu_o - \mu_e) t$$

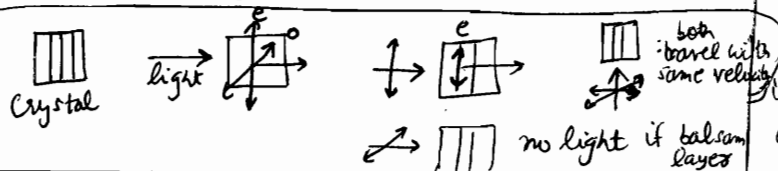

Note that there are 2 sets of directions  
 1) directions of polarization  
 2) directions of velocity along with different components have different magnitude of velocities.

Usually direction of  $\vec{v}$  is along  $\hat{k}$  and direction of polarization are in x-y plane

In every crystal, at least there is 1 direction along which both rays O and E travel with same velocity.

This direction is called **OPTICAL AXIS OF CRYSTAL**.

Any direction  $\parallel$  to optic axis is also optic axis.

Along this direction, light does not exhibit birefringence (both o and e travelling have equal velocity).

Uniaxial : 1 Optical axis

\* For any ray, not  $\parallel$  to optical axis ~~not~~

eg. Quartz :  $\oplus$ ve uniaxial

Calcite :  $\ominus$ ve uniaxial

~~not~~ 2 rays

are observed  $\Rightarrow$  2 images are formed

According to Fresnel-Huygen Theory,

O will have spherical wavefront  
E will have Elliptical wavefront.

Also, wave should not travel  $\perp$  to optic axis, for 2 images

Same direction of light

In a plane cross section,

O will have circular wavefront  
E will have ellipse wavefront

P-22-16

Uniaxial doubly refractive Positive Crystal eg. Quartz

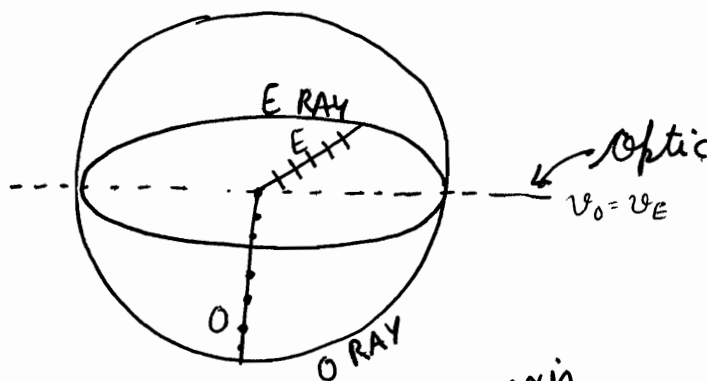

$v_o > v_e$   
 $\Rightarrow$  POSITIVE

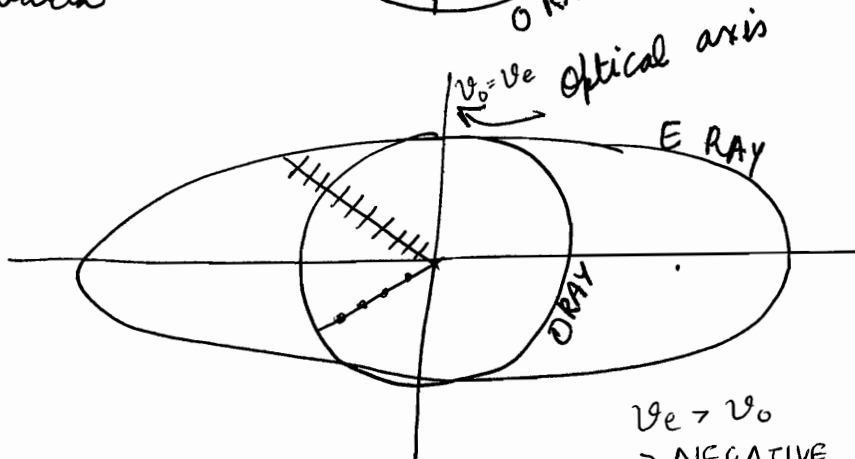

$v_e > v_o$   
 $\Rightarrow$  NEGATIVE

Uniaxial doubly refractive Negative Crystal eg. Calcite

# Production of Polarized light

We will use Nicol Prism.

Device used for producing Polarized light : Polarizer  
 Device used to detect polarised light : Analyzer.

## Polarizer

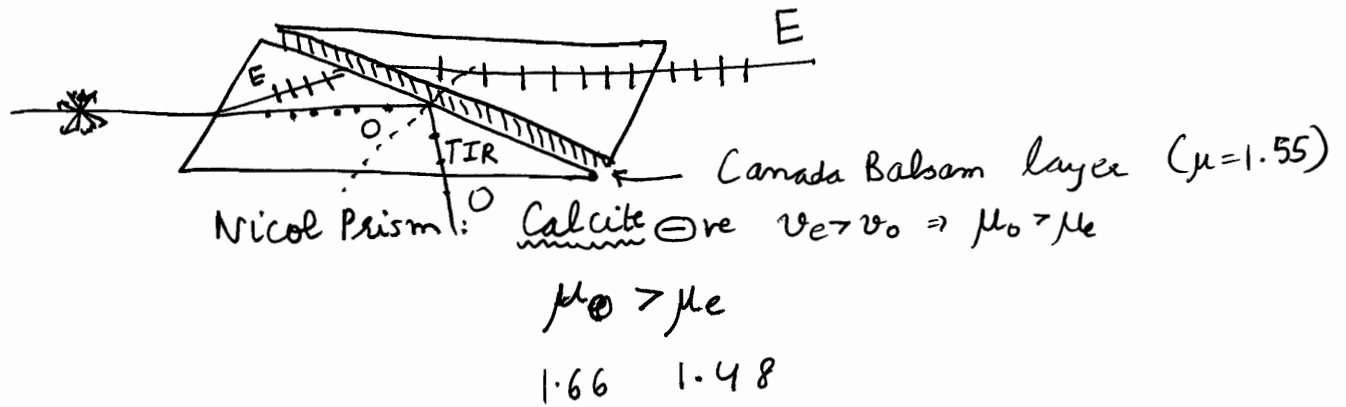

Emerging Ray is only E ray : linearly polarized light.  
vibrations parallel to plane.

## Analyzer

Now let us take rotating Nicol Prism

No change in Intensity if unpolarized light is passed through Nicol Prism.

In case of linearly polarized light, it will show 0 intensity, as the crystal blocks light along 1 direction, in a single rotation

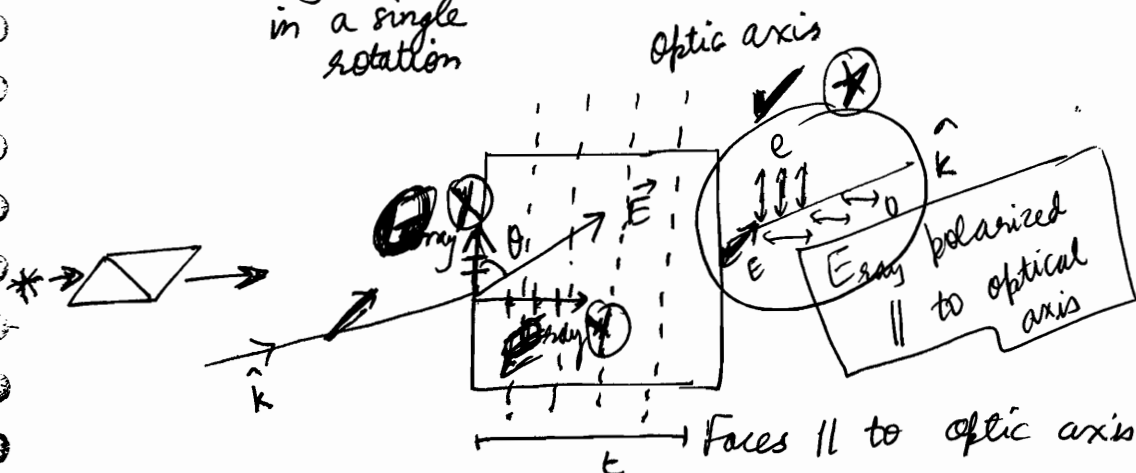

if the direction of propagation is along z

$$E_x = E \sin \theta e^{i(kz - \omega t)} \quad \text{O Ray}$$

$$E_y = E \cos \theta e^{i(kz - \omega t + \phi)} \quad \text{E Ray}$$

$$\Delta = (\mu_o \sim \mu_e) t$$

$$\phi = \frac{2\pi}{\lambda} (\mu_o \sim \mu_e) t$$

\* Now its in general analysis of wave coming out of crystal

(\*) Initially taken a linearly polarized light

$$E_x = a \sin(kx - \omega t)$$

$$E_y = b \sin(kx - \omega t)$$

Superposition of these waves will come out. (\*) Now passed through a polarizer that introduces a relative phase  $\phi$  in say  $y$ .

To find locus: eliminate time

These are called Lissajous Figures.

(\*) Remember E ray is polarized parallel to optical axis. In this case  $y$ -axis

$$\begin{cases} x = a \sin(kz - \omega t) \\ y = b \sin(kz - \omega t + \phi) \end{cases}$$

$$\Rightarrow \boxed{\frac{x^2}{a^2} + \frac{y^2}{b^2} - \frac{2xy}{ab} \cos \phi = \sin^2 \phi}$$

depending on  $\phi$ , various figures will be formed....

$$\frac{y}{b} = \frac{x}{a} \cos \phi + \sqrt{1 - \frac{x^2}{a^2}} \sin \phi$$

$$\Rightarrow \frac{y^2}{b^2} + \frac{x^2}{a^2} \cos^2 \phi - \frac{2xy}{ab} \cos \phi = \left(1 - \frac{x^2}{a^2}\right) \sin^2 \phi$$

$$\Rightarrow \frac{y^2}{b^2} + \frac{x^2}{a^2} - \frac{2xy}{ab} \cos \phi = \sin^2 \phi$$

$$\frac{E_x^2}{a^2} + \frac{E_y^2}{b^2} - 2 \frac{E_x E_y}{a \cdot b} \cos \phi = \sin^2 \phi$$

Linear or Circular or Elliptical Polarized light depending upon  $t$  (thickness of crystal)

If  $\Delta = \frac{\lambda}{2}$  : Half Wave Plate

$\Delta = \frac{\lambda}{4}$  : Quarter Wave Plate

Also called retardation plates

Case 1

(note that here we are not talking about phase difference between 2  $\perp$  travelling fields but rather phase difference between 2  $\perp$  direction of polarization of same beam)

$$\phi = n\pi$$

$$\Rightarrow \Delta = \frac{\lambda}{2\pi} \cdot \phi = \left(\frac{n\lambda}{2}\right)$$

**Half Wave Plate**

Produces linearly Polarized light

$$(\mu_o - \mu_e) t = \frac{n\lambda}{2} \quad (n=1 \text{ usually})$$

$$t = \frac{n\lambda}{2(\mu_o - \mu_e)}$$

Hence if  $t = \uparrow \Rightarrow$  it becomes half wave polarizer or half wave plate. It produces linearly polarized light.

$$\frac{E_x^2}{a^2} + \frac{E_y^2}{b^2} \pm 2 \frac{E_x E_y}{ab} = 0$$

$$\Rightarrow \left( \frac{E_x}{a} \pm \frac{E_y}{b} \right)^2 = 0$$

$$\Rightarrow \boxed{E_x = \pm \frac{a}{b} E_y}$$

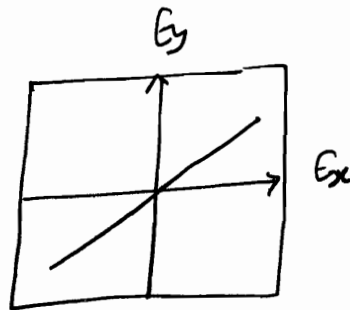

$$\boxed{2n\pi}$$

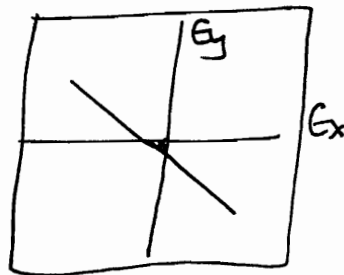

$$\boxed{n\pi}$$

Case 2

$$\phi = (2n-1) \frac{\pi}{2}$$

$$\boxed{\frac{E_x^2}{a^2} + \frac{E_y^2}{b^2} = 1 \quad : \quad \text{ellipse}}$$

$$\Delta = \frac{\lambda}{2\pi} \cdot (2n-1) \frac{\pi}{2} = \frac{(2n-1)\lambda}{4} \quad :$$

**Quarter Wave Plate**

$$(\mu_o - \mu_e) t = (2n-1) \frac{\lambda}{4}$$

$$\Rightarrow \boxed{t = \frac{(2n-1)\lambda}{4(\mu_o - \mu_e)}} \quad (n=1 \text{ usually})$$



Hence such a choice of  $t_0$  will produce Quarter Waveplate Path difference.   
 ("left" & "right" refers to the hand that is used to apply screw rule)

✓  $\frac{\pi}{2}, \frac{5\pi}{2}, \dots$

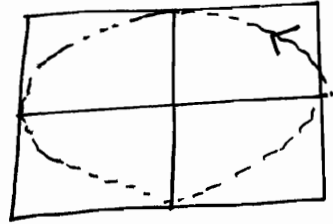

Right Elliptically Polarized light (REP)

$\frac{3\pi}{2}, \frac{7\pi}{2}, \dots$

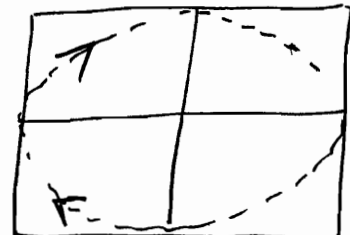

Elliptically left Polarized (LEP) light

Given equation:  $E_x = a \sin(kz - \omega t)$  and  $E_y = a \sin(kz - \omega t + \frac{\pi}{2})$   
 How to tell LCP or RCP. Put  $z=0$ , if with  $t \uparrow$ ,  $E_x$  and  $E_y$ 's variation observe. eg. this is RCP

~~scribble~~

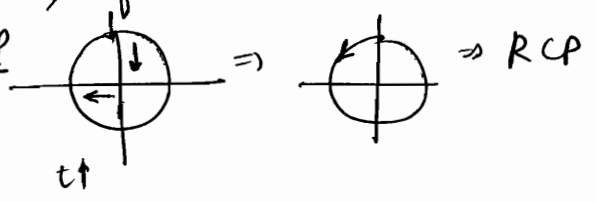

$a=b$

ie.  $\vec{E}$  was making angle of  $45^\circ$  when strike the plate.

$\Rightarrow$  Circularly Polarized light  $\rightarrow +\frac{\pi}{2} \Rightarrow$  RCP

RCP :  $\frac{\pi}{2}, \frac{5\pi}{2}, \dots$

LCP :  $\frac{3\pi}{2}, \frac{7\pi}{2}, \dots$

it depends upon if you write  $E = a \sin(kx - \omega t)$  &  $a=b$   
 $\rightarrow$  if you write  $E = a \sin(\omega t - kx)$  then  $+\frac{\pi}{2}$  will correspond to LCP

★ If Elliptically Polarized light passed through Quarter wave plate again  $\Rightarrow$  linearly Polarized light

For ellipse : take  $E_x = a \sin(\omega t - kx) \Rightarrow E_x = a \sin(\omega t - kx)$   
 $E_y = b \cos(\omega t - kx) \Rightarrow E_y = a \cos(\omega t - kx + \frac{\pi}{2})$   
 Now introduce  $\phi$  in  $E_y \Rightarrow \frac{E_x^2}{a^2} + \frac{E_y^2}{b^2} + \frac{2E_x E_y}{ab} \sin \phi = \cos^2$

# Detection

Given beam of light

Given beam of light

Rotating  
~~and~~  
Polaroid

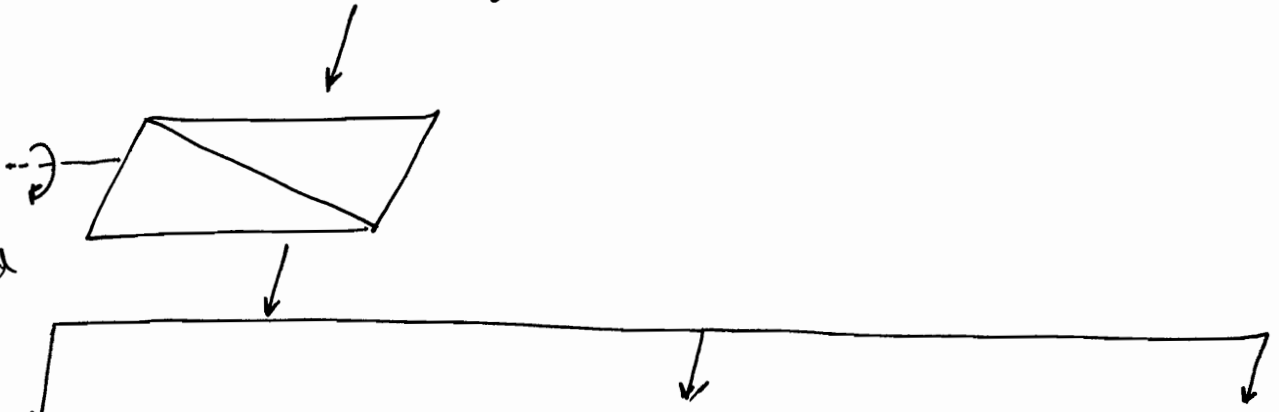

Intensity varies  
& twice becomes 0

NO intensity variation

Intensity varies but never becomes 0

Linearly Polarized

Unpolarized  
or  
Circular Polarized

Mixture  
(Partially Plane Polarized)  
or  
Elliptical Polarized

Hence



behave as Analyzers

Quarter Wave Plate

QWP

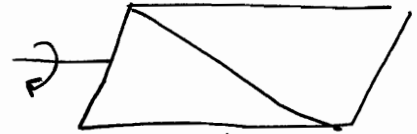
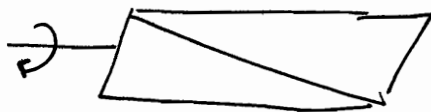

Intensity twice becomes zero

NO variation

Intensity twice 0

No variation

Circularly

Unpolarized

Elliptical

Mixture

# OPTICAL ACTIVITY

Phenomenon exhibited by Crystals or Solutions.

eg. Quartz Crystal eg. Sugarcane Solution

Rotation of Plane of Polarization of incident Plane Polarized light is called Optical Activity.

Angle by rotated is called : Angle of Optical Rotation

Solutions / Crystals are called : Optically Active

$\theta^{\circ} =$  Angle of Optical Rotation

$\frac{\theta^{\circ}}{d \cdot c} =$

$$\frac{\pi}{\lambda} (\mu_R - \mu_L) t$$

↑  
right rotation  
 $\mu$

↑  
left rotation  
 $\mu$

(half of the phase difference)

$\mu_R$  is less  $\Rightarrow$   $v_R$  is more  $\Rightarrow$  Right Handed  
Optically Active Medium  
or

Dextro Rotating Medium

$\mu_L$  is less  $\Rightarrow$   $v_L$  is more  $\Rightarrow$  left Handed  
Optically Active Medium  
or

Leavo Rotating Medium.

$$\left\{ \begin{array}{l} \theta \approx A + \frac{B}{\lambda^2} \\ \text{~~Normal dispersion~~ \end{array} \right\} \therefore \mu \approx \left[ \alpha + \frac{\beta}{\lambda^2} \right]$$

$\theta$  calculated at a particular  $(\lambda, T)$

Specific Rotation for solutions

[Angle of Rotating per unit concentration per unit length]

$$S = \left( \frac{\theta}{C \cdot L} \right)$$

$\theta$ : degrees  
 $C$ : gram/cm<sup>3</sup>  
 $L$ : decimeter

⇒ "specific" means: for unit thing, what is the measurement...

Fresnel Theory of Optical Rotation

[Note that here no concept of e ray or o ray]

✓ Linearly Polarized light can be mathematically expressed as a combination of left rotating Circular Polarized light & right rotating Circular Polarized light.

$$\begin{cases} E_y = E_y^0 \sin(kz - \omega t) \\ E_x = 0 \end{cases}$$

$$E_y = \frac{a}{2} \sin(kz - \omega t) + \frac{a}{2} \sin(kz - \omega t)$$

$$E_x = \frac{a}{2} \cos(kz - \omega t) - \frac{a}{2} \cos(kz - \omega t)$$

$$E_x = E_{x1} + E_{x2} = \frac{a}{2} \cos(kx - \omega t) + \frac{-a}{2} \cos(kx - \omega t)$$

$$E_y = E_{y1} + E_{y2} = \frac{a}{2} \sin(kx - \omega t) + \frac{a}{2} \sin(kx - \omega t)$$



$$\Rightarrow E = \left[ \frac{a}{2} \cos(kx - \omega t) \hat{i} + \frac{a}{2} \sin(kx - \omega t) \hat{j} \right] \text{RCP} \\ + \left[ \frac{a}{2} \cos(kx - \omega t) (-\hat{i}) + \frac{a}{2} \sin(kx - \omega t) \hat{j} \right] \text{LCP}$$

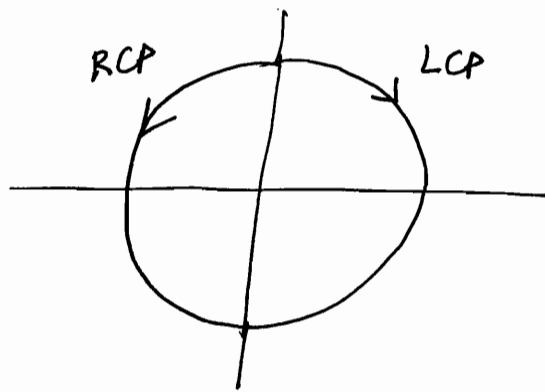

Optical activity नाम  
 ० मापने नाम  
 को Polarimeter  
 बोलते हैं।

Polarizer: produces plane polarized waves from unpolarized light.

Polaroid: a polarizer that has long chains of polymer molecules.

that contain atoms which provide high conductivity along length of the chain.  $\vec{E}$  along that direction is absorbed therefore.

2) Between RCP and LCP, there will be phase difference

$$\Delta = (\mu_y - \mu_x) t$$

$$\phi = \frac{2\pi}{\lambda} (\mu_y - \mu_x) t$$

3) When the light comes out, plane of polarization is rotated.

$$E_x = E_{x_1} + E_{x_2}$$

$$= \frac{a}{2} \left[ \cos(kx - \omega t) + \cos(kz - \omega t + \phi) \right]$$

$$= + a \sin\left(kz - \omega t + \frac{\phi}{2}\right) \sin\left(\frac{\phi}{2}\right)$$

$$= + a \sin\left(\frac{\phi}{2}\right) \sin\left(kz - \omega t + \frac{\phi}{2}\right)$$

$$E_y = E_{y_1} + E_{y_2}$$

$$= \frac{a}{2} \left[ \sin(kx - \omega t) + \sin(kx - \omega t + \phi) \right]$$

$$= a \sin\left(kx - \omega t + \frac{\phi}{2}\right) \cos\left(\frac{\phi}{2}\right)$$

$$= a \cos\left(\frac{\phi}{2}\right) \sin\left(kx - \omega t + \frac{\phi}{2}\right)$$

⇒ Plane rotated by  $\left(\frac{\phi}{2}\right)$

Linearly Polarized light is the outcome.

Optical Rotation  $\theta = \underline{\underline{\left(\frac{\phi}{2}\right)}}$

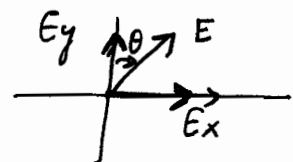

$$\left(\frac{E_x}{a \sin\left(\frac{\phi}{2}\right)}\right) \cdot \left(\frac{E_y}{a \cos\left(\frac{\phi}{2}\right)}\right) \Rightarrow E_y = \frac{E_x}{\tan\left(\frac{\phi}{2}\right)}$$

✓ ⇒ Rotated by  $\theta$  to right

(\*) While the velocity of ordinary ray is same in all directions (circle), velocity of extra-ordinary ray is different in different directions (ellipse). Along a particular direction (fixed in the crystal), the two velocities are equal; this direction is known as optic axis of the crystal.

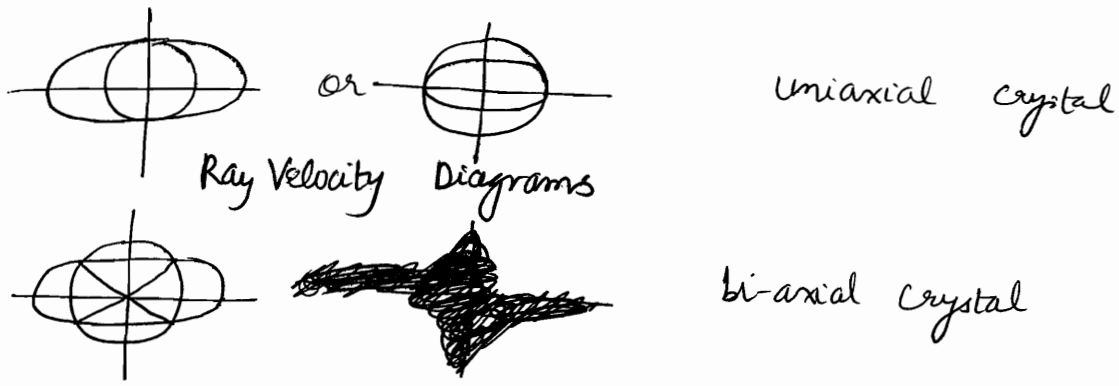

(\*)  $E_x = a \cos(\omega t)$   
 $E_y = b \cos(\omega t + \phi)$  [Superposition of different x and y components give different Lassajoles figures.]

If  $\phi = n\pi \Rightarrow$  linearly polarized

$\phi = -\frac{\pi}{2} \Rightarrow E_x = a \cos \omega t$  if  $a=b \Rightarrow$  RCP  
 $E_y = b \sin(\omega t)$

$\phi = \frac{\pi}{2} \Rightarrow E_x = a \cos \omega t$  if  $a=b \Rightarrow$  LCP  
 $E_y = -b \sin \omega t$

(\*) What we did in QWP and HWP analysis?

✓ let the optic axis in y direction. & let us take a linearly polarized light.

✓ If incident beam is x-polarized, the beam will propagate as an ordinary wave.

✓ If the beam is y polarized, it will propagate as extraordinary wave.

✓ For any other state of polarization, both o and e waves will be present.  
 x component: ordinary beam  
 y component: extraordinary beam

since  $n_o \neq n_e$ , when they come out of crystal, they will not be in the same phase

✓ Now crystals are designed in such a way to introduce desired phase difference

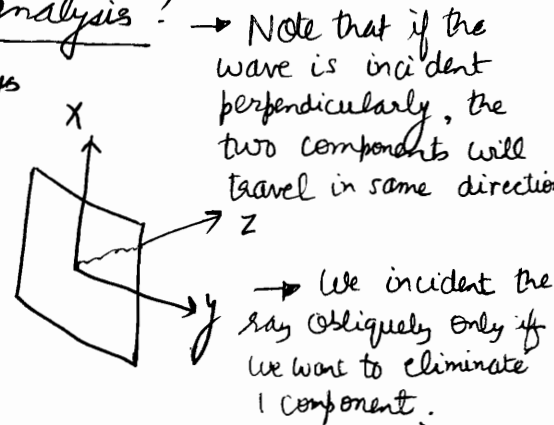

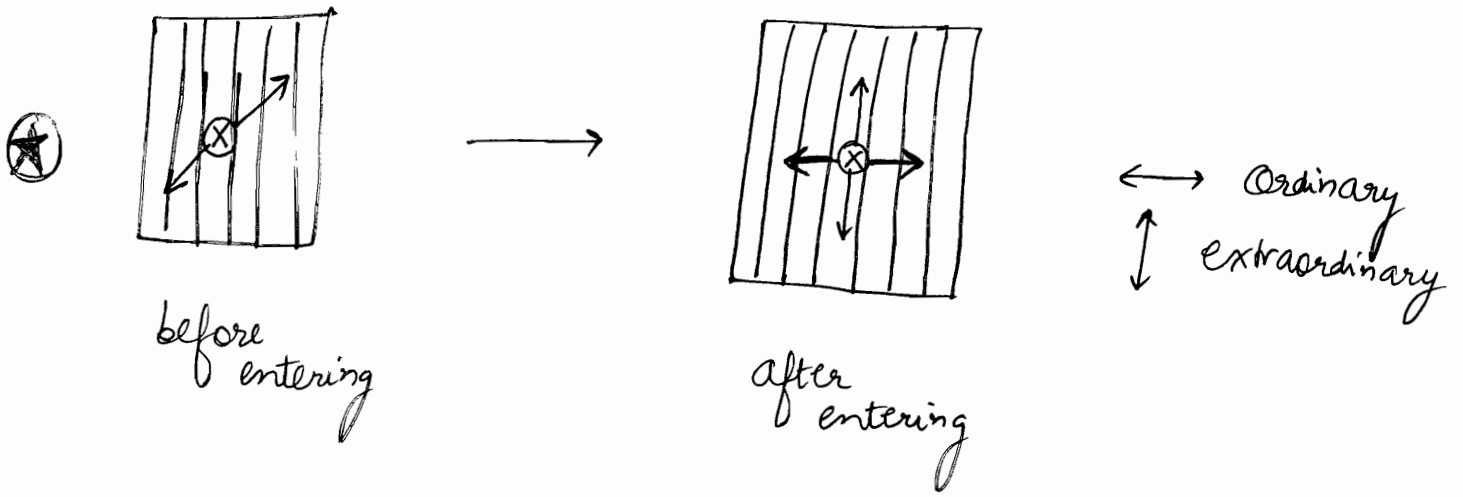

due to this property Nicol Prism can act as Polaroid b'coz it eliminates ordinary ray by TIR. If rotated, along 2 ~~positions~~, we will have polarization  $\perp$  to optical axis, hence ray will pass as Ordinary wave which will get eliminated by TIR. Hence at position intensity will be 0 (zero).

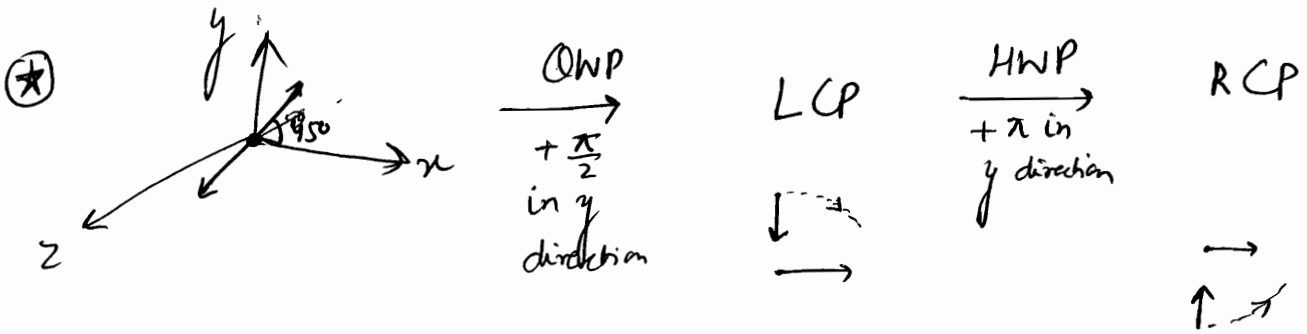

Note that  $E_x$  and  $E_y$  represents components of polarization and not direction of velocity of  $e$  and  $o$  in  $\perp$  direction.  $\Delta\phi_y = (n_e - n_o)t$

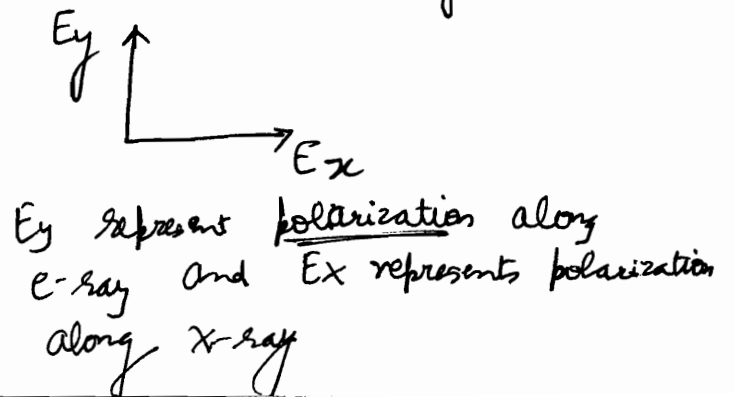
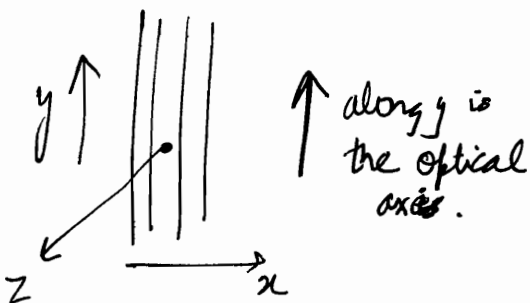



LASER

Light Amplification by Stimulated Emission of Radiation

eg.

Solid State Laser

eg. Ruby Laser

Gas Laser

eg. ~~He-Ne~~ He-Ne Laser

Semi Conductor Laser

Chemical (Dye) Laser

Characteristics of Laser

- 1) Highly Coherent
- 2) High degree of monochromaticity ( $\Delta\lambda$  is very small)
- 3) High Intensity (Power per unit area is high)
- 4) Unidirectional i.e. highly focussed (diffraction limited)
- 5) Polarized Beam

✓ (1), (2), (4), (5) are a result of Stimulated Emission (S.E.)

✓ (3) is due to Population Inversion ~~of the atoms~~

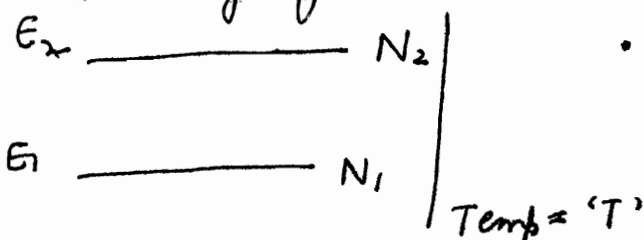
Working of Lasers

• 2 levels of energy of any atom's electrons are discrete.

$$N_2 = N_1 e^{-(E_2 - E_1)/kT}$$

$$e^{x} = y$$

$$\text{if } x > 0 \Rightarrow y > 1$$

$$x < 0 \Rightarrow y < 1 \quad [\text{Maxwell-Boltzmann}]$$

at normal Temp.  
i.e.  $N_2 < N_1$

i.e. more population  
in ground state

$$E_2 - E_1 = h\nu$$

$$N_2 = N_1 e^{-\frac{h\nu}{kT}}$$

If somehow I am able to make  $N_2 > N_1$ , then we achieve Population Inversion. Such a state is called 'Negative Temperature' state, thermodynamically.

Energy density of E.M. radiation (is given by Planck's Formula) of frequency  $\nu$  and temperature  $T$ .

$$u(\nu) d\nu = \frac{8\pi h \nu^3}{c^3} \frac{d\nu}{(e^{h\nu/kT} - 1)}$$

Energy per unit volume

$$\Rightarrow u(\nu) = \frac{8\pi h \nu^3}{c^3 (e^{h\nu/kT} - 1)}$$

$$u(\nu) d\nu = \frac{8\pi V \cdot \nu^2 d\nu}{c^3} \frac{h\nu}{(e^{h\nu/kT} - 1)}$$

$$\Rightarrow u(\nu) = \frac{8\pi h \nu^3}{c^3 (e^{h\nu/kT} - 1)}$$

$\Rightarrow E_2$  to  $E_1$  jump can be either stimulated or spontaneous.

$\Rightarrow$  { Mechanical, Heat } Methods to reach higher level.  
{ Current, Optical }

These are called Pumping Mechanism or Excitational Mechanism.

[limit of  $\Delta E \Delta t$  defined by Heisenberg]

Hence, they have to come down.

(1)

$\Downarrow$   
with their help  
Population  
Inversion is achieved

For spontaneous jump, no agent is required.

In stimulated jump, external agent photon is required  
Along photon it comes ~~out~~ down.

4 characteristics are achieved.

(2) Stimulated emission achieved.  
Upon the [ACTIVE MEDIUM]

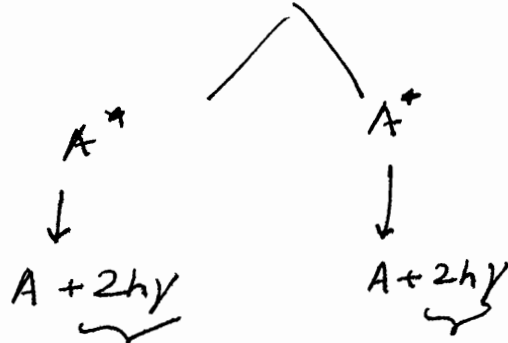
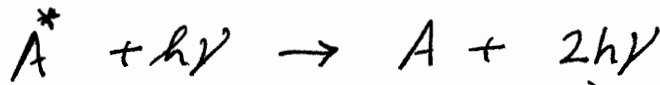

(3) Feedback Mechanism is achieved via  
Resonator Cavity Arrangement

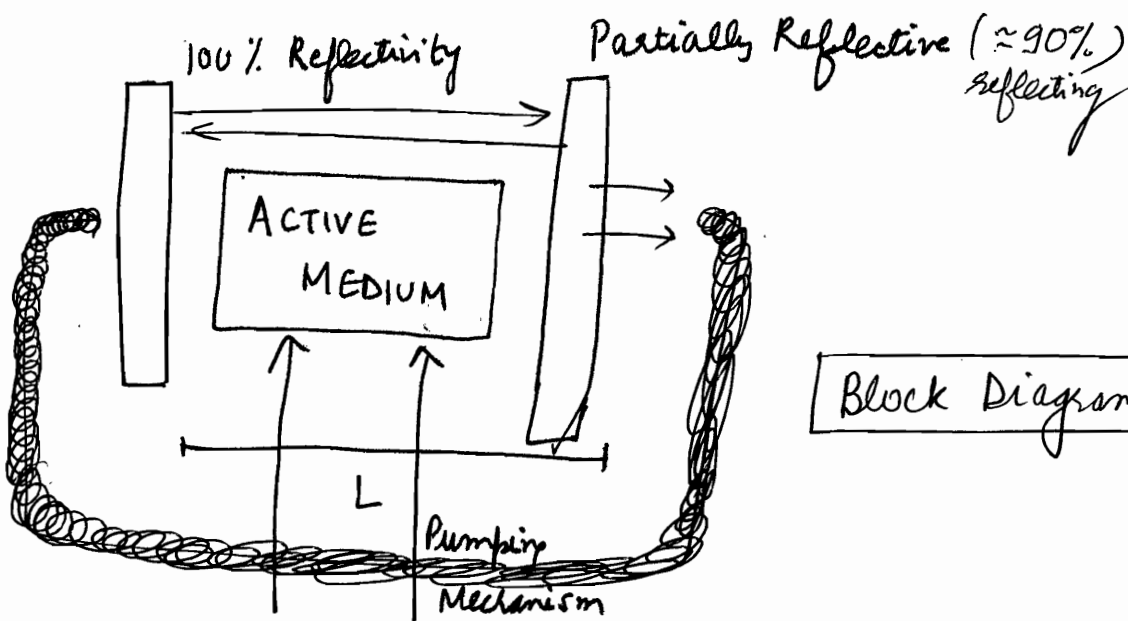

Block Diagram of Laser

$$L = n \frac{\lambda}{2}$$

Lasers are named after Active Medium. eg. Ruby is crystal (solid cylindrical rock)

i.e. Active Medium can be solid, gas, semiconductor, chemical (dye).



Calculations

- Expressed as [per second]
- $A_{21}$ : Probability ~~Coefficient~~ Group for Spontaneous Emission
  - $B_{21}$ : Probability ~~Coefficient~~ for Stimulated Emission
  - $B_{12}$ : Probability <sup>Coefficient</sup> of stimulated absorption

$$\text{Probability} = \left[ \frac{dN}{N dt} \right]$$

i.e. fraction of particles (~~atoms~~) per second.  
 or  
 (falling)  
 or  
 (rising)

$$N_1 B_{12} u(\nu) dt$$

[no. of photons per unit volume of frequency  $\nu$ ]

: No. of atoms raised to higher level via Stimulated Absorption of Photons of energy  $h\nu$  per unit volume per unit time.

Out of them, some of them will come, of their own, down, and some via stimulated emission.

$$N_2 u(\nu) B_{21} + A_{21} N_2$$

⇒

$$N_1 B_{12} u(\nu) = N_2 u(\nu) B_{21} + A_{21} N_2$$

rate of stimulated absorption

Rate of stimulated emission

Rate of spontaneous emission

Einstein's

Thermodynamic Equations

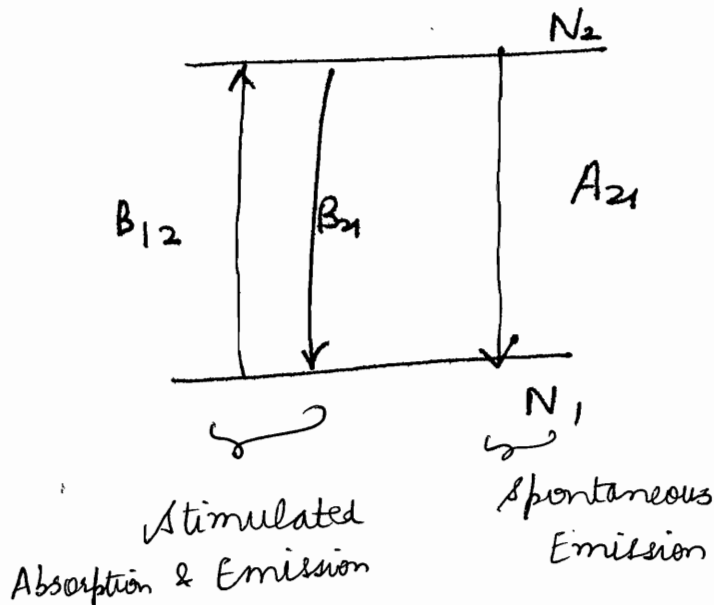

Note that A, B etc. have no significance (Probability is crap)

$$(N_1 B_{12} - N_2 B_{21}) u(\nu) = N_2 A_{21}$$

$$u(\nu) = \frac{N_2 A_{21}}{N_1 B_{12} - N_2 B_{21}}$$

$$= \frac{\left(\frac{A_{21}}{B_{21}}\right)}{\left(\frac{N_1}{N_2}\right) \left(\frac{B_{12}}{B_{21}}\right) - 1} = \frac{\left(\frac{A_{21}}{B_{21}}\right)}{\left(\frac{B_{12}}{B_{21}}\right) e^{\frac{h\nu}{kT}} - 1}$$

From Planck's Formula

$$u(\nu) = \frac{8\pi h \nu^2}{c^3} \frac{1}{e^{h\nu/kT} - 1}$$

Comparing the 2 equations:

$$\Rightarrow \frac{A_{21}}{B_{21}} = \frac{8\pi h \nu^3}{c^3} \Rightarrow \frac{A_{21}}{B_{21}} = \frac{8\pi h \nu^3}{c^3}$$

$$\& \frac{B_{12}}{B_{21}} = 1 \Rightarrow \boxed{B_{12} = B_{21}}$$

Probability of Stimulated Emission = Probability of Stimulated Absorption

$$\boxed{B_{21} = \frac{c^3}{8\pi h \nu^3} A_{21}}$$

Note that  $B_{21} \propto u(\nu)$  is the probability  
 $\Rightarrow$  For a given  $u(\nu)$ ,  $B$  is  $\propto \frac{1}{\nu^3}$

✓ higher the frequency, lower the probability of stimulated emission  $\Rightarrow$  we cannot get Lasers in  $\gamma$  rays or X-rays.

Visible light or lower frequencies can have Lasers.  
eg. for Microwave: MASER

Examples

Since  $B_{12} = B_{21} \Rightarrow$  2 level laser cannot be achieved

Ruby Laser

660 nm

$10^{-8}$  sec

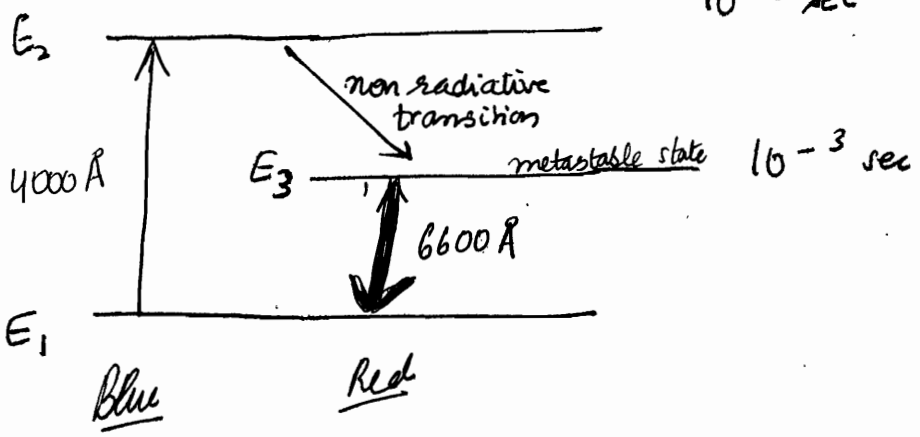

Ruby Laser

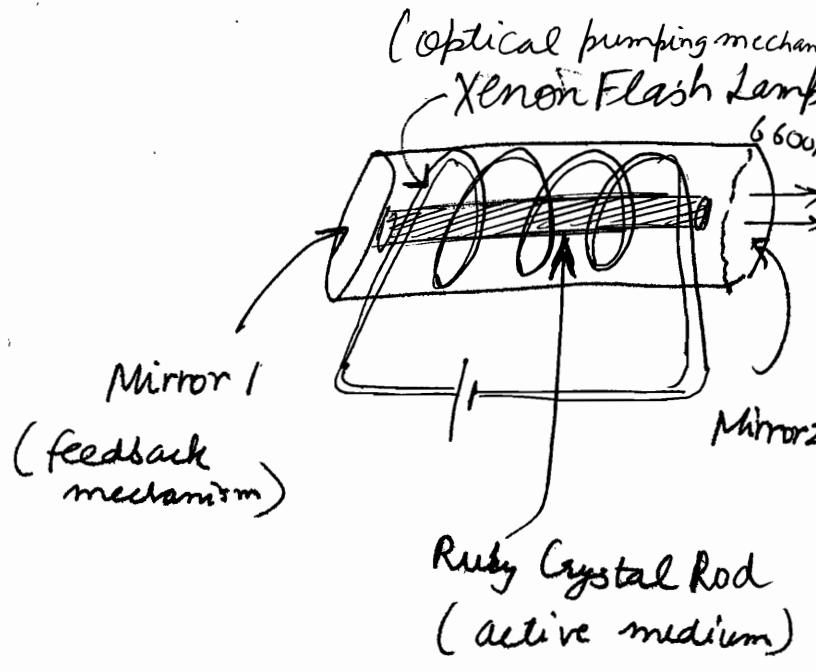

$E_1$  to  $E_3$  level via absorption of blue light ( $4000 \text{ \AA}$ ). Some of the excited atoms come to  $E_3$  state. Note that no population accumulation at  $E_2$  since  $\Delta t = 10^{-8}$  sec. There will be some population accumulation at  $E_3$  level. 1 photon will cause  $(E_3 - E_1)$  transition and this stimulated emission will produce 2 photons and the mechanism continues.

He-Ne Laser

633 nm

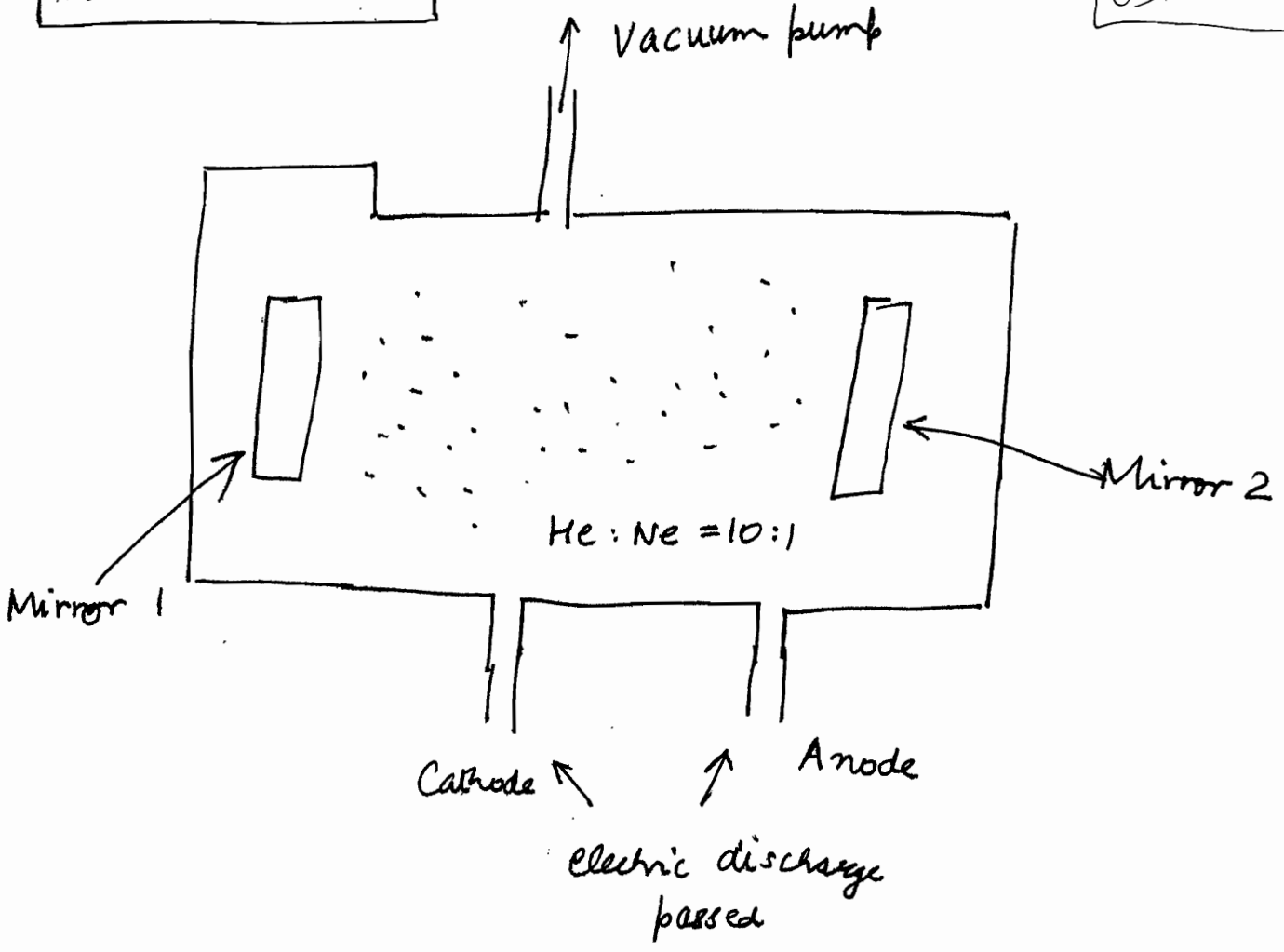

Here excitation mechanism is atomic collisions

Output : 6328 Å

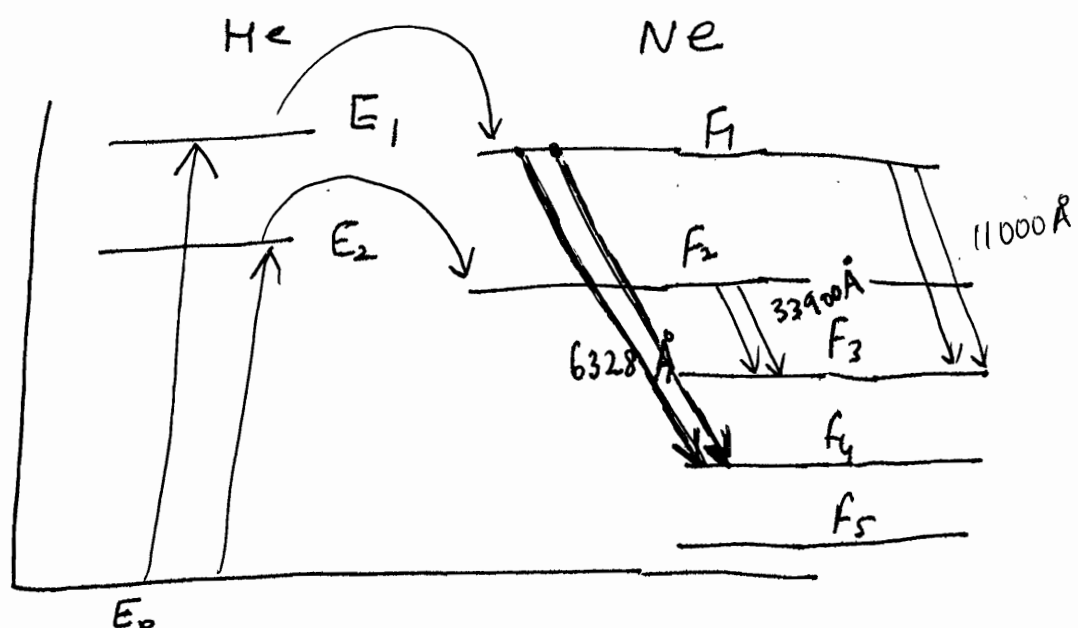

Characteristics of He-Ne



(electric discharge)

$e^-$  collide with He and Ne atoms. Energy of He atoms is thereby raised. When He collides with Neon, it transfers energy and raises Ne atoms to high energy levels (not easily achieved). [Note that by  $e^-$  collisions  $F_4$  or  $F_5$  is achieved but from He collision  $F_1$  or  $F_2$  is achieved]

Population Inversion b/w  $F_1$  and  $F_4$  is achieved, thereby resulting in continued Stimulated Emission.

By selecting reflectivity of mirrors, other modes can be suppressed. Hence only  $6328 \text{ \AA}$  is produced.

Tut 13  
last Q

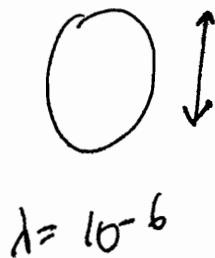

$$\text{Power} = 3 \text{ MW}$$

$$d = 10 \text{ mm}$$

$$f = 50 \text{ mm}$$

Assume Circular Aperture :  $I = \frac{0.84 P}{\text{Area spread}}$

$$y_1 = \left( \frac{f d}{d} \right)$$

$$= \frac{0.84 \times 3 \times 10^6}{\pi y_1^2}$$

$$I = \frac{1}{2} \epsilon_0 c E_0^2 \Rightarrow E_0 = \sqrt{\frac{2I}{\epsilon_0 c}}$$

⊛ a 2mW diffraction limited laser beam incident on the eye can produce an intensity of about  $10^6 \text{ W/m}^2$  at the retina: this would certainly damage the retina. Thus, whereas it is quite safe to look at a 500 W bulb, it's very dangerous to look directly into a 5mW laser beam. Indeed, because laser can be focussed to very narrow areas, it has found applications in fields like eye surgery, laser cutting.

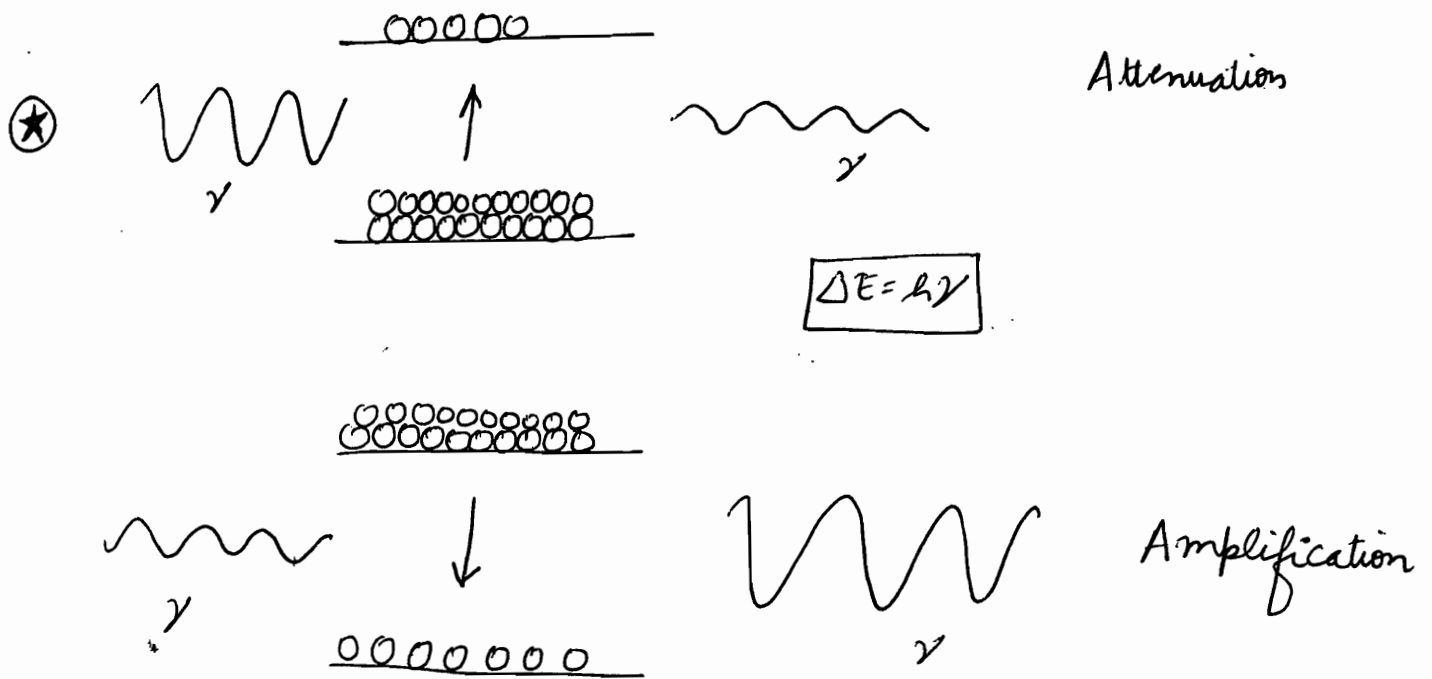

The light amplification process due to stimulated emission is phase coherent i.e. energy delivered by the molecular system has same phase & frequency as stimulating radiation. Population inversion is essential for light amplification. Conversely if population of lower level is more, no. of stimulated emissions will be less than no. of stimulated absorption, resulting in attenuation of signal beam.

### ⊛ Modes of Laser

$$n \frac{\lambda_n}{2} = L$$

$$\Rightarrow \nu_n = \frac{n(c/\lambda)}{2L}$$

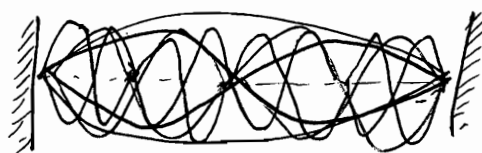

(similar to Fabry-Perot)

The sides of the resonator cavity are open and all modes have finite loss due to diffraction spillover at the mirrors edges. In addition, there are other losses like scattering, absorption etc. Modes that keep on oscillating are those for which gain provided by laser medium compensates for losses. Since gain provided by medium depends on extent of population inversion, for each mode there is critical value of population inversion (called threshold popl<sup>n</sup> inversion) below which that particular modes cease to oscillate.

- ⊛ Ruby consists of  $Al_2O_3$  with some of the Aluminium atoms replaced by Chromium.
- ⊛ For triggering the LASER action, a spontaneously emitted photon is sufficient.

### ⊛ Advantage of Gas Lasers

- ① More directional & monochromatic light
  - ② Absence of defects like crystal imperfections thermal distortions and scattering, that are present in solid-state lasers.
  - ③ Gas lasers are capable of operating continuously w/o need for cooling.
- ⊛ Resonator Cavity is same as Fabry-Perot Etalon, difference between them is spacing in laser is large as compared to Fabry Perot interferometer spacing

# Einstein Coefficients

An atom in the lower energy level can absorb radiation and get excited to level  $E_2$ . This excitation process (whether stimulated or spontaneous) can occur only in the presence of radiation. The rate of absorption depends on density of radiation at particular frequency corresponding to  $\Delta E$ . Energy density  $u(\nu)$  is defined such that

$$u(\nu) d\nu = \text{radiation energy per unit volume within frequency interval } \nu \text{ and } \nu + d\nu$$

The rate of absorption is proportional to  $N_1$  and also to  $u(\nu)$

$$\therefore \text{No. of absorptions per unit volume per unit time} = \underbrace{N_1 B_{12} u(\nu)}_{\substack{\text{Prob} \\ \text{rate}}}$$

where  $B_{12}$  is coefficient of proportionality and has appropriate dimensions.

In spontaneous emission, probability per unit time of the atom making a downward transition is independent of energy density and depends only upon no. of atoms  $N_2$  in energy state  $E_2$

$$\frac{dN_2}{dt} = - \underbrace{A_{21} N_2}_{\substack{\text{Prob} \\ \text{rate}}}$$

Similarly in stimulated emission,

$$\text{No. of stimulated emissions per unit time per unit volume} = \underbrace{B_{21} N_2 u(\nu)}_{\substack{\text{Prob} \\ \text{rate}}}$$

At thermal equilibrium, number of upward transition must be equal to number of downward transitions.

$$N_1 B_{12} u(\nu) = N_2 B_{21} u(\nu) + A_{21} N_2$$

$$\Rightarrow u(\nu) = \frac{A_{21}}{\frac{N_1}{N_2} B_{12} - B_{21}} = \frac{(A_{21}/B_{21})}{\left(\frac{B_{12}}{B_{21}}\right) \left(\frac{N_1}{N_2}\right) - 1}$$

At thermal equilibrium ratio of number of spontaneous to stimulated emissions is given by

$$\frac{A_{21} N_2}{B_{21} N_2 u(\nu)} = \frac{A_{21}}{B_{21} u(\nu)} = e^{\left(\frac{h\nu}{kT}\right)} - 1$$

at  $T=10^3 \text{ K}$ ,  $\omega=3 \times 10^{15} \text{ sec}^{-1}$ ,  $\lambda=6000 \text{ \AA}$ , ratio  $\approx 10^{10}$   
 $\Rightarrow$  When atoms are in thermal equilibrium, emission is predominantly spontaneous and hence emission from ordinary light source is incoherent.

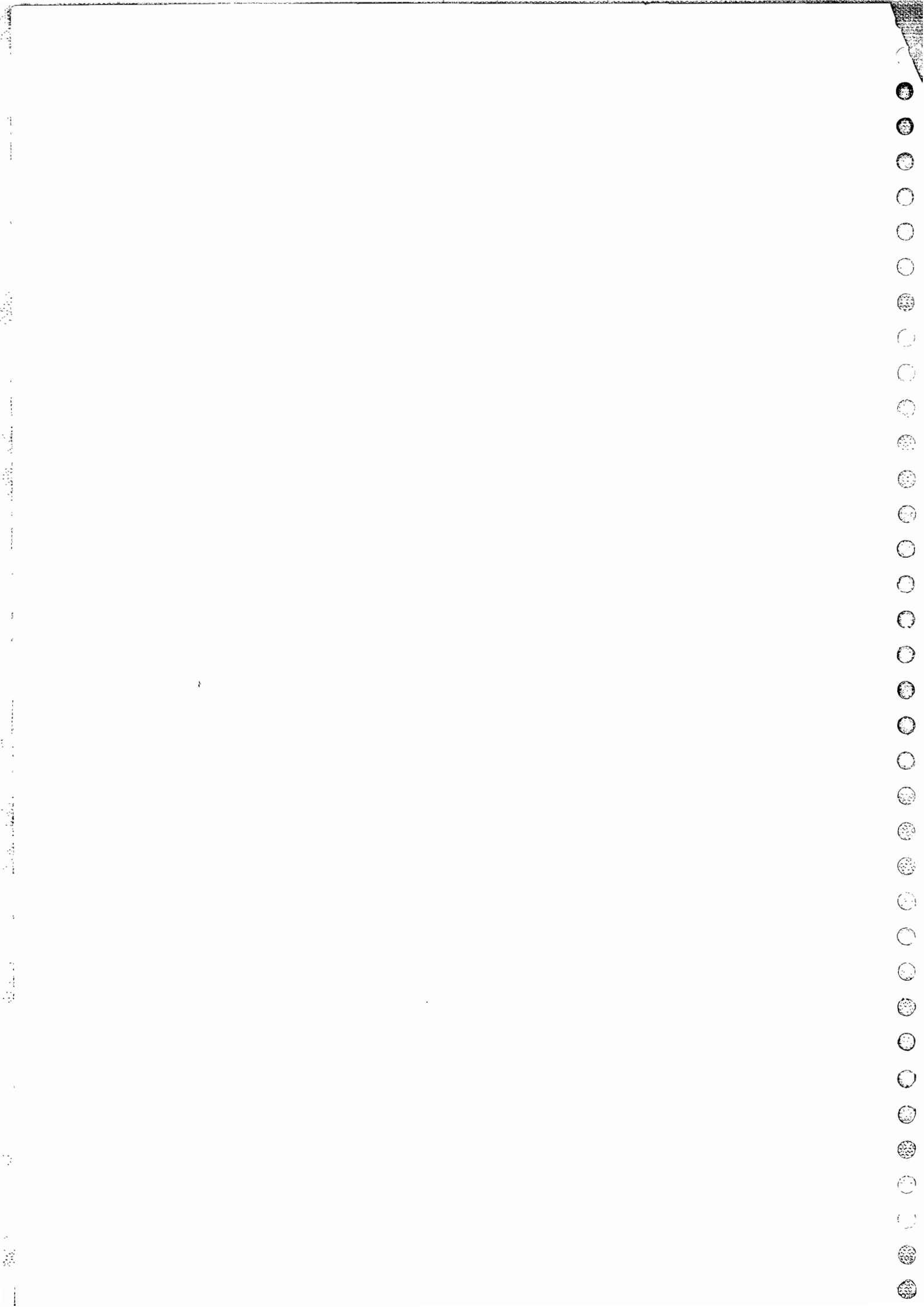

# OPTICS (18)

## OPTICAL FIBRES

Def<sup>n</sup>: "Hair thin strands of glass used as a transmission media to carry information signals in the form of optical pulses based on principle of Total Internal Reflection"

Typical Cross section

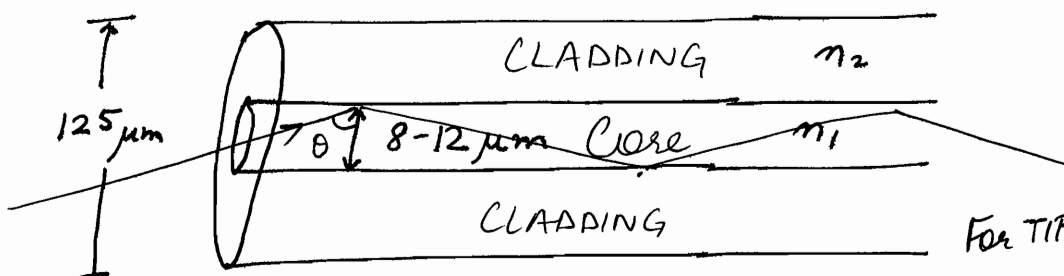

For TIR,  $\theta > \theta_c$

$$\sin \theta > \sin \theta_c$$

$$\sin \theta > \left( \frac{n_2}{n_1} \right)$$

$$n_{\text{core}} > n_{\text{cladding}}$$

$$n_1 > n_2$$

TIR @ Core - Cladding Interface, throughout the length of fibre.

Typically  $n_1 = 1.48$

$$n_2 = 1.46$$

Very small difference. Made via fine doping during glass formation stage.

$$\theta_c = 80.56^\circ$$

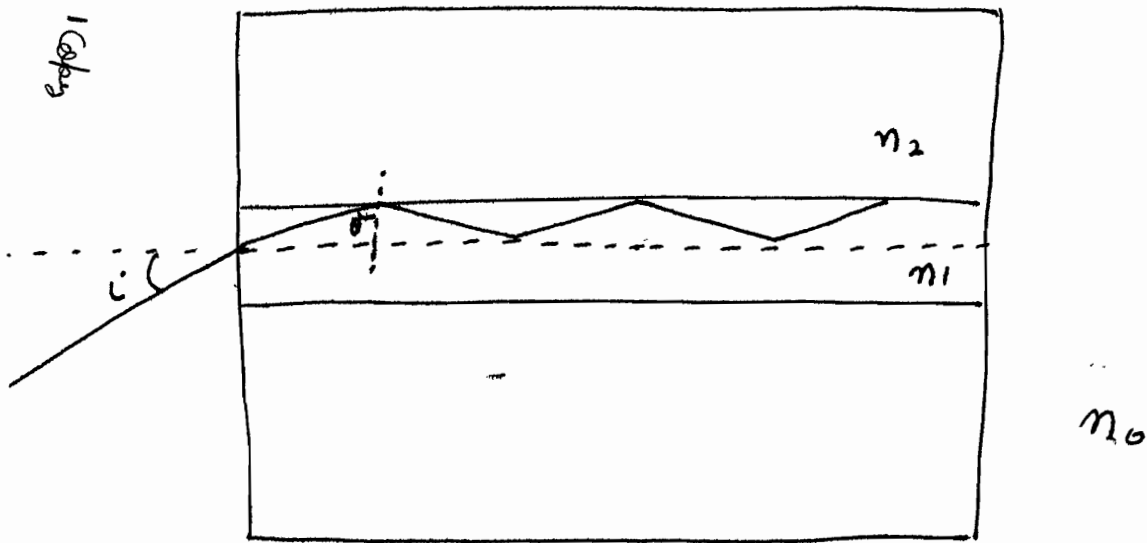

$$n_0 \sin i = n_1 \sin(90^\circ - \theta)$$

$$\Rightarrow \sin i = \left(\frac{n_1}{n_0}\right) \cos \theta$$

$$\Rightarrow \boxed{\cos \theta = \left(\frac{n_0}{n_1}\right) \sin i}$$

For TIR,  $\sin \theta > \left(\frac{n_2}{n_1}\right) \Rightarrow \sin^2 \theta > \left(\frac{n_2}{n_1}\right)^2 \Rightarrow -\sin^2 \theta < -\left(\frac{n_2}{n_1}\right)^2$

$$\Rightarrow 1 - \sin^2 \theta < 1 - \left(\frac{n_2}{n_1}\right)^2 \Rightarrow \cos \theta < \sqrt{1 - \left(\frac{n_2}{n_1}\right)^2}$$

$$\Rightarrow \left(\frac{n_0}{n_1}\right) \sin i < \sqrt{1 - \frac{n_2^2}{n_1^2}}$$

$$\Rightarrow \boxed{\sin i < \frac{\sqrt{n_1^2 - n_2^2}}{n_0}}$$

$$\Rightarrow \boxed{\sin i < \sqrt{n_1^2 - n_2^2}}$$

$$n_0 = 1$$

Define:  $\sin i_m = \sqrt{n_1^2 - n_2^2}$   
 $i_m = \sin^{-1}(\sqrt{n_1^2 - n_2^2})$

$i_m$ :  $i_{\text{maximum}}$



$$\Rightarrow i < i_m$$

Numerical Aperture of Fiber =  $\sqrt{n_1^2 - n_2^2}$

Also called 'Light Gathering Power of the Fiber'

$$\sqrt{(1.48)^2 - (1.46)^2} = 0.24$$

Numerical Aperture for a typical fibre

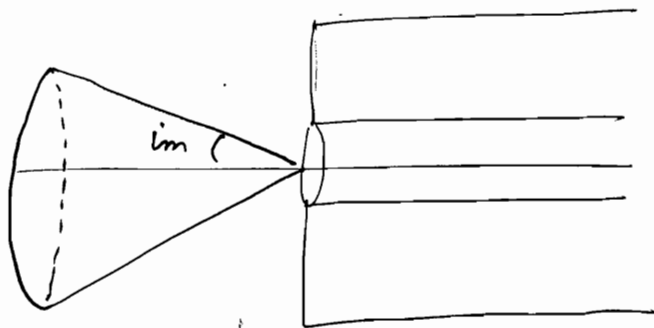

→ In Order to gather more light, we do not increase the numerical aperture, because it increases pulse dispersion

$$i_m = \sin^{-1}(0.24) = 14^\circ$$

$\Rightarrow$  for  $\forall i < 14^\circ$ , the light pulses will be optically guided inside the fiber and will reach the other end.

### Attenuation

Attenuation is the loss of power.

### Modes

Modes = Paths

There can be multiple modes inside the fiber.

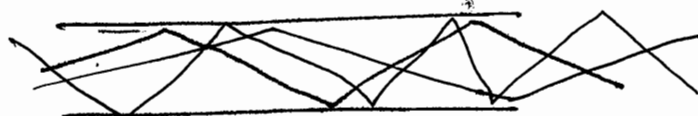

○  $i=0, \theta=90^\circ$ : 1 mode

Only if this mode is allowed  $\Rightarrow$  Single Mode Optical Fiber

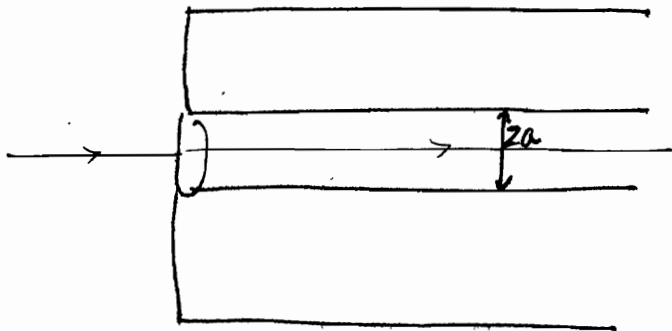

$\rightarrow$  Done by Special design

ie.  $\frac{2\pi}{\lambda} a \sqrt{n_1^2 - n_2^2} \leq 2.4$

Single Mode Fiber

No. of modes that can travel in a step-index fiber =  $\left(\frac{V^2}{2}\right)$

For cylindrical fibre:  $\left(\frac{4V^2}{\lambda^2}\right)$

○ Normal Optical fibre is Multi Mode Fiber

$i < i_m$

Nothing special.

"V No. of Fibre"

$\Leftrightarrow$   $\alpha$  of diffraction

$$\frac{\pi d \sin \theta}{\lambda}$$

$d$ : diameter  
 $\theta$ :  $\theta_{in}$

ie.  $\alpha \leq 2.4$

Multi Mode Fiber

$\lambda_0$  = cut off wavelength

$$\lambda \geq \lambda_0 = \frac{2\pi a \sqrt{n_1^2 - n_2^2}}{2.4}$$

for single mode operation

### STEP INDEX FIBRE

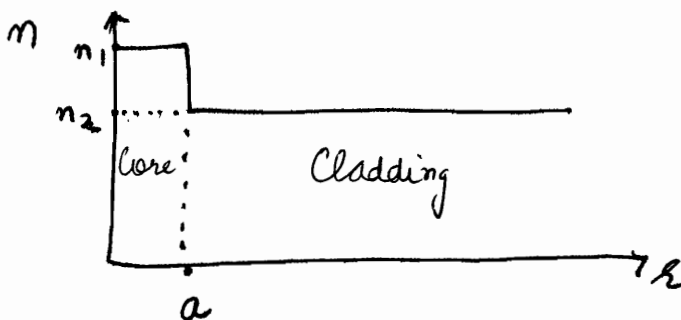

$n_1$ : const.

$n_2$ : const.

$n_1 > n_2$

### GRADED INDEX FIBRE

Refractive index is graded

$n_1 > n_2$  always

$$n(r) = n_1 \left[ 1 - \left(\frac{r}{a}\right)^2 \right] \quad r < a$$

$$= n_2 \quad r > a$$

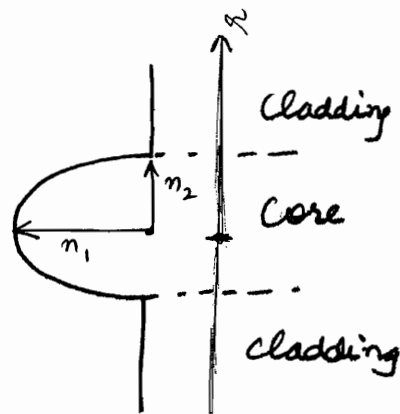

$$@ r = a$$

$$n_1 \left[ 1 - \left( \frac{a}{r} \right)^2 \right] = n_2$$

Refractive Index of core is variable. Refractive Index of cladding is const.

Named after name of conic section:

Parabolic Graded Fibre

Circularly Graded Fibre.

## Defects

(1) Attenuation

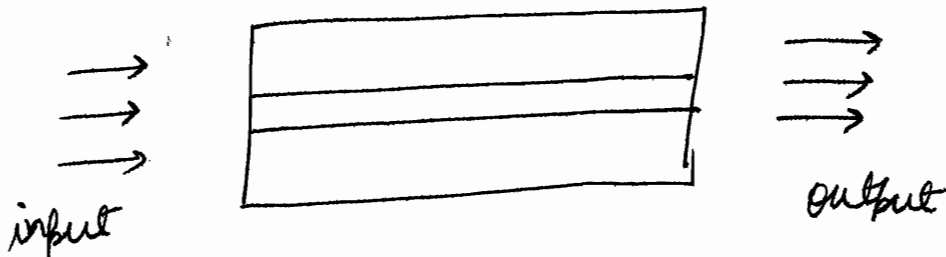

$$\text{Attenuation (in db)} = 10 \log_{10} \left( \frac{P_{\text{output}}}{P_{\text{input}}} \right) \text{ db}$$

If  $\text{output} > \text{input} \Rightarrow \text{GAIN}$   
If  $\text{input} > \text{output} \Rightarrow \text{LOSS}$

If  $P_{\text{output}} = 2 P_{\text{input}} \Rightarrow 3 \text{ db gain}$   
If  $P_{\text{output}} = \frac{1}{2} P_{\text{input}} \Rightarrow 3 \text{ db loss}$

$$(\log 2 = 0.3)$$

Attenuation is measured per unit length. (Called Attenuation constant)

Fiber is extremely low-loss medium.

(2) Dispersion  $\left(\frac{\Delta c}{L}\right)$

Broadening of signal w.r.t. time as it travels down the fiber.

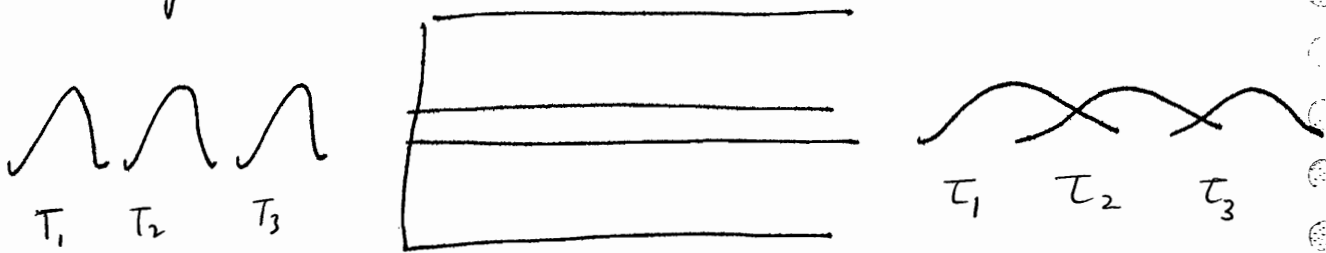

Overlapping of output makes the signal hard to detect, i.e. loss of synchronization !!

→ Dispersion is of 2 types:

1) Pulse Dispersion

Multimode Fiber  $\Rightarrow$  Multiple Paths  $\Rightarrow$  Multiple times to reach the other end  $\Rightarrow$  Broadening of Pulse.

Hence, Single Mode Fibers are preferred.

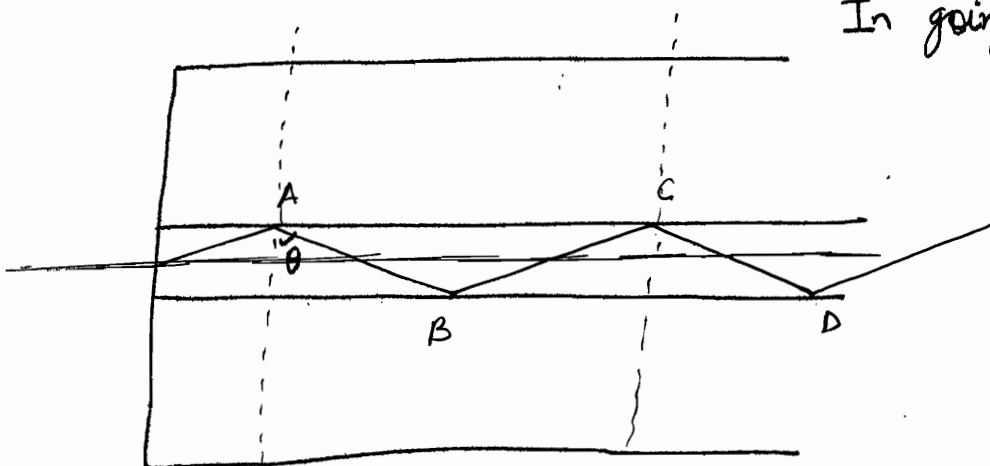

In going from A to C,

$$\Delta t = \frac{AB + BC}{c}$$

$$= \frac{L \cdot n_1}{\sin \theta \cdot c}$$

$$= \left(\frac{n_1 L}{c}\right) \left(\frac{1}{\sin \theta}\right)$$

$$T_{\min} = \left(\frac{n_1 L}{c}\right) \frac{1}{\sin \theta_{\max}} = \left(\frac{n_1 L}{c}\right) \quad [\theta = 90^\circ]$$

$$T_{\max} = \left(\frac{n_1 L}{c}\right) \frac{1}{\sin \theta_{\min}} = \frac{n_1 L}{c} \cdot \left(\frac{n_1}{n_2}\right) \quad [\theta_c]$$

$$T_{\max} = \frac{n_1^2}{n_2} \left(\frac{L}{c}\right)$$

$$\Rightarrow \text{Broadening} = T_{\max} - T_{\min}$$

$$= n_1 \frac{L}{c} \left[ \frac{n_1}{n_2} - 1 \right]$$

$$= \left(\frac{n_1 - n_2}{n_2}\right) \left(\frac{n_1 L}{c}\right) = \left(\frac{n_1}{n_2}\right) \left(\frac{L}{c}\right) (n_1 - n_2)$$

$$\text{Pulse dispersion per unit length} = \left(\frac{n_1}{n_2}\right) \left(\frac{1}{c}\right) (n_1 - n_2)$$

$$\left(\frac{\Delta T}{L}\right)$$

$$\approx 50 \text{ nsec / km}$$

$$(2) \text{ Material Dispersion} \quad \left(\frac{\Delta T}{L \cdot \Delta \lambda}\right)$$

due to spectral width of light source.

Present even in single mode fiber.

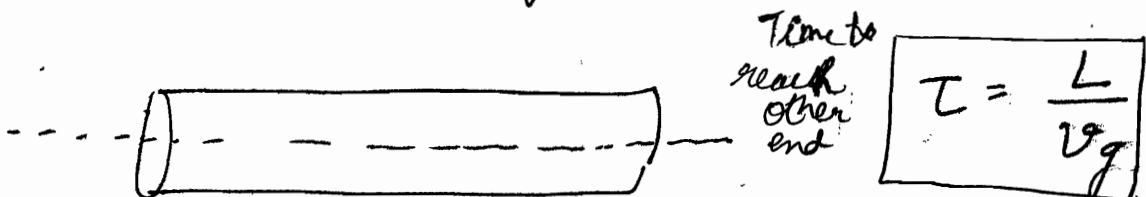

$$\text{Material dispersion} = \left(\frac{\Delta T}{L}\right)$$

We know,

$$v_g = v_p \left( 1 + \frac{\lambda}{n} \frac{dn}{d\lambda} \right)$$

$$= \left( \frac{c}{n} \right) \left[ 1 + \frac{\lambda}{n} \left( \frac{dn}{d\lambda} \right) \right]$$

$$\frac{1}{v_g} = \left( \frac{n}{c} \right) \left[ 1 + \frac{\lambda}{n} \left( \frac{dn}{d\lambda} \right) \right]^{-1}$$

$$= \left( \frac{n}{c} \right) \left[ 1 - \frac{\lambda}{n} \left( \frac{dn}{d\lambda} \right) \right]$$

$$\Delta \tau_f^2 = \Delta \tau_i^2 + \Delta \tau_{\text{dispersion}}^2$$

$\Delta \tau_i$ : initial pulse width  
 $\Delta \tau_f$ : final pulse width  
 $\Delta \tau_{\text{dis}}$ : dispersion

$$\tau = \frac{Ln}{c} \left[ 1 - \frac{\lambda}{n} \left( \frac{dn}{d\lambda} \right) \right]$$

→ यहाँ तक तो time निकाला है, अब difference of time निकालेंगे !!

⊛ LEDs or LASER : source of optical pulses  
Both have finite, though small, spectral width.

[ 2 nano sec / km : Material dispersion  
Hence can be neglected.... ]

$$\frac{d\tau}{d\lambda} = \frac{L}{c} \left( \frac{dn}{d\lambda} \right) - \frac{L}{c} \frac{d}{d\lambda} \left[ \lambda \left( \frac{dn}{d\lambda} \right) \right]$$

$$= \frac{L}{c} \frac{dn}{d\lambda} - \frac{L}{c} \left( \frac{dn}{d\lambda} \right) - \lambda \frac{L}{c} \left( \frac{d^2n}{d\lambda^2} \right)$$

$$\Rightarrow \frac{d\tau}{d\lambda} = - \frac{\lambda L}{c} \left( \frac{d^2n}{d\lambda^2} \right)$$

$$\Delta \tau = - \frac{\lambda L}{c} \left( \frac{d^2n}{d\lambda^2} \right)$$

$$v_g = \frac{dw}{dk} = \frac{d}{dk} (k v_p) = v_p + k \left( \frac{d v_p}{dk} \right)$$

$$\frac{d\tau}{d\lambda} = -\frac{L}{c} \lambda \left( \frac{d^2 n}{d\lambda^2} \right)$$

### Windows of Fiber

$$\lambda_0 = \underline{850}, \underline{1300}, \underline{1550} \text{ nm}$$

where all losses (including scattering losses, bending losses, doping losses) are minimized.

$M(\lambda)$   
 (\*) Material dispersion coefficient = amount of pulse broadening per unit length of fiber and per unit of spectral width. Usually expressed in picoseconds per (kilometer-nanometer)

$$\Delta\tau = -\frac{\lambda_0 L}{c} \left( \frac{d^2 n}{d\lambda^2} \right) \Big|_{\lambda=\lambda_0} (\Delta\lambda)$$

(\*)  $M(\lambda) \rightarrow 0$  for some wavelengths eg. 1300-1500 nm

(\*) Note that  $M(\lambda)$  is defined for a

$$\Rightarrow \boxed{-\left( \frac{\Delta\tau}{L} \right) = \frac{\lambda_0 (\Delta\lambda)}{c} \left( \frac{d^2 n}{d\lambda^2} \right) \Big|_{\lambda=\lambda_0}}$$

particular central wavelength

Material dispersion per unit length

(\*) Cut off wavelength ( $\lambda_0$ ) = minimum  $\lambda$  at which optical fiber will support single mode

(\*) Above  $\lambda_0$ , only fundamental mode propagates i.e. fiber is Single Mode

$$\lambda_0 = \frac{2\pi a n_1}{V_c} (2\Delta)^{1/2}$$

$V_c$  : normalized frequency

# Advantage of Optical Fibers

(1) Large Bandwidth i.e. very large information carrying capacity.

$10^{18}$  bits (Tera bits) / second can be sent.

(2) Extremely low loss medium  
Repeaters required are less.

(3) Raw material is glass: dielectric medium.  
Hence free from EM disturbance.  
Hence no cross talks, no wastage of energy.

(4) M.P. of glass  $1200^{\circ}\text{C}$ . Hence can be used in chemically hazardous places i.e. safe ~~medium~~ medium.

(5) Secure Medium. We cannot join other fiber just by joining.

(6) Raw Material is abundantly available.

(\*) dispersions are added in squares:  $\Delta L_p^2 + \Delta L_m^2 = \Delta L_{\text{total}}^2$



⊛ It was the discovery of coherent source in form of LASER that triggered the interest in Optical Communication.

⊛ Such a low difference in  $\mu$  of core and cladding is achieved via doping. Cladding is usually pure silica while core is usually silica doped with germanium resulting in increase in refractive index.

⊛ Numerical Aperture,  $NA = \sin i_m = \sqrt{n_1^2 - n_2^2}$

If a cone of light is incident on one end of the fiber, it will be guided through it provided the semi-angle of the cone is less than  $i_m$ . Semi-angle of the cone is measure of, therefore, light gathering power of the fiber and hence defines numerical aperture of the fiber.

⊛ Pulse dispersion is proportional to the square of Numerical Aperture. Thus, to have a smaller dispersion one must have a smaller NA, which of course reduces the acceptance angle and hence light gathering power.

⊛ The Pulse dispersion causes broadening of the pulse, as it propagates through the fiber. Hence, even though two pulses may be well resolved at input end, because of broadening of pulses, they may not be resolvable at output end.

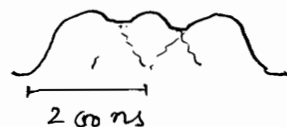
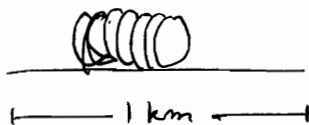
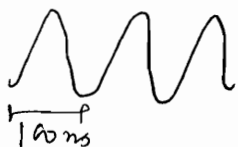

For a parabolic index fiber, pulse dispersion is appreciably reduced. Hence Parabolic index is better.

## Holography

Holography is method in which, unlike a photograph, one not only records the amplitude but also the phase of light wave. This imparts a true 3-d form to the holograph. Therefore, one can change one's position & view a different perspective of the image or one can focus at different distances.

In the recording of the holograph, one superimposes on the object wave, another wave called reference wave and the photographic plate is made to record the resulting interference pattern. Reference wave is usually a plane wave. This recorded interference pattern forms the hologram. It contains information not only about the intensity but also about the phase of object wave.

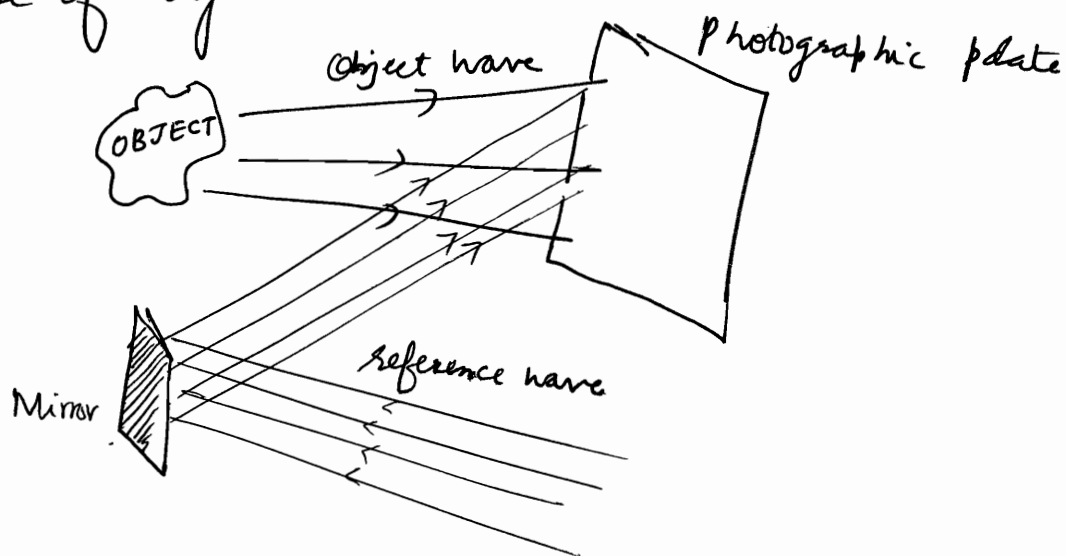

Unlike a photograph, hologram has little resemblance with object. In fact, information about object is coded into the hologram. To view the hologram we

again illuminate the hologram with another wave called reconstruction wave. We can look at virtual image by positioning eye at different angles. The real image can be photographed by placing light sensitive medium at the position where real image is formed.

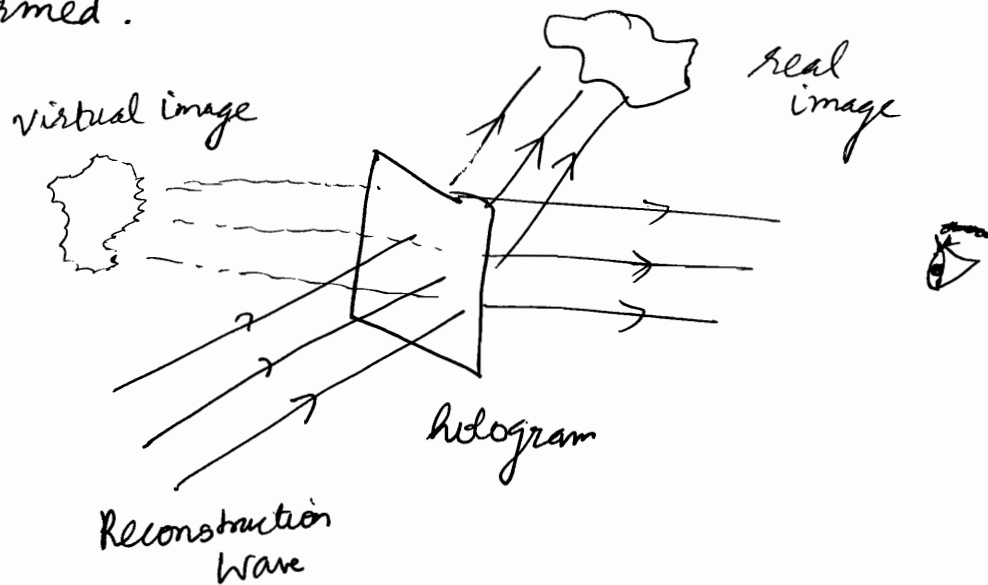

Since holography is an interference phenomenon, coherence requirements have to be met with, i.e. path difference between object wave & reference wave should be less than coherence length.

### Some Applications

- ① Authenticity of valuables
- ② To study transient microscopic events, at leisure by recording their hologram.

# Fraunhofer diffraction in Circular Aperture

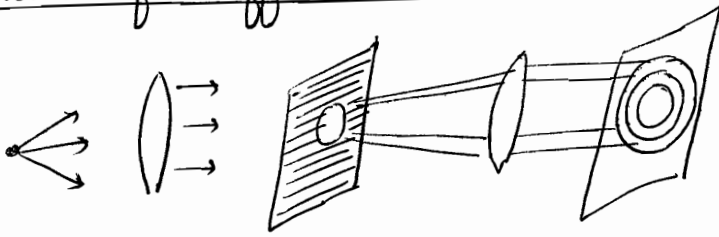

Due to circular symmetry, circular fringes are produced on the screen. The diffraction pattern, so obtained is called Airy Pattern.

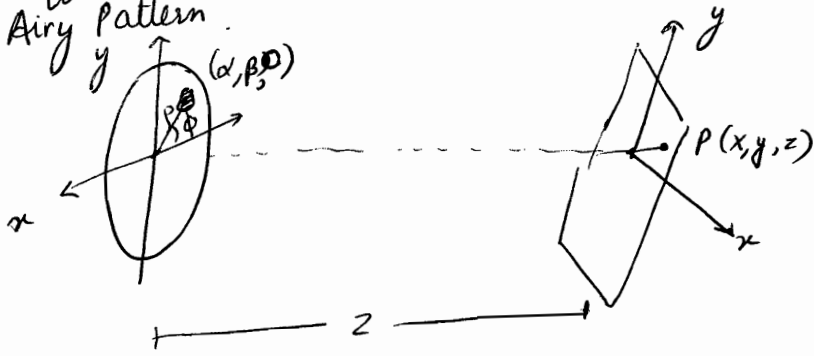

Due to any aperture, amplitude at any point P is given by

$$u(P) = \iint \frac{a e^{i(\vec{k} \cdot \vec{r})}}{(i\lambda) r} d\alpha d\beta$$

$$\text{Now } r = [(x-\alpha)^2 + (y-\beta)^2 + z^2]^{\frac{1}{2}}$$

Ignoring  $\alpha^2, \beta^2$ , we get

$$r = [x^2 + y^2 + z^2 - 2x\alpha - 2y\beta]^{\frac{1}{2}}$$

$$= z \left[ 1 + \frac{x^2 + y^2}{2z^2} - \frac{(x\alpha + y\beta)}{z^2} \right]$$

In denominator, we assume  $r \approx z$ .

$$\Rightarrow u(P) = \iint \frac{a}{i\lambda z} e^{ik(kz + \frac{x^2+y^2}{2z} - \frac{x\alpha+y\beta}{z})} d\alpha d\beta$$

$$= \underbrace{\frac{a e^{ik(z + \frac{x^2+y^2}{2z})}}{i\lambda z}}_{a'} \iint e^{-i(\frac{kx\alpha + ky\beta}{z})} d\alpha d\beta$$

Now, put  $\alpha = \rho \cos \phi$   
 $\beta = \rho \sin \phi$

$$\left(\frac{x}{z}\right) \approx \theta \approx \sin \theta$$

Now pattern on the film will be circular,  $\therefore$  we observe variation along x-axis only.

i.e. take  $y=0$

$$\Rightarrow u(P) = a' \int_0^{a/2} \int_0^{2\pi} e^{-i(k \sin \theta \rho \cos \phi)} \rho d\phi d\rho$$

Put  $k \rho \sin \theta = v$

$$u(P) = a' \int_0^{k a \sin \theta} \int_0^{2\pi} e^{-iv \cos \phi} \frac{dv}{(k \sin \theta)} d\phi$$

$$= \frac{a'}{(k \sin \theta)^2} \left[ \int_0^{k a \sin \theta} v dv \int_0^{2\pi} e^{-iv \cos \phi} d\phi \right]$$

$$= \frac{a'}{(k \sin \theta)^2} v J(v) \Big|_0^{k a \sin \theta}$$

$$= a'' \left[ \frac{J(d_0)}{d_0} \right]$$

where  $d_0 = \frac{\pi d \sin \theta}{\lambda}$

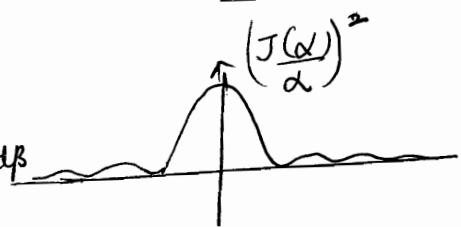

# Holography

✓ 3-d photography.

✓ Normal 2-d Photography is recording of intensity.  
Phase Information is missing.

✓ In holography, Intensity as well as Phase is recorded.

✓ In order to have phase information, we observe interference of 2 waves. We send 2 beams. 1 beam acts as reference beam. (From its reflection we used to make 2-d photos). Now 2<sup>nd</sup> beam is sent and the interference of the 2 reflected waves is recorded. The interference pattern so obtained is the Holograph.

✓ We require Monochromatic & Coherent light.  
conditions for interference...

→ Note that we make 3-d sense out of 2-d photos from a knowledge of shadows, scaling of distant objects etc. Without this knowledge, we may not be able to figure out the 3-dness of the image!!

## Wedge Shaped Film

- (\*) As we can see from adjoining diagram, Photographic Plate P will record straight lines corresponding to P, Q, R, and S. These are positions of maxima as crest of both the reflected waves lie here

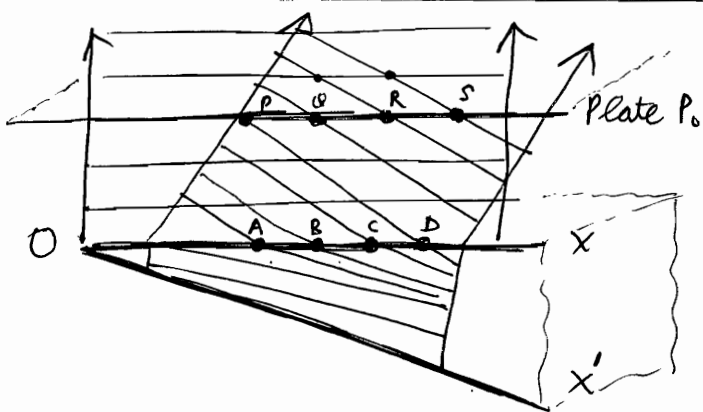

Similarly A, B, C, D are points (or lines  $\parallel$  to edge of the wedge) corresponding to maxima. These lines when viewed by naked eye or focused by camera will appear bright no matter where we keep our eyes or camera. The position of these lines solely depend on  $2\mu t$ .

- (\*) Now for the point A to be bright,

$$\mu(LM + MA) = \left(m + \frac{1}{2}\right) \lambda$$

$$\text{Now } LM + MA \approx 2AA'$$

$$\Rightarrow 2\mu \cdot t_A = \left(m + \frac{1}{2}\right) \lambda$$

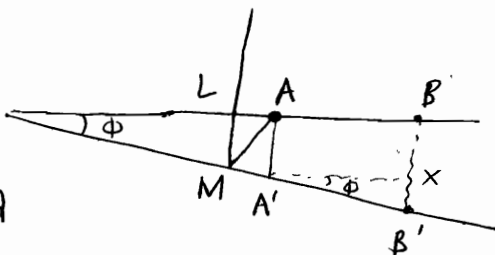

Similarly for B to be bright,  $2\mu t_B = \left(m + \frac{3}{2}\right) \lambda$

$$\Rightarrow XB' = \left(\frac{\lambda}{2\mu}\right) \Rightarrow (A'X) \tan \phi = \frac{\lambda}{2\mu}$$

$$\Rightarrow \boxed{\beta = \frac{\lambda}{2\mu\phi}}$$

- (\*) If we use polychromatic light source, we will observe coloured fringes. Further, if instead of wedge we have a film of arbitrarily varying thickness, we will again observe fringes. This is indeed what we see when sunlight falls on a soap bubble or on a thin film of oil on water.

It should be mentioned that if the optical path difference between the waves reflected from upper surface & lower surface of  $t$

# Diffraction of sound

Obstacles should be small compared to wavelength. For sound waves,  $\lambda$  is large, hence all obstacles are small compared to wavelength, thereby diffraction occurs easily for sound waves all the time, enabling us to hear sounds around the corners.

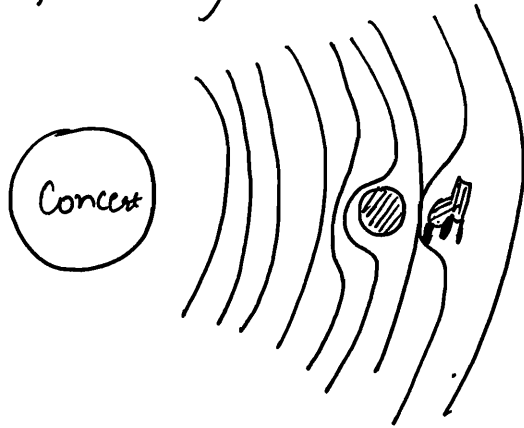

If you are sitting behind pillar, still you can hear concert, as waves of sound bend around the pillar post.

exceeds a few wavelengths (remember the location of central bright fringe in Young's Experiment), the interference pattern will be washed out due to the overlapping of interference patterns of many colours and no fringes will be seen.

## Velocity of waves

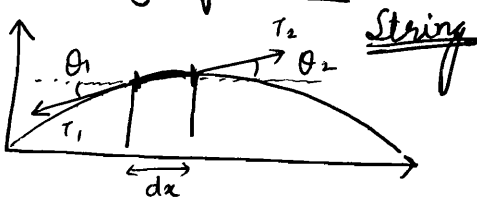

$$\sin\theta \approx \tan\theta = \left(\frac{dy}{dx}\right)$$

Force acting on element  $dx$  in  $y$  direction

$$= T_2 \sin\theta_2 - T_1 \sin\theta_1$$

$$= T \cdot \tan\theta_2 - \tan\theta_1$$

$$= T \cdot \left(\frac{dy}{dx}\right)_{x+dx} - \left(\frac{dy}{dx}\right)_x$$

$$= T \cdot \left(\frac{d^2y}{dx^2}\right) dx$$

$$= \Delta m \left(\frac{d^2y}{dt^2}\right)$$

$$\Rightarrow \left(\frac{\partial^2 y}{\partial x^2}\right) = \frac{\Delta m}{\Delta x T} \left(\frac{\partial^2 y}{\partial t^2}\right)$$

$$\Rightarrow v^2 = \frac{T}{\rho} \Rightarrow v = \sqrt{\frac{T}{\rho}}$$

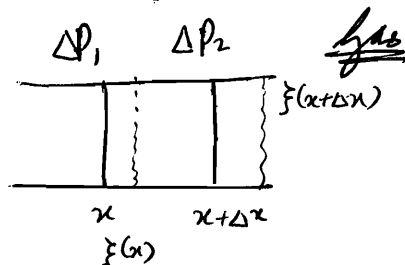

$$\text{Force} = \Delta P_1 A - \Delta P_2 A$$

$$= A \cdot \Delta P_1(x) - \Delta P_2(x+dx)$$

$$= -A \cdot \left(\frac{\partial P}{\partial x}\right) dx \quad \text{--- (1)}$$

$$= \Delta m \cdot \left(\frac{\partial^2 \xi}{\partial t^2}\right)$$

$$= \rho \cdot A \cdot dx \cdot \left(\frac{\partial^2 \xi}{\partial t^2}\right) \quad \text{--- (2)}$$

Now  $PV^r = \text{const}$   
 $\Delta P = -\gamma \frac{P}{V} \Delta V$

and

Change in volume

$$\begin{aligned} \Delta V &= A(\Delta x + \xi(x+\Delta x) - \xi(x)) \\ &\quad - A(\Delta x) \\ &= A \cdot \Delta x \left(\frac{\partial \xi}{\partial x}\right) \end{aligned}$$

$$\Rightarrow \Delta P = -\gamma P \left(\frac{\partial \xi}{\partial x}\right) \quad \text{--- (3)}$$

Using (3) in (1),

$$F = +A \Delta x \cdot \gamma P \left(\frac{\partial^2 \xi}{\partial x^2}\right)$$

$$\Rightarrow \rho \cdot \left(\frac{\partial^2 \xi}{\partial t^2}\right) = \gamma P \left(\frac{\partial^2 \xi}{\partial x^2}\right)$$

$$\Rightarrow v = \sqrt{\frac{\gamma P}{\rho}}$$

# Standing Wave carries no energy

Let us consider a longitudinal standing wave.

$$\xi(x) = 2A \sin \omega t \cos kx$$

Intensity carried by the wave

$$= \frac{\int \vec{F} \cdot \vec{v} \cdot dt}{A \cdot T}$$

$$= \frac{\int P \cdot v \cdot dt}{T}$$

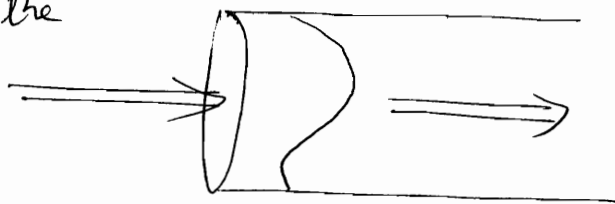

Now we know  $k = - \frac{P}{\left(\frac{dV}{v}\right)} \Rightarrow P = -k \left(\frac{dV}{v}\right)$

To find  $\left(\frac{dV}{v}\right)$ , let us consider a small section of the tube at time  $t$  and  $t + dt$

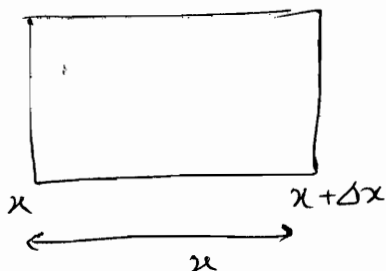

$$V_1 = A \Delta x$$

$$\Rightarrow dV = A [\xi(x + \Delta x) - \xi(x)]$$

$$\Rightarrow \frac{dV}{V} = \frac{dV}{A \Delta x} = \xi'(x)$$

$$\Rightarrow P = -k \cdot \xi'(x) = +k \cdot 2A \sin \omega t \sin kx$$

$$\Rightarrow \text{Intensity carried} = \frac{\int k \cdot 2A \sin \omega t \sin kx \cdot dt}{T}$$

$$= \frac{k \cdot 2A^2 \int \sin^2 \omega t \sin^2 kx \cdot dt}{T} = 0$$



# Directionality of Laser Beams

① An ordinary source of light radiates in all directions. On the other hand, laser beams are diffraction limited only. For most lasers, the transverse amplitude is approximately gaussian

laser beam

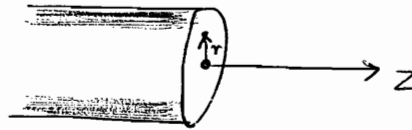

$$A(r) = a e^{-\left(\frac{r^2}{w_0^2}\right)}$$

where  $w_0$  is initial radius of beam, called spot size of the beam

If  $z$  is very large, at a distance  $z$ ,

$$w(z) = \left(\frac{\lambda}{\pi w_0}\right) z$$

ie.  $\theta \approx \left(\frac{\lambda}{\pi w_0}\right)$

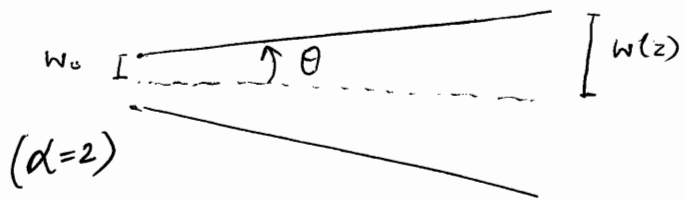

② If laser beam is focussed using a converging lens, then the radius of focussed spot is given by

$$r' = \left(\frac{\lambda_0 f}{a}\right)$$

( $\alpha = 2\pi$ )

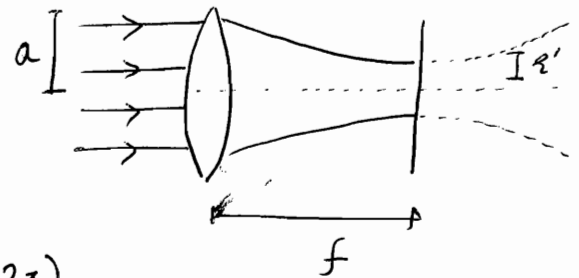

③ Due to diffraction effects

$$\Delta\theta \approx \left(\frac{\lambda}{d}\right)$$

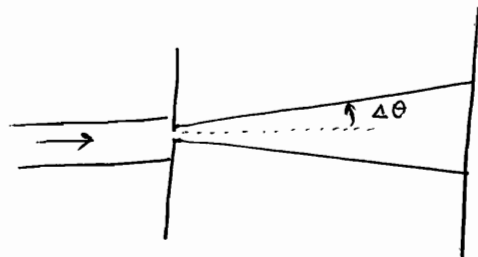

Q1 To prove reflected wave has  $\Delta\phi = \pi$ .

Proceed as in EM

$$y_i = A_i e^{-i(\omega t - k_x x)}$$

$$y_r = A_r e^{-i(\omega t + k_x x)}$$

$$y_t = A_t e^{-i(\omega t - k_x x)}$$

$$y_i + y_r = y_t$$

$$\frac{dy_i}{dx} + \frac{dy_r}{dx} = \frac{dy_t}{dx}$$

$$\Rightarrow \omega_i = \omega_r = \omega_t$$

$$k_i = k_r = k_t \cdot \sqrt{\frac{\rho_1}{\rho_2}}$$

$$\Rightarrow \frac{A_r}{A_i} = \left(\frac{1 - \sqrt{\frac{\rho_2}{\rho_1}}}{1 + \sqrt{\frac{\rho_2}{\rho_1}}}\right)$$

$$\Rightarrow P_t > P_i$$

$$\Rightarrow \underline{A_i = -\alpha A_r}$$

$\Rightarrow$  phase difference of  $\pi$

